

# DELTA VISION

Imaging System  
User's Manual



## Legal Notices

DeltaVision Imaging System User's Manual. PN 29087880 AB

©1999-2014 GE Healthcare. All rights reserved. No part of this manual may be reproduced, transmitted, stored in a retrieval system, or translated into any language in any form by any means without the written permission of GE Healthcare.

Information in this document is subject to change without notice.

DeltaVision, Applied Precision, Nanomotion, and softWoRx are trademarks of GE Healthcare Companies.

CoolSNAP<sub>HQ</sub> is a trademark and Cascade is a registered trademark of Roper Scientific.

Evolve is a registered trademark of Photometrics.

Microsoft and Windows are registered trademarks of Microsoft Corporation.

All other registered names and trademarks referred to in this manual are the property of their respective companies.

GE Healthcare  
1040 12th Ave. NW  
Issaquah, WA 98027  
(425) 557-1000 FAX: (425) 557-1055

## Table of Contents

About This Manual .....	i
Document Conventions .....	ii
Lists and Procedures .....	ii
Notes, Warnings, and Cautions .....	ii
User Interface Description Conventions .....	iii
<b>Chapter 1 - Introduction .....</b>	<b>1.1</b>
What is DeltaVision? .....	1.1
History .....	1.2
What Can You Use DeltaVision for? .....	1.3
Standard Data Collection Options .....	1.4
3D Imaging .....	1.4
Multiple Wavelengths .....	1.4
Panel Collection .....	1.4
Time-Lapse .....	1.4
Point Visiting .....	1.4
Autofocus .....	1.4
Köhler and Critical Illumination .....	1.5
Live Cell Imaging .....	1.5
Laser Photo-bleaching and Photo-activation .....	1.5
TIRF (Total Internal Reflection Fluorescence) .....	1.5
What Should You Know to Use DeltaVision? .....	1.6
<b>Chapter 2 - Safety .....</b>	<b>2.1</b>
Warning Labels .....	2.2
UV Exposure .....	2.2
Bright Light Exposure .....	2.3
Laser Hazards .....	2.3
Burn .....	2.3
Shock .....	2.3
Xenon Lamp Safety .....	2.4
Explosion .....	2.4
High Voltage .....	2.4
UV, Visible, and IR Radiation .....	2.4
Thermal Hazards .....	2.4
Disposal .....	2.5
Damage Prevention .....	2.5
<b>Chapter 3 - Getting Started .....</b>	<b>3.1</b>
Before you start .....	3.1
Books on Cell Biology Methods .....	3.2
Papers on Sample Preparation .....	3.2
Courses in Microscopy and Cellular Imaging .....	3.2
Getting Familiar with DeltaVision .....	3.2
Controlling the Light path .....	3.3

Focusing .....	3.3
Choosing Filters .....	3.4
Using the Keypad and Joystick .....	3.6
Acquire Image .....	3.6
Ex Shutter .....	3.6
Blank Screen .....	3.6
Trans Shutter .....	3.7
Slow, Medium, and Fast .....	3.7
EX Arrow Keys .....	3.7
ND Arrow Keys .....	3.7
Z Arrow Keys .....	3.7
Point Mark .....	3.7
The Joystick .....	3.7
Turning DeltaVision On .....	3.7
Acquiring and Saving Data .....	3.10
Setting Up the Sample for Image Acquisition .....	3.10
Acquiring an Image .....	3.15
Saving Image Data .....	3.17
Setting up a Personal Data Folder .....	3.17
Saving a Single-Section, Multi-Channel Image .....	3.18
Turning DeltaVision Off .....	3.19

## Chapter 4 - Setting Up and Running Experiments ..... 4.1

Creating and Running an Experiment Macro .....	4.1
Sectioning Specimens for 3D Images .....	4.3
Guidelines for Designing/Running 3D Experiments .....	4.6
Focus point when scan starts .....	4.6
Optical section spacing .....	4.7
Number of optical sections .....	4.8
Sample thickness .....	4.8
Selecting Filters .....	4.8
Choosing Filters .....	4.9
Point Visiting .....	4.10
Marking Points .....	4.11
Editing a Point List .....	4.14
Loading a Point List and Specifying Points to Visit .....	4.15
Monitoring Point Visiting Experiments with Point Track .....	4.18
Setting up Time-lapse Experiments .....	4.19
Using the Actions Tab with Time-lapse Experiments .....	4.20
Laser Event .....	4.24
UltimateFocus .....	4.25
Autofocus .....	4.25
Cell Track .....	4.26
Pause .....	4.26
Wait .....	4.27
Change Time-lapse .....	4.27
Ratio Image .....	4.27
Add Log Note .....	4.28
Trigger TTL .....	4.28

Custom .....	4.29
Sending TTL Triggers to External Devices .....	4.29
Collecting Panel Images over Large Areas .....	4.30
Determining Border Rolloff Voxels .....	4.30
Collecting Panel Images .....	4.31
<b>Chapter 5 - Acquiring Data from Live Specimens .....</b>	<b>5.1</b>
Using Autofocus in Experiment Macros .....	5.1
Tracking Cells .....	5.3
Guidelines for specifying Cell Tracking Options .....	5.6
Tracking Method .....	5.6
Reference Channel .....	5.6
Move Threshold .....	5.7
ROI Percent .....	5.8
Acquiring 2D Z Projections with OAI .....	5.8
Z Sweep Acquisition versus Traditional Projections .....	5.9
Using Z Sweep Acquisition .....	5.10
Acquiring a Reference Image .....	5.11
<b>Chapter 6 - Localization Microscopy .....</b>	<b>6.1</b>
Localization Microscopy Overview .....	6.1
Localization Microscopy Experiments .....	6.2
Dense Stochastic Sampling Imaging (DSSI) .....	6.6
Acquiring Localization Images .....	6.7
Before Starting a Localization Experiment .....	6.7
Using the Beam Concentrator .....	6.7
Calibrating the Camera for Localization Imaging .....	6.7
Localization Setup .....	6.8
Running a Localization Imaging Experiment .....	6.12
Using the Localization Progress Monitor .....	6.15
During Acquisition .....	6.16
<b>Chapter 7 - Data Collection Techniques .....</b>	<b>7.1</b>
Finding a Specimen and Recording its Slide Holder Position .....	7.1
Finding Exposure Times .....	7.4
Using Köhler and Critical Illumination .....	7.5
Köhler/Critical Switching with API FI .....	7.5
Field Stop Aperture (Closed <-> Open) .....	7.6
Critical/Köhler Illumination Switching .....	7.6
Köhler/Critical Switching with Olympus FI .....	7.6
Monitoring Data Acquisition .....	7.8
Viewing Deconvolved Image Previews .....	7.8
Selecting Viewing Modes .....	7.9
Displaying Statistics and the Histogram .....	7.10
Editing Experiment Macros .....	7.11
Search & Replace .....	7.11
Status Area .....	7.12

Macro Text Area .....	7.12
Commands List .....	7.12
Using Ratio Imaging .....	7.13
Using the Microtiter Stage Option .....	7.18
Before Operating the Microtiter Stage .....	7.19
Loading a Microtiter Plate .....	7.20
Exploring a Microtiter Plate .....	7.22
Designing a Plate Scan Experiment .....	7.23
Running a Microtiter Plate Scan .....	7.33
Reviewing a Finished Plate Scan .....	7.34
Re-scanning Selected Wells .....	7.35
Re-scanning Selected Panels with a Different Objective .....	7.36
Adding Overlays to the Microtiter Overlay Window .....	7.38
Using UltimateFocus .....	7.39
Monitoring Stage Corrections .....	7.41
Tips for Focus Maintenance .....	7.42
Focus Maintenance with Long Time-lapse Experiments .....	7.42
Focus Maintenance with Medium Time-lapse Experiments .....	7.43
Focus Maintenance with Very Short Time-lapse Experiments .....	7.43
Multi-well Plate Scanning with UltimateFocus .....	7.43

## **Chapter 8 - Facility Requirements/Components ..... 8.1**

Electrical and Environmental Requirements .....	8.2
Electrical Requirements .....	8.2
Line Requirements .....	8.2
Power Cord Set Requirements .....	8.2
Environmental Requirements .....	8.3
General Environmental Requirements .....	8.3
Communication Recommendations .....	8.4
Air Movement .....	8.4
Vibration Isolation .....	8.4
Ambient Illumination .....	8.4
Dust .....	8.5
Overview of Components .....	8.5
Standard DeltaVision Components .....	8.5
Standard personalDV Components .....	8.6
Optical Components .....	8.6
Fluorescence Microscope .....	8.6
Optical Filters .....	8.7
Fluorescence Illuminators .....	8.7
Olympus Fluorescence Illumination Module .....	8.7
Automated Fluorescence Illumination Module .....	8.8
Cameras .....	8.11
PCO Edge CMOS Camera .....	8.11
Configuring the PCO Edge sCMOS Camera for Fast Imaging .....	8.12
Application Tips .....	8.14
CoolSNAP HQ2 CCD Camera .....	8.14
ES2 CCD Camera .....	8.16
Photometrics Evolve Camera .....	8.16

Light Sources .....	8.18
Xenon Lamp .....	8.19
InsightSSI (Solid State Illumination) .....	8.20
LED Transmitted Light .....	8.22
Desktop Components .....	8.23
Flat-Panel Display Monitor .....	8.23
The Keypad and Joystick .....	8.24
Vibration Isolation Table .....	8.24
Cabinet Components .....	8.25
Instrument Controller / Microscope Interface Chassis (IC/MIC) .....	8.25
Workstation .....	8.26
Other Standard Components .....	8.26
The Repeatable Slide Holder .....	8.26
Calibration Kit .....	8.27
The Tool Kit .....	8.28
Software .....	8.28
softWoRx .....	8.28
Optional Components .....	8.29
The Environmental Chamber .....	8.30
Basic Environmental Chamber Components .....	8.31
The Microtiter Stage Option .....	8.37
Additional Filter Modules .....	8.38
TIRF/PK Module .....	8.38
X4 Laser Module .....	8.39
Laser Safety using the X4 Laser Module .....	8.39
Using the X4 Laser Module .....	8.40
X4 Laser Module and TIRF .....	8.41
TIRF-specific Laser Safety Considerations .....	8.42
Imaging Using TIRF .....	8.42
Photokinetic (PK) Experiments .....	8.44
The UltimateFocus Module .....	8.46
Analysis Workstations .....	8.46
Software .....	8.47
softWoRx Explorer .....	8.47
softWoRx Suite for Windows Option .....	8.47
softWoRx Suite Advanced Option .....	8.47
softWoRx DMS .....	8.47
Differential Interference Contrast (DIC) Module .....	8.47
DIC Optics .....	8.48
Installing the DIC Module .....	8.49
Aligning the DIC Module .....	8.50
Setting Up DIC .....	8.61
Consumable Parts .....	8.66
Common to 100-120 V and 220-240 V Systems .....	8.66
Bulbs (If applicable) .....	8.66
British Power Cord .....	8.66

## Chapter 9 - Changing Cameras and Filters ..... 9.1

Changing Cameras .....	9.1
------------------------	-----

Using Live Cell or Custom Filter Wheel Modules .....	9.3
Changing Filter Wheel Modules .....	9.4
Before You Begin .....	9.5
Changing the EX Filter Wheel .....	9.5
Changing the EM Filter Wheel .....	9.7
Changing the EP Filter Wheel .....	9.9
Completing the Filter Wheel Change .....	9.11
Calibrating the Filter Wheels .....	9.12
<b>Chapter 10 - Maintenance .....</b>	<b>10.1</b>
Shutting Down and Starting the System .....	10.1
DeltaVision Power Switches .....	10.1
Guidelines for Using Switches .....	10.2
Main Components .....	10.2
Workstation, IC/MIC, and Monitor .....	10.2
Shutting Down the System .....	10.3
Starting the System .....	10.3
Replacing the Xenon Bulb .....	10.3
Replacing IC/MIC Fuses .....	10.9
Cleaning the System .....	10.10
Moving the System .....	10.10
<b>Appendix A - The Immersion Oil Kit .....</b>	<b>A.1</b>
The Oil Calculator .....	A.1
Distance from Coverslip to Specimen (microns) .....	A.1
Temperature .....	A.1
Specimen Refractive Index .....	A.2
Recommended Refractive Index .....	A.2
Resolution Ratio .....	A.2
Maximum XY Pixel Size .....	A.2
Recommended Z Step .....	A.2
<b>Appendix B - Troubleshooting .....</b>	<b>B.1</b>
Diagnosing System Problems .....	B.1
Troubleshooting the Controller .....	B.1
Troubleshooting the Workstation .....	B.2
Analyzing Reasons for Poor Image Quality .....	B.2
<b>Appendix C - Acquiring a PSF .....</b>	<b>C.1</b>
Before You Start .....	C.1
Acquiring a PSF .....	C.1
Tools .....	C.2
Selecting the Correct Immersion Oil .....	C.4
Converting PSF to OTF .....	C.5
PSF to OTF Conversion .....	C.6
PSF File .....	C.6



OTF File .....	C.7
X Range .....	C.7
Y Range .....	C.7
Z Range .....	C.7
T Range .....	C.7
Wavelengths .....	C.7
Lens ID .....	C.7
Sub-Image: Center .....	C.7
Sub-Image: Size .....	C.7
Additional Parameters: Border Rolloff (voxels) .....	C.7

## **Appendix D - Reference Information ..... D.1**

Standard Filename Extensions .....	D.1
Standard Fluorescence Filters .....	D.2
InsightSSI Module .....	D.2
Xenon Arc Lamp .....	D.3
Additional Reading Material .....	D.4
Microscopy .....	D.4
Linux Operating System .....	D.9
Image Processing .....	D.10
Optics .....	D.10

## **Appendix E - Resolve3D & Keypad Use ..... E.1**

The Resolve3D Window .....	E.1
The Resolve3D Menu .....	E.2
The Resolve3D File Menu .....	E.3
The Resolve3D View Menu .....	E.4
The Resolve3D Options Menu .....	E.4
The Resolve3D Calibration Menu .....	E.5
The Resolve3D Help Menu .....	E.6
The Resolve3D Toolbar .....	E.6
Image Control Fields .....	E.7
Stage Position Control Fields and Buttons .....	E.9
Stage Control and Display Tools .....	E.10
Image Intensity and Scale Values .....	E.14
Min, Max, Mean .....	E.14
Io .....	E.14
Histogram .....	E.14
Scale Min/Max .....	E.14
The Message Pane .....	E.14
Resolve3D Shortcuts .....	E.14
Acquire .....	E.15
Snapshot .....	E.15
Mark point .....	E.15
Blank Screen .....	E.15
The Design/Run Experiment Window .....	E.15
Experiment name .....	E.16
Use Fast Acquisition .....	E.16

Sectioning Tab .....	E.16
Channels Tab .....	E.16
Time-lapse Tab .....	E.16
Points Tab .....	E.16
Panels Tab .....	E.16
Plate Tab .....	E.17
Actions Tab .....	E.17
Experiment Name and Use Fast Acquisition .....	E.17
Experiment name .....	E.17
Use Fast Acquisition .....	E.17
Sectioning Setup .....	E.17
Focus point when scan starts .....	E.18
Optical section spacing .....	E.18
Number of optical sections .....	E.18
Sample thickness .....	E.18
Get Thickness .....	E.18
OAI .....	E.18
Channels Setup .....	E.19
Active Wavelength Check Boxes .....	E.19
Exp .....	E.19
EX Filter .....	E.19
EM Filter .....	E.19
%T Filter .....	E.19
Polychroic .....	E.20
Reference Image .....	E.20
Refresh exposure conditions .....	E.20
Time-lapse Setup .....	E.20
Time-lapse option .....	E.20
Time-lapse .....	E.20
Total Time .....	E.21
Time Points .....	E.21
Enable Cell Tracking .....	E.21
Cell Tracking Options .....	E.21
Maintain Focus with UltimateFocus .....	E.21
UltimateFocus Options .....	E.21
Image-based Autofocus before imaging .....	E.22
Autofocus Options .....	E.22
Point Visiting Setup .....	E.22
Visit Point List .....	E.23
Maintain Focus with UltimateFocus .....	E.23
UltimateFocus Options .....	E.24
Image-based Autofocus before imaging .....	E.24
Autofocus Options .....	E.24
Panel Collection Setup .....	E.24
Collect Panels .....	E.25
Overlap (pixels) .....	E.25
Start Coordinates .....	E.25
End Coordinates .....	E.25
PhotoKinetics Tab .....	E.25
Running Photokinetic (PK) Experiments .....	E.26

The Run Tab .....	E.27
The Green Arrow Button .....	E.28
Image file name .....	E.28
Image title .....	E.28
Add note to log .....	E.28
Change next time lapse .....	E.28
Schedule Post-Acquisition Processing Tasks .....	E.29
Images acquired/requested: .....	E.29
Disk space required .....	E.29
Elapsed time: .....	E.29
Estimated Finish .....	E.30
Current command: .....	E.30
The Cancel Scan Button .....	E.30
Help .....	E.30
The Settings Window .....	E.30
Settings Window Display Options .....	E.30
Image Display Mode .....	E.31
Window .....	E.31
Wave .....	E.31
Calculate statistics .....	E.31
Calculate histogram .....	E.31
Auto histogram range .....	E.31
Display images .....	E.31
Deconvolve preview images .....	E.31
Auto intensity scale .....	E.32
Acquire after point visit .....	E.32
Show alignment target (crosshairs) .....	E.32
Settings Window Files Options .....	E.32
Data Folder .....	E.33
Experiment macros folder .....	E.33
Data folder is temporary .....	E.33
Auto-increment file names .....	E.33
Convert to 2 byte signed integer .....	E.34
Settings Window Imaging Options .....	E.34
Camera .....	E.34
Frames to average .....	E.34
Gain .....	E.34
Transfer speed .....	E.34
Target temperature .....	E.35
Current temperature .....	E.35
Use photosensor .....	E.35
Settings Window Illumination Options .....	E.35
"EX 1" and EX 2" bulb age (hours) .....	E.35
Use Beam Conditioner .....	E.36
Field Stop Aperture (Closed <-> Open) .....	E.36
Critical/Köhler Illumination Switching .....	E.36
Settings Window Autofocus Options .....	E.37
Automatically determine parameters .....	E.37
Channel for Autofocus .....	E.37
Contrast calculation method .....	E.37

Autofocus Z test step (mm) .....	E.37
Maximum Z test range (mm) .....	E.37
Post-autofocus Z offset (mm) .....	E.38
Calibrate UltimateFocus for Plate Scanning .....	E.38
Settings Window Lasers Options .....	E.38
The PhotoKinetic Response Tab .....	E.39
The Spot Alignment Tab .....	E.40
TIRF Illumination Settings .....	E.41
Settings Window Misc Options .....	E.42
Allow Lost Motion Compensation (LMC) .....	E.42
Spiral Mosaic .....	E.42
Show stage trails .....	E.42
Show stage thumbnails .....	E.42
Show point numbers .....	E.42
Filter Wheel Sets .....	E.43
Activate Filter Sets .....	E.43
Action Buttons .....	E.43
Done .....	E.43
Save Settings .....	E.43
Help .....	E.43
Keypad/Joystick Operation .....	E.44
12-key Keypad/Joystick .....	E.44
Acquire Image .....	E.44
EX Shutter .....	E.44
Blank Screen .....	E.44
Trans Shutter .....	E.45
Slow, Medium, and Fast .....	E.45
EX Arrow Keys .....	E.45
ND Arrow Keys .....	E.45
Z Arrow Keys .....	E.45
Point Mark .....	E.45
The Joystick .....	E.45
46-key Keypad/Joystick .....	E.45
RESET .....	E.46
CONTROL MODE .....	E.46
LMC RESET ON/OFF .....	E.46
REMOVE TRAIL .....	E.46
KEYLIGHT ON/OFF .....	E.46
BLANK SCREEN .....	E.47
SLOW/MEDIUM/FAST .....	E.47
DISABLE MOTION KEYS .....	E.47
ACQUIRE MODE ARROWS .....	E.47
JOYSTICK .....	E.47
POINT ARROWS .....	E.47
ND and EX ARROWS .....	E.47
ACQUIRE IMAGE .....	E.47
SAVE IMAGE .....	E.47
STEP DECREASE/INCREASE .....	E.47
X AND Y ARROW KEYS .....	E.47
Z ARROW KEYS .....	E.47

Z1 MARK/Z2 MARK .....	E.48
EX SHUTTER .....	E.48
TRANS SHUTTER .....	E.48
POINT MARK .....	E.48

## Appendix F - Lasers and Safety Issues ..... F.1

Olympus FI Laser Safety .....	F.1
Important Safety Recommendations .....	F.2
Safety Features .....	F.2
Avoiding Specific Hazards .....	F.4
DURING USE: .....	F.5
BEFORE BEGINNING MAINTENANCE: .....	F.5
TIRF-specific Laser Safety Considerations .....	F.6
X4 Laser Module Safety Labeling .....	F.6
Standard Configuration .....	F.6
Optional Configurations .....	F.7
X4 Safety Label Locations .....	F.8
X4 Laser Source Chassis .....	F.8
X4 Laser Optics Module .....	F.10
DeltaVision Stage .....	F.12
Polychroic Beam Splitter Removal Screw .....	F.12
CE Label .....	F.13
Automated Fluorescence Illumination Module Safety .....	F.13
Important Safety Recommendations .....	F.14
Safety Features .....	F.14
Avoiding Specific Hazards .....	F.16
DURING USE: .....	F.17
BEFORE BEGINNING MAINTENANCE: .....	F.17
TIRF-specific Laser Safety Considerations .....	F.18
Auto FI Safety Labeling .....	F.19
Standard Configuration .....	F.19
Optional Configurations .....	F.20
Safety Label Locations .....	F.21
Laser Source Chassis .....	F.21
Laser Safety Labels with Auto FI Module .....	F.24
DeltaVision Stage .....	F.28
CO2 Chamber / TIRF Cover .....	F.29
Labels for Polychroic Turret Removal .....	F.29
X4 Module Laser Launch Safety Labels .....	F.30
Compliance Labels .....	F.31

## Appendix G - DeltaVision - Declaration of Hazardous Substances (DoHS) ..... G.1

## Index ..... 1.3



# Preface

---

This manual describes how to perform the tasks necessary to safely operate your DeltaVision Imaging System. This topic includes the following sections:

- **About This Manual** describes who should read this manual and generally how the manual is organized.
- **Document Conventions** explains the typography, symbols, and other conventions used in this manual.

## About This Manual

This manual provides instructions for scientists who are using *DeltaVision* to acquire data. It also includes instructions and references for maintaining the system.

The *Introduction* provides a brief summary of the *DeltaVision* system features. Safety warnings and guidelines are provided in Chapter 2.

Chapters 3 - 6 show how to use the system to acquire data.

- Chapter 3, *Getting Started*, describes how to turn the system on, acquire an image, and run an experiment macro.
- Chapter 4, *Setting Up and Running Experiments*, shows how to set up experiment macros for 3D sectioning, Time lapse, Multiple wavelengths, Paneling (for stitching), and Point visiting.
- Chapter 5, *Acquiring Data From Live Specimens*, provides information on how to use the DeltaVision system to collect images from live specimens.

- Chapter 6, *Localization Microscopy*, provides an overview of localization microscopy and describes how to set up, run, and analyze the results of localization imaging experiments.
- Chapter 7, *Data Collection Techniques*, describes how to determine the proper exposure time and provides guidelines for finding the areas of interest on a sample.
- Chapter 8, *Facility Requirements and Components*, lists requirements and describes the standard and optional DeltaVision system components.

The remaining chapters provide information on how to maintain and configure the system.

- Chapter 9, *Changing Cameras and Filters*, describes how to replace cameras, how to install or replace filters, and how to calibrate filter wheels.
- Chapter 10, *Maintenance*, shows how to shut down and start the system, replace a xenon bulb, replace fuses, clean the system, and move the system.
- The appendices include reference information, procedures for configuring the system, and laser-specific safety information.

## Document Conventions

In order to make the information in this manual as easy as possible for you to locate and use, the following conventions are observed.

### Lists and Procedures

- Round bullets indicate items in a list or choices in a procedure.
  - Hollow round bullets indicate a bulleted list of items embedded within another list.
- Arrow bullets indicate single-step procedures.
- 1. Numbered items indicate sequential steps for completing a procedure.
  - a. Alpha-numbered items indicate sequential steps embedded within a procedure.
    - i. Lower-case, roman-numbered items indicate a third level of embedded steps within procedures.
- ◆ *Diamond bullets indicate chapter summary items.*

### Notes, Warnings, and Cautions



**Note** Indicates information about the previous paragraph or step in a procedure.

---



**Important** Indicates important or critical information about the previous paragraph or step in a procedure.

---





**Tip** Indicates helpful advice.

---



**WARNING!** Indicates important information regarding potential personal injury.

---



**LASER WARNING!** Indicates important information regarding potential personal injury due to hazardous radiation.

---



**CAUTION!** Indicates important information regarding potential damage to the equipment or software.

---

## User Interface Description Conventions

**Boldface** indicates the names of buttons, menus, dialog box options/fields.

Initial Capitals indicate the names of windows, dialog boxes, and tabs.

ALL CAPITALS SAN SERIF indicates the name of a key on your keyboard, such as ENTER or DELETE.

**Uniform width font** indicates text to enter on a command line.



# 1. Introduction

---

This chapter provides an introduction to *DeltaVision*.

- *What is DeltaVision?* introduces the *DeltaVision* system and provides a history of its development.
- *What Can You Use DeltaVision for?* lists the supported imaging modes and summarizes the data acquisition options that are supported by *DeltaVision*.
- *What Should You Know to Use DeltaVision?* summarizes the background and experience required to run the system.

## What is DeltaVision?

The *DeltaVision* Imaging System can be used to collect and analyze three-dimensional microscope images, acquired over long periods of time and on multiple samples. With the sophisticated *softWoRx* image analysis and model-building software, the system is a comprehensive package for biological image data collection, interpretation, and display.



## History

The original restoration microscopes were designed and developed in the laboratories of Dr. John W. Sedat and Dr. David A. Agard at the University of California, San Francisco. Their first working system actively collected images as early as 1983. At that time, a *small* deconvolution (128x128x64) required overnight processing on a million dollar mainframe computer.

During the evolution of the UCSF microscope, it became clear that micropositioning was a critical part of the optical sectioning process. In particular, controlled movement of the focal plane relative to the specimen (the Z axis) was identified as a key to reliable deconvolution. To accomplish adequate Z scans, Dr. Sedat built a microscope stage using Applied Precision's Nanomotion™ micropositioning technology.

Before long, Dr. Sedat contacted Applied Precision cofounder Ron Seubert for detailed information about Nanomover performance. The relationship between UCSF and Applied Precision grew steadily. Later, in 1993, Applied Precision licensed the image restoration technology from UCSF and began development of DeltaVision. Collaboration between Applied Precision and UCSF still continues,

In October of 1993, Applied Precision shipped the first Applied Precision/UCSF hybrid to Michael Paddy at the University of Florida. In 1994, Applied Precision designed, built, and delivered a DeltaVision prototype to Paul Goodwin at the Fred Hutchinson Cancer Research Center, Seattle. In August 1994, the first commercial DeltaVision microscope was shipped to Bethe Scalettar at Lewis & Clark College, Portland, Oregon. All three of these systems are still active. The DeltaVision software has grown continuously since 1983, with contributions from scientific programmers, faculty, and graduate students at UCSF. Applied Precision's contribution to the software started in earnest in 1994.

The advances in computer and camera technology in the early 1990s resulted in the emergence of optical sectioning technology. For example, in 1993 Applied Precision's benchmark deconvolution ( $512 \times 512 \times 64$ ) required 3 hours of processing time on a \$35,000 workstation. (The benchmark deconvolution is 16 times larger than the original deconvolutions performed in 1983.) Although only a few laboratories were able to afford \$35,000 for a computer, the lower cost warranted commercialization of a deconvolution microscope. In 1996, the same deconvolution required about a quarter of an hour with a \$14,000 workstation, and half an hour with an \$8000 machine. This thirty-fold increase in performance/price allowed a more widespread acceptance of deconvolution microscopy.

Advances in computing power and data storage have continued to benefit *DeltaVision* users. In 2003, a \$2500 workstation could perform the standard benchmark in less than four minutes, representing another twenty-fold increase in performance/price since 1996. The current workstations can now perform this benchmark in less than 30 seconds (under 20 seconds for *DeltaVision* and under 30 seconds for *personalDV*). Vast amounts of data generated by these experiments can be stored on local hard drives, by burning DVDs, or by transferring the data to other locations using high-speed network connections.

As part of a continuing commitment to advancing Cellular Imaging and analysis, GE Healthcare Life Sciences acquired Applied Precision Inc. (API) in May 2011. Since the acquisition, API (now part of GE Healthcare Bio-Sciences) has continued to supply microscopy systems and provide support for *DeltaVision* imaging systems from its headquarters in Issaquah, WA (USA).

## What Can You Use *DeltaVision* for?

*DeltaVision* imaging systems use research grade microscopes to collect optical images in one of the following imaging modes:

- Fluorescence
- Brightfield
- Phase contrast
- <sup>\*1</sup>Differential Interference Contrast (DIC)

The following table summarizes the capabilities of the *DeltaVision* system.

Capability	Description
Digital Microscopy	Fluorescence Imaging. Also capable of Brightfield, Phase Contrast, and DIC imaging.
Automated Optical Sectioning, Time-lapse, Point visiting	Optical sectioning, filter changes, and shutters are coordinated by the controller.
Quantitative Processing	Image processing and 3-D reconstructions of multi-dimensional data files.

---

1. <sup>\*</sup> Phase contrast requires additional equipment that is available from Olympus distributors.

---

Image Display and Analysis	3-D reconstructions can be visualized, rotated, and enhanced.
----------------------------	---

---

*DeltaVision* supports a wide array of imaging applications, including: Cytoskeletal Studies, RNAi experiments, Live Cell Imaging, Cell Cycling Studies, Protein Translocation, Protein Pathway Analysis, and Localization.

## Standard Data Collection Options

DeltaVision supports the following types of data acquisition:

### 3D Imaging

To acquire “3D data,” you can set up DeltaVision to acquire a series of images along the Z axis. The *softWoRx* workstation provides a sleek interface that allows you to control the optical sectioning through a specimen. Behind the scenes, macro language provides automated computer control of sample position, optical filters, and shutters. After image data acquisition, a series of image processing algorithms improve image resolution. Three-dimensional information can be reconstructed and then visualized in a variety of ways that allow quantitative measurement and analysis.

### Multiple Wavelengths

DeltaVision can sequentially acquire images through multiple wavelengths and combine them into a single image file.

### Panel Collection

Panel collection acquires a series of images with adjacent fields of view. You can stitch these images together to create images that are much larger than a single field of view. This is especially useful when you want to collect data at a high magnification over a large area.

### Time-Lapse

You can run macros to acquire time-lapse images and use the data to create time-lapse movies. This is especially useful for studies of live samples or for experiments that use lasers.

### Point Visiting

Point Visiting allows you to acquire data from several areas of interest during a single experiment. You can select which points to monitor on your sample and save them in a list that contains the exact stage coordinates of each point. When you run the experiment, DeltaVision reads the coordinates for the points in the list, moves the stage to each point, and captures an image. This process is repeated at specified time-lapse intervals. For live specimens, this significantly improves the lab efficiency of experiments by allowing you to monitor multiple points of interest in a single session.

### Autofocus

You can use Autofocus to automatically focus DeltaVision when you are viewing a sample or when you are running an experiment.

After you have found focus and marked a point of interest, the optional UltimateFocus™ feature adds the ability to maintain focus during an experiment. The UltimateFocus Module uses an infrared laser that follows the illumination path and bounces off the cover slip/sample interface. The reflected beam is evaluated and the software returns an offset to the Z motor for automatic stage adjustment to maintain focus.

### Köhler and Critical Illumination

You can easily switch between Critical and Köhler Illumination. Köhler Illumination provides very even specimen illumination across the field of view. You will typically use Critical Illumination for most of your data collection. Critical Illumination only illuminates the area detected by the CCD. It therefore helps to preserve the biology and associated dyes outside the CCD's field of view. Köhler Illumination spreads the intensity of the light over the entire field of view of the oculars. The higher intensity light of Critical Illumination is also useful for low abundant probes that require more light. The current DeltaVision optics are optimized for Critical Illumination using a maximum 1K x 1K image size. With image sizes larger than this, using Kohler illumination is recommended due to edge roll-off.

### Live Cell Imaging

You can set up a controlled environment to acquire data from live specimens. DeltaVision supports an optional environmental chamber that you can use to control temperature and inject carbon dioxide.

DeltaVision also includes software that is specially designed to acquire data from live specimens:

- Cell tracking is used for point visiting time-lapse experiments. It automatically changes the coordinates of a point to follow a cell as it moves.
- Real-Time Z Sweep Acquisition (or Optical Axis Integration) allows you to quickly acquire 2D projections of specimens.
- Real-Time Deconvolution provides previews of deconvolved images as they are acquired.
- Reference Imaging is useful for acquiring reference images that can be used for Differential Interference Contrast (DIC) and other techniques.

### Laser Photo-bleaching and Photo-activation

If your system is equipped with the optional X4 Laser Module, you can use DeltaVision to run and analyze laser photo-bleaching and photo-activation experiments. The X4 Laser Module supports up to four lasers and provides software to control and to analyze the data that is obtained from these experiments.

### TIRF (Total Internal Reflection Fluorescence)

If your system has the optional X4 Laser Module and Auto FI, you can use DeltaVision to run and analyze multiline TIRF experiments. The TIRF technique is used in a number of research applications, such as cellular protein and vesicle trafficking, focal cellular adhesions, single biomolecule dynamics, studies in neuroscience, and cell-to-cell

communications. The ability to excite molecules on the surface of a specimen while eliminating the fluorescence from the depth of the sample makes TIRF a valuable tool for examining cell surface structure and protein dynamics.

For more information on the TIRF technique, see the section "*X4 Module and TIRF*" on Page 8.42.

## What Should You Know to Use DeltaVision?

This document assumes that you are familiar with the basics of microscopy. Correct operation of the microscope is fundamental to obtaining quality images with DeltaVision. In addition, an understanding of image processing basics will help you use the system to its full potential. To manage the computer systems, some familiarity with Linux workstations and Windows-based personal computers is helpful.

We have taken care to ensure that DeltaVision is straightforward to use, reliable, and complete. Please report errors and problems with DeltaVision to GE Healthcare at <http://www.api.com/2013support/> or alternatively, use the problem report form in *Appendix B: Troubleshooting*.



## 2. Safety

---

This chapter covers safety and damage prevention issues to be aware of when using a *DeltaVision* imaging system. The precautions detailed in this chapter must be carefully observed to prevent possible personal danger:



**Note** All laser-related safety issues, including proper labeling, are discussed in “Lasers and Safety Issues” on Page F.1.

- *UV Exposure* discusses potential for UV exposure from the xenon arc lamp.
- *Bright Light Exposure* warns about bright light exposure from the transmitted light source installed in the microscope.
- *Laser Hazards* explains that a *DeltaVision* system with lasers installed is considered a Class 3B device and warns that visible and invisible radiation from the installed lasers can exit the device at the same time and are powerful enough to potentially cause damage to the human eye.
- *Burn* provides guidelines for avoiding burns from the xenon arc lamp. (The arc lamp reaches very high temperatures.)
- *Shock* includes warnings about potential shock hazards. (Hazardous voltages are present even when the system is disconnected from the AC main power outlet.)
- *Damage Prevention* describes actions that can damage the system.
- *Warning Labels* describes the system labels.

Additional safety guidelines for maintenance and alignment are detailed in *Chapter 10: Maintenance*.

For laser safety considerations and laser safety labeling information, see *Appendix F: Lasers and Safety Issues*.

## Warning Labels

Various warning labels have been applied to the components of the system that pose a potential hazard to the user. The labels have been duplicated here and carefully explained. It is important that all users of the system read and understand these warnings.



### Hazardous Voltage Warning Label

This label indicates the danger of electric shock. This label is found on the xenon arc lamp housing.



### Caution or Warning Label

This label indicates a danger of personal injury or possible damage to equipment. It is accompanied by an explanation of the specific danger. This label may be found on the microscope, the lamp, the High Res camera, the Fast Camera, or the workstation.



### Laser Warning Label

This label indicates potential exposure to radiation. You will be advised of appropriate precautions whenever this warning is presented.

**Note:** Please see "Lasers and Safety Issues" on Page F.1 for detailed laser safety information.

## UV Exposure



**WARNING:** Since the excitation illumination module (xenon arc lamp or InsightSSI) emits ultraviolet (UV) light, there is a danger of exposing your eyes and skin. Loss of eyesight could occur if unfiltered light from the xenon arc lamp reaches your eyes.

### To prevent UV exposure:

- Open the shutter only when an excitation filter is engaged.
- Do not open the xenon arc lamp housing during operation. See *Chapter 10, Maintenance* for detailed instructions on changing the xenon arc lamp bulb.

## Bright Light Exposure

While the transmitted light source installed in the microscope does not present possible UV exposure, it could cause discomfort under certain conditions.



**WARNING:** You must be aware of the eyepiece filter wheel when viewing a specimen through the microscope oculars. Make sure that the proper filters are in place so that your eyes are not suddenly exposed to a bright flash of light when the transmitted light shutter is opened. **DO NOT** look through the eyepiece while switching filters. Your eyes can be exposed to unfiltered light during the filter transition.

## Laser Hazards



**WARNING:** The optional laser modules available for DeltaVision are considered Class 3B devices. The power level is high enough to cause damage to the human eye instantaneously and possible damage to the skin.

The optional *UltimateFocus*<sup>™</sup> Module complies with CFR 1040.10 and 1040.11 except for deviations pursuant to Laser Notice No. 50, dated June 24, 2007 IEC 60825-1, 2007-03.

OSHA regulations require (via ANSI Z136.1) and IEC 60825-1 recommends that a Laser Safety Officer be identified who will be responsible for the safe use of Class 3B lasers. This includes training users, installing all necessary warnings and controls in the laser area, and other duties.



Given the inherent exposure possible with an inverted frame microscope stand, users of the system *must be trained in laser safety before using this instrument*. Contact your lab administrator for information about Laser Safety training at your institution. Training information is also available online at: [www.kenteklaserstore.com](http://www.kenteklaserstore.com)

The International Electrotechnical Commission (IEC) and the FDA recommend that Class 3B and Class 4 lasers be used only in restricted areas.

Please see “Lasers and Safety Issues” on Page F.1 for detailed laser safety information.

## Burn



**WARNING:** The xenon arc lamp reaches a very high temperature when lit. Never touch the housing during operation. Never remove the housing during operation or before allowing it to cool completely. Carefully follow the directions found in *Chapter 10, Maintenance*, for changing the lamp.

## Shock



**WARNING:** Hazardous voltages are present even when the system is disconnected from the AC main power outlet. To replace the xenon arc lamp, follow the instructions found in *Chapter 10: Maintenance*. Refer also to the following section, “Xenon Lamp Safety,” for additional related safety issues. No other system components contain user-serviceable parts and do not warrant disassembly.

## Electromagnetic Environment

---



**WARNING:** This equipment is designed to operate in a controlled electromagnetic environment, such as in analysis, test, or service laboratories. If there is interference from other transmitters, as from some cellular phones, it is recommended to not use these transmitters in close proximity to this equipment.

---

## Xenon Lamp Safety

Xenon lamps are under high pressure and emit high levels of radiation. Proper handling procedures and safety precautions should be observed to assure the safety of the users of this product. Only operate this lamp within the recommended operating specifications as detailed in this manual. Refer to “*Replacing the Xenon Lamp*” in Chapter 10 of this manual for details on the proper procedures for lamp replacement.

## Explosion

---



**WARNING:** These xenon lamps are under high pressure. Use of face shields or safety glasses during handling is recommended. Avoid applying excessive shock or stress to the lamp during handling.

---

## High Voltage

---



**WARNING:** The ignition voltage of the xenon lamp presents a very high voltage hazard. Do not touch the lamp during operation. To avoid the risk of electrical shock, the input power should be disconnected prior to servicing the lamp.

---

## UV, Visible, and IR Radiation

---



**WARNING:** Xenon lamps emit high levels of radiation that can cause severe skin burns and permanent eye damage. Avoid direct exposure to the emitted or reflected beams.

---

## Thermal Hazards

---



**WARNING:** Xenon lamps can get very hot during and after operation (up to several hundred degrees C). To avoid potential for serious burns, do not touch the lamp during operation. Do not touch the lamp after operation until the lamp has adequately cooled.

---

## Disposal

It is recommended that the xenon lamp's internal pressure be relieved prior to disposal. This is accomplished by squeezing off the tip (see illustration below) with needle-nosed pliers until the pressurized gas escapes.

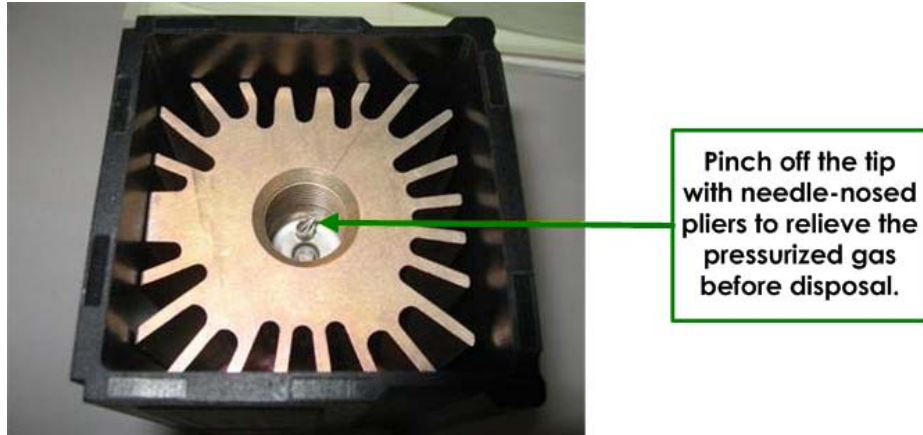

Figure 2.1 Relieve the xenon lamp's internal pressure before disposal!

Pressurized xenon lamps should not be incinerated, but disposed of in a landfill.

## Damage Prevention

The following actions could damage the system:

- Moving the stage to the home position with the objective up could break or scratch the objective. The stage could be driven into the objective and may potentially scratch the top lens or compress the lens housing, causing a leak, crack, or lens misalignment.
- Disconnecting cables before the system is completely shut down may damage one or more of the electronic circuit boards.
- Disconnecting cables to the camera when the power is on may damage the camera.
- Touching optical filters or the polychroic beam splitter contaminates them with oil and can lead to premature failure or poor image quality. For cleaning information, see *Chapter 10: Maintenance*.
- Bending the fiber optic cable into a coil with a diameter less than 24" will damage the cable.
- Using improperly rated replacement fuses can create a fire hazard and may result in damage to components. Use only the fuse types listed on the component or in the manual.
- Leaving a camera out of the tray when it is not in use presents an opportunity for the camera to fall to the floor and break. Always place the camera in the camera tray when it is not in use.



## 3. Getting Started

---

This chapter shows how to get started with DeltaVision.

- *Before you start* includes a checklist of things that you need to have before you can acquire images for your sample.
- Getting Familiar with DeltaVision describes the key controls that you will use to direct the light path, focus, and select filters. It also introduces the keypad and joystick.
- *Turning DeltaVision On* shows how to turn on the system.
- *Acquiring an Image* shows how to place the slide and the objective, find the sample, and acquire an image.
- *Saving Image Data* describes how to set up a personal data folder and how to save an image file.
- *Turning DeltaVision Off* shows how to turn off the system.

### Before you start

Before you start, make sure that you:

- Select the proper oil for your objective and specimen. The immersion oil kit includes 18 oils (6 for personalDV) with refractive indexes that range from 1.500 to 1.534, in increments of 0.002. (For personalDV, the kit includes 6 oils that range from 1.512 to 1.522.) To calculate the best refractive index for your application, follow the instructions in “Recommended Refractive Index” on Page A.2. If you are working at standard temperature and pressure, the oil

with a 1.516 refractive index is generally a good place to start. For work at 37 degrees C, use the oil with a 1.520 refractive index.

- Know your login ID and password for the workstation.
- Prepare your sample using the recommended practices that are documented in the following references. (If you are untrained in sample preparation, consider attending a course like the one shown below.)

## Books on Cell Biology Methods

Current Protocols in Cell Biology. Bonifacino, Dasso, Lippincott-Schwartz, Harford, Yamada ed. Wiley Press, <http://www.wiley.com/legacy/cp/cpcb/>

Cells, A Laboratory Manual. Spector, Goldman, Leinwand ed. Cold Spring Harbor Press, 1998.

Video Microscopy: The Fundamentals (2nd Edition). Inoue and Spring, Plenum Press, 1997.

Digital Microscopy (3rd Edition), Methods in Cell Biology Vol. 81. Sluder and Wolf, Academic Press, 2007.

## Papers on Sample Preparation

Rines DR, He X, Sorger PK. Quantitative microscopy of green fluorescent protein-labeled yeast. *Methods Enzymol.* 2002;351:16-34.

Hutchins JR, Moore WJ, Hood FE, Wilson JS, Andrews PD, Swedlow JR, Clarke PR. Phosphorylation regulates the dynamic interaction of RCC1 with chromosomes during mitosis. *Curr Biol.* 2004 Jun 22;14(12):1099-104.

## Courses in Microscopy and Cellular Imaging

In Situ Hybridization, Immunocytochemistry, and Live-cell Imaging. Dernberg, Hu, and Murray Course Directors, Cold Spring Harbor, October (annual).

Analytical and Quantitative Light Microscopy, Sluder and Wolf Course Directors, Marine Biological Laboratory, Woods Hole, MA, May (annual).

## Getting Familiar with *DeltaVision*

Before you acquire an image, become familiar with the key *DeltaVision* controls for:

- Controlling the Light Path
- Focusing
- Choosing Filters
- Using the Keypad and Joystick

Most of the manual controls for controlling the light path, focusing, and choosing filters are similar to those that you will find on any microscope. Additional controls for moving the stage and acquiring images are provided by the keypad and joystick.



## Controlling the Light path

*DeltaVision* provides a transmitted LED light and either a xenon arc lamp or a solid state illumination source. The transmitted light works the same as the light source for a traditional microscope, with the light path directed on the specimen from above. Both the xenon arc lamp and the InsightSSI (solid state illumination source) provide excitation light directed through the back of the microscope and focused on the specimen from below. You can use the Port Selector to direct the light path either to the **Eyepiece** or to the **Camera**.

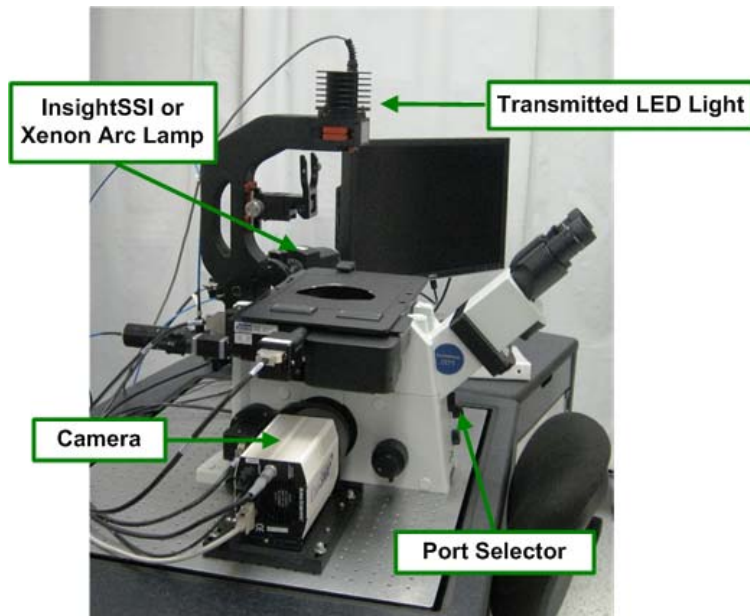

## Focusing

There are three manual focus controls and a Focus Lock on the *DeltaVision* microscope. These controls are similar to those on other microscope systems.

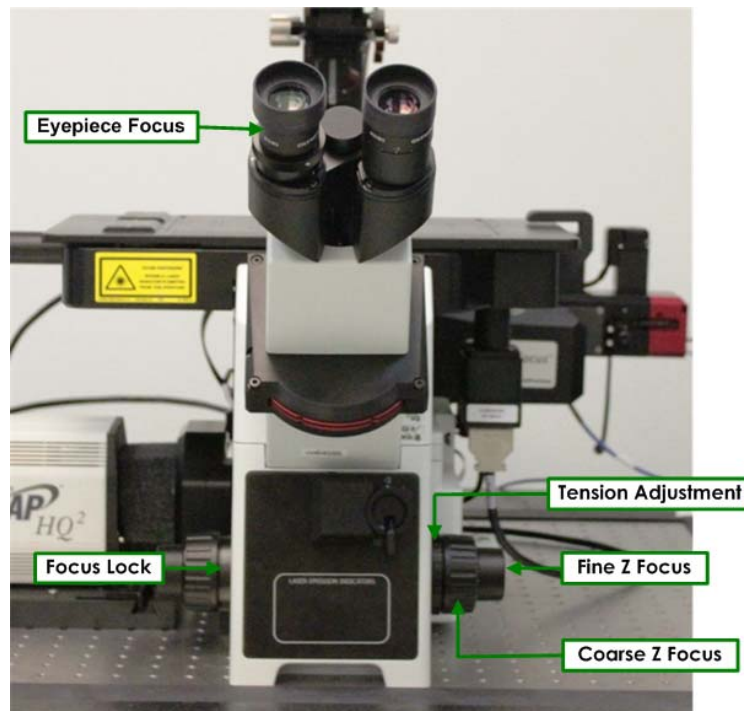

**Eyepiece Focus** – Use the Eyepiece Focus (on the left ocular) to adjust focus between the two oculars.

**Focus Lock** – Use the Focus Lock to set a maximum height for Z focus. This can keep users from hitting the sample with the objective.

**Tension Adjustment** – Use the tension adjustment on the focus knob to help keep the knob from moving inadvertently.

**Fine Z Focus** – Use the Fine Z Focus knob to move the objective in very small increments. It is used to focus on the focal plane.

**Coarse Z Focus** – Use the Coarse Z Focus knob to move the objective in large increments. It is typically used to lower the objective when the system is initialized or to move the objective up to the slide until the oil is touching the slide.

## Choosing Filters

Choosing and controlling filters is a key for any fluorescent probe experiment. When a fluorescent probe is excited by a specific wavelength, it emits light at another wavelength. Choosing the correct filters for the dyes in your sample allows you to obtain a complete set of data specifically from your probe without interference from other wavelengths.

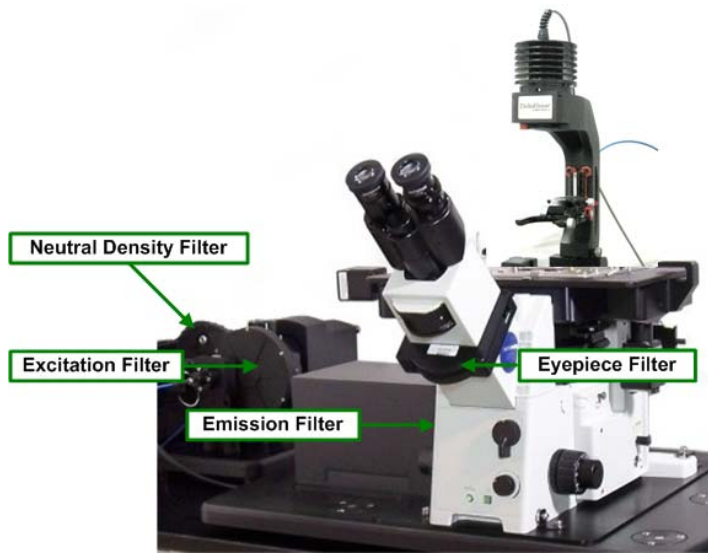

*DeltaVision* provides several different types of filters for controlling the fluorescent light path:

- **Neutral Density** filters/settings (often denoted as "%T") reduce the amount of light that illuminates your sample when you are using fluorescence. *DeltaVision* provides six neutral density filters that block from 0 to 99.9% of all light.
- **Excitation** filters/settings allow transmission of only a narrow band of wavelengths, providing a specific range of light to excite the fluorescent probes in the sample.



**Note** With the InsightSSI solid state illumination module, the excitation filters are included as part of the illumination module. Also, no neutral density filters are necessary when using InsightSSI as your broadband light source.

---

- **Polychromatic Beam Splitter** reflects the excitation wavelengths to the sample and transmits the emission wavelengths from the sample. *DeltaVision* ships with a standard polychromatic beam splitter for DAPI, FITC, TRITC, and Cy5. Other beam splitters ship with optional live-cell sets.
- **Emission** filters allow only a narrow band of light from the excited probe to reach the camera.
- **Eyepiece** filters are emission filters that allow only a narrow band of light from the excited probe to reach the eyepiece and your eyes.

These filters are arranged in sets that are associated with specific dyes. (For example, a dye such as DAPI is typically used with a DAPI Excitation filter, a DAPI Emission Filter, and a DAPI Eyepiece Filter.)

You can choose filter sets manually by rotating the eyepiece filter wheel. The filter sets are synchronized so that when you change an eyepiece filter, the neutral density filter, excitation filter, and emission filter automatically change.

## Using the Keypad and Joystick

The keypad and joystick are used to move the stage, open shutters, acquire images, and control other acquisition options. Key controls are shown below.



**Note** DeltaVision is currently being shipped with the 12-key Keypad/Joystick, as described below. For complete usage information on the 46-key Keypad/Joystick shipped previously with DeltaVision, see the appropriate section in *Appendix E, "Resolve3D and Keypad Options."*

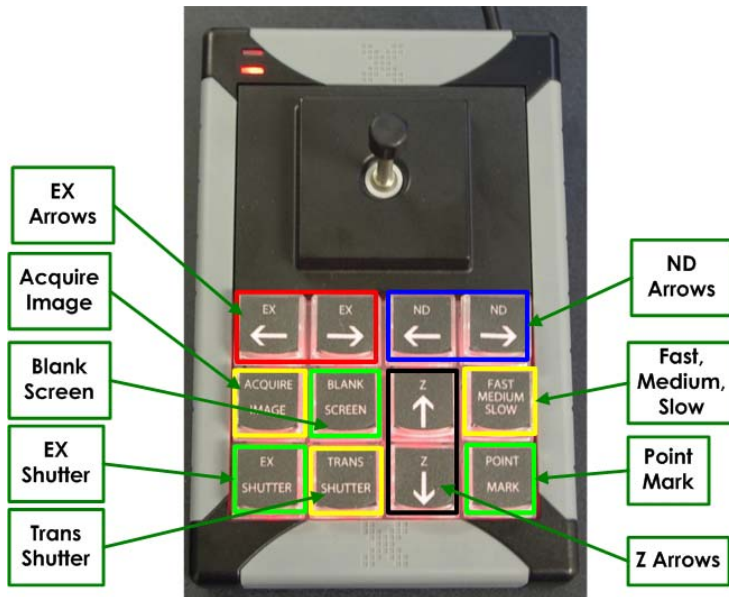

Figure 3.1 Key controls on the 12-key Keypad

### Acquire Image

With the microscope set to Camera Mode, this button acquires an image and displays it on the monitor. Use this key when you are scanning through your sample and want to get a quick look at the specimen on the monitor. (Note that Resolve3D must be running at the time.)

### Ex Shutter

Opens or closes the Excitation (i.e., Fluorescence) shutter. You will use this control frequently to open and close the shutter. Because the shutter is designed to protect your eyes from exposure to ultraviolet light, it automatically closes each time that the eyepiece filter wheel is moved. It must be reopened with the EX SHUTTER button.

### Blank Screen

Suspends (or activates) the monitor's light display (BLANK SCREEN is a toggle button). Use this feature when viewing dim samples or performing light sensitive experiments.

### Trans Shutter

Toggles the transmitted light LED between off and on. (Subsequent to changing the transmitted light source from halogen to LED, an actual shutter is no longer necessary.)

### Slow, Medium, and Fast

Control the speed that the stage is moved using the joystick. This key functions as a toggle. Each time the key is pressed, the controller moves to the next mode. The order is FAST, MEDIUM, and SLOW. Also, the green LED on the keypad provides the following indicators:

- When the FAST stage speed is selected, the green LED flashes twice.
- When the MEDIUM stage speed is selected, the green LED flashes once.
- When the SLOW stage speed is selected, the green LED does not flash at all.

It's usually best to start with the Medium stage speed.

### EX Arrow Keys

EX Left-arrow moves the selection to the previous EX filter location. EX Right-arrow moves the selection to the next EX filter location.



**Note** The order of the EX locations should match the configuration file EX table.

---

### ND Arrow Keys

ND Left-arrow moves the selection to the previous ND filter location. ND Right-arrow moves the selection to the next ND filter location.



**Note** The order of the ND locations should match the configuration file ND table.

---

### Z Arrow Keys

Moves the stage in the Z direction indicated.

### Point Mark

Adds the current stage position to the marked points list.

### The Joystick

Controls stage movement. Use the joystick to move the stage in the direction that you point with the joystick (for example, moving the joystick up moves the stage away from you, moving joystick left moves the stage to the left, and so on).

## Turning DeltaVision On

Use the following instructions to turn the system on for day-to-day use. For instructions that show how to turn on DeltaVision after a system shutdown, see "Starting the System" on Page 10.3.

### To turn on DeltaVision:

1. Turn on the IC/MIC.

2. Turn on the power strip bar.
3. Turn on any additional equipment such as cameras or the heater for the Environmental Chamber.

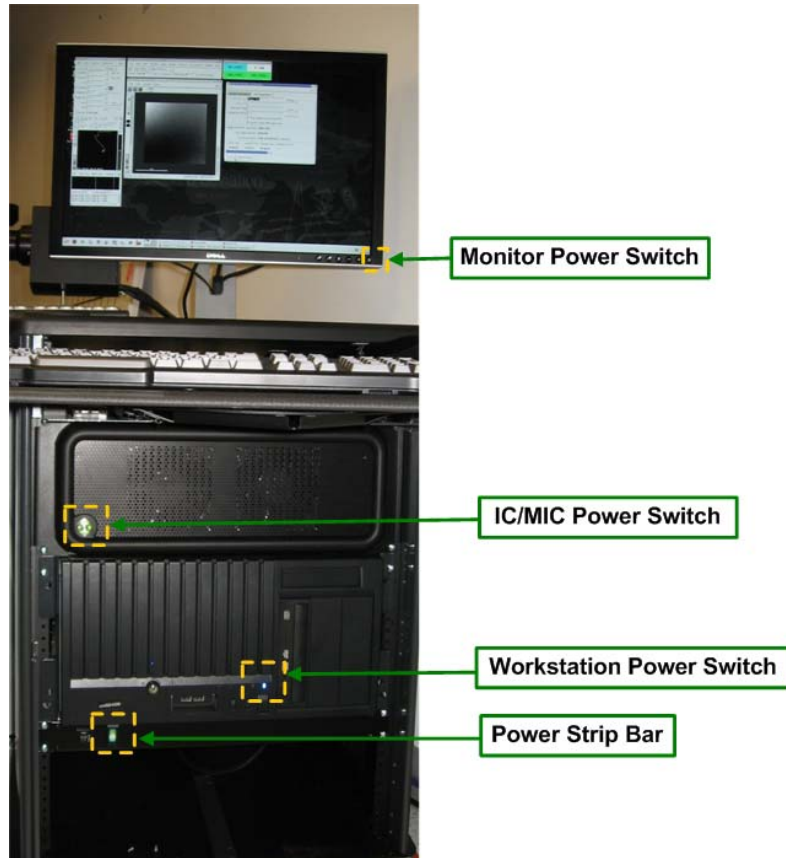



Figure 3.2 Main Power Switches (DeltaVision Cabinet)

4. If the monitor is off, turn it on.
5. If the Workstation is off, turn it on and wait for it to boot up.
6. Log on to the Workstation.
7. Remove any slides from the stage.
8. On the desktop, double-click the **Start softWoRx**  icon to open *softWoRx*.
9. On the *softWoRx* menu, choose **File | Acquire (Resolve3D)**.
10. Release the Focus Lock by turning it clockwise (when facing the lock) until it is loose.



11. Lower the objective by turning the Coarse Z Focus knob away from you when facing the knob (clockwise on the right-side knob).



**CAUTION!** Always lower the objective before you initialize the system to prevent damage to the objective lens.

---

12. A prompt is displayed reminding you to lower the objective before continuing. After you lower the objective, select **Initialize** to initialize the system.

The Resolve3D window, the Data Collection Window, and the Filter Monitor window are displayed on the desktop as shown.

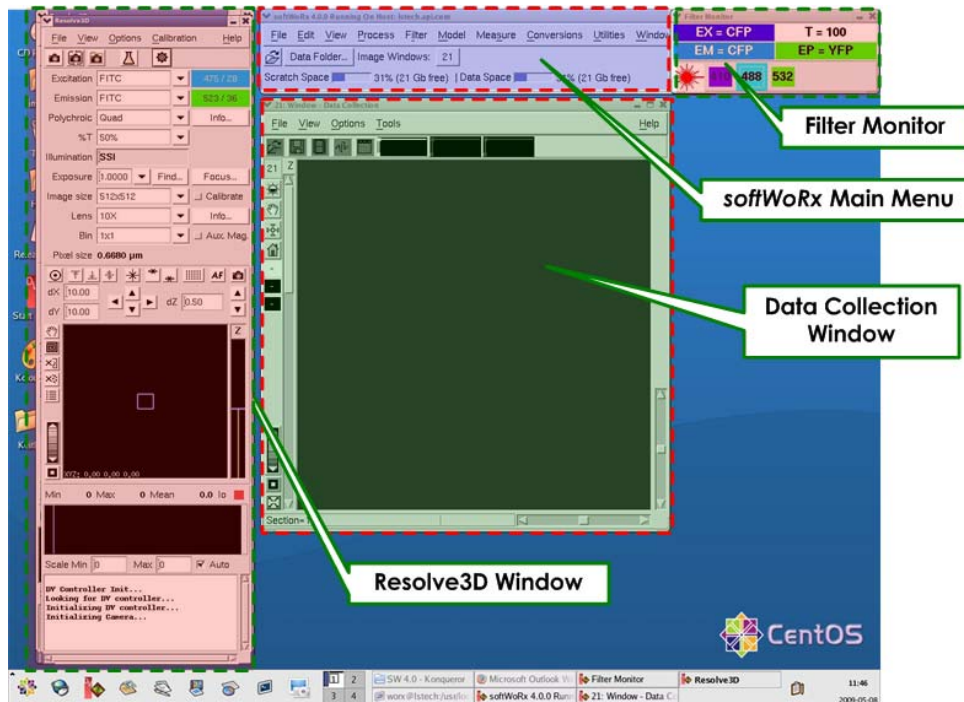

Figure 3.3 softWoRx Desktop Display

The Resolve3D window includes acquisition parameters and controls for moving the stage, the Data Collection window displays images as they are acquired, and the Filter Monitor displays the filters currently selected.



**Note** You will use the Resolve3D window throughout the data collection process. For more about this window, see “The Resolve3D Window” on Page E.1.

## Acquiring and Saving Data

To acquire an image of your sample:

- Set up *DeltaVision* by placing the sample slide on the stage and selecting the appropriate filters.
- Find the sample so that it is visible in the eyepieces.
- Set the *DeltaVision* microscope to Camera mode.
- Acquire an image with the camera.

## Setting Up the Sample for Image Acquisition

Setting up *DeltaVision* for imaging includes placing the sample on the stage and selecting the appropriate filter set for the fluorescent probe used to label your sample.



### To prepare for image acquisition:



**Note** This procedure assumes you are using an oil immersion lens. If you're using a water, air, or silicone lens, you may need to modify this process accordingly.



1. If your system includes a xenon lamp for its primary light source, turn it on now. Otherwise, go directly to Step 2.
2. Rotate the Coarse Focus knob to move the objective all the way down. (While sitting in front of the microscope, you'll rotate the knob so that the top of the knob rotates away from you.)
3. Rotate the objective turret (using the thumb wheel located at the left-underside of the stage) to select an objective.

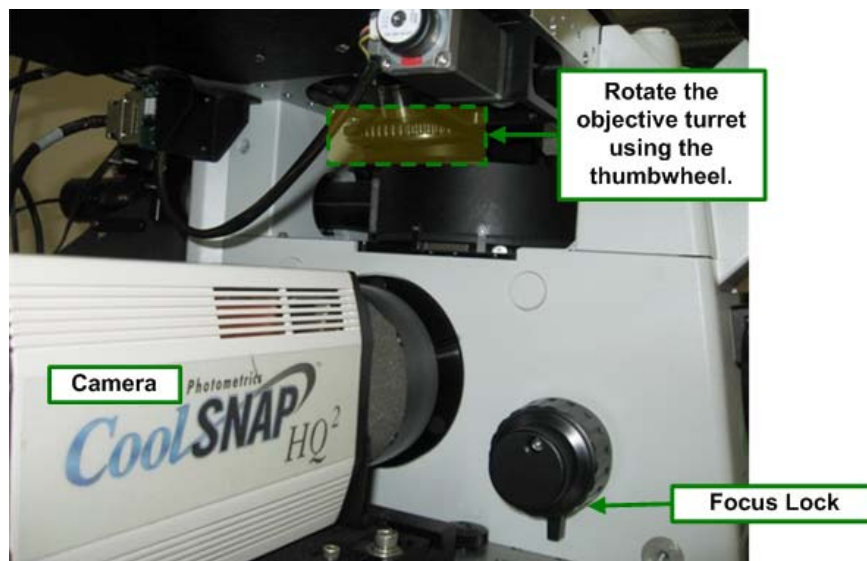
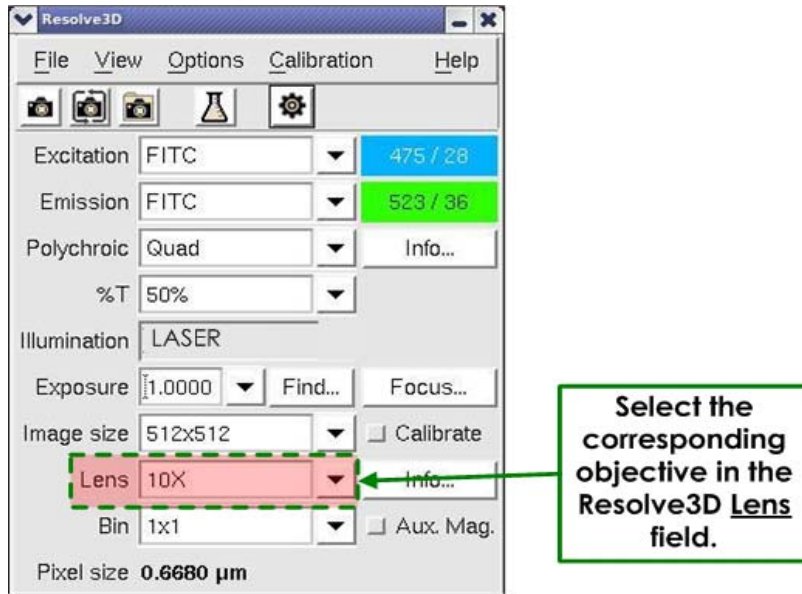

Figure 3.4 Adjust the objective turret beneath the left side of the stage to select an objective.

4. In the Resolve3D Lens list, select the matching objective.



Select the corresponding objective in the Resolve3D Lens field.



**CAUTION!** Make sure that the correct objective is selected in the Resolve3D Lens list.

5. Rotate the polychroic filter wheel (located on the right-underside of the stage) to select the appropriate dichroic mirror.



**Note** If your DeltaVision Imaging System is equipped with a motorized polychroic turret, you will control the turret's position using the *softWoRx* software.



Figure 3.5 Polychroic filter wheel control

6. In the Resolve3D Window, click the **Info** button next to the **Lens** field to open the Lens Information window.

Lens Information	
Lens ID	10105
Name	Olympus 10X/0.40, D Plan Apo UV, phase, fluor fr
Manufacturer	Olympus
Manufacturer P/N	1-LP331
APLLC P/N	Unknown
Magnification	10.0
NA	0.40
Working Distance (μm)	3100.0
Focal Length (μm)	15690.0
Standard Refractive Index	1.000
Recommended Refractive Index	1.000
Optical Conditions	
Distance From Coverslip to Specimen (μm)	0.0
Coverslip Thickness (μm)	170.0
Temperature (C)	25.0
Specimen Refractive Index	1.470
	1.470 - Pure Glycerol
Resolution Calculations	
Resolution Ratio (Z/XY)	9.2
Depth of Field (μm)	3.16
Maximum XY Pixel Size (μm)	0.48
Recommended Z Step Size (μm)	4.35

7. In the **Optical Conditions** fields, enter the conditions for the sample.
8. If you're using an oil immersion lens, note the displayed value in the **Recommended Refractive Index** field and apply an oil with that refractive index. See Page A.1 for details.



**CAUTION!** Before you start each data collection session, calculate the oil. Your oil selection should be the same if the sample and conditions are the same.



**CAUTION!** Do not touch the glass dropper to the objective.

9. Mount the slide on the stage with the coverslip down.
10. If installed, use the Adjustment knob on the Repeatable Slide Holder and the joystick on the Keypad to center the coverslip over the objective.



**Tip** If you have the Repeatable Slide Holder, you can record the position of your slide. This is useful when you are performing a Point Visiting experiment and you need to remove the slide before you are finished with the experiment.

11. Rotate the Coarse Focus knob toward you to move the objective up until the coverslip is just in contact with the oil. From this point on, use only the fine focus knob to raise and lower the objective.



**Note** If your DeltaVision system includes the UltimateFocus Module, you can use alternate methods for finding the focal plane.

12. Rotate the eyepiece filter wheel (below the oculars on the scope) to select the filter for the probe used to stain your sample. If your sample has more than one probe, select the one with the brightest fluorescence. The selected filter is displayed on the Filter Monitor window.



Figure 3.6 Filter Monitor Window

The filter names are displayed in the Filter Monitor window on the right side of the workstation screen. As you rotate the eyepiece filter wheel, the filter name next to **EP** (eyepiece) changes and the **EM** and **EX** (emission and excitation) filters change automatically to match.

The displayed colors match the wavelengths of the installed filters. If an X4 Laser Module is installed, the Filter Monitor also displays the wavelengths of the lasers that are available on your system.

To determine the probes to use with each filter and the EX and EM wavelengths for each, refer to *Standard Fluorescence Filters* in Appendix D: Reference Information (Page D.2).

#### To find the sample:

1. With the sample on the stage and the filters selected (shown in the previous procedure), set the Port Selector to **Eyepiece**. 
2. Turn off the lights in the lab. If you cannot turn off the lights, place a box over the sample to reduce the amount of ambient light.



3. Open the Excitation shutter by pressing the EX SHUTTER button in the lower left corner of the keypad.

You should see light through the objective. The light on the stage should be the same color as the Excitation filter that you selected. (For example, if you selected DAPI, the light should be very deep violet. It may be hard to see.) Be sure the eyepiece filter position matches the desired excitation filter position.



**Note** The Excitation shutter is designed to protect your eyes. Each time the eyepiece filter wheel position is changed, the shutter automatically closes and must be reopened with the EX SHUTTER button.

4. Focus to find the focal plane. Turn the Fine Focus knob toward you to slowly raise the objective until you see a cloud of emission color in the eyepiece. Continue to slowly raise the objective until the sample image is sharp and clear.
5. Use the joystick to move the stage around. Change the speed of the movement with the SLOW, MEDIUM, and FAST keys on the Keypad. When you find a region of interest, place it in the middle of the field of view.

On the Stage View, note the stage trails that show where you have moved the stage in XY.

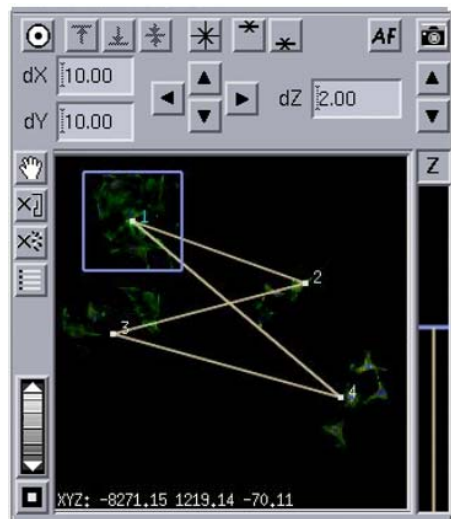



Figure 3.7 Stage Trails in the Stage View Window

## Acquiring an Image

To acquire a *DeltaVision* image, you'll need to set the port selector to **Camera**  and work with the images that are displayed in the Data Collection window until you are satisfied. Then you can create and run experiments, as described in "Setting Up and Running Experiments" on Page 4.1.

### To acquire an image:

1. On the keypad, press **EX Shutter** to close the shutter.
2. Switch the Port Selector to **Camera**.
3. In the Resolve3D window **Exposure** field, enter an exposure time (in seconds). A good starting exposure time is 0.1 second for fixed cell and 0.01 seconds for live cell applications.



**Tip** You can also click the **Find** button on the Resolve3D window to find a good exposure time. Use **Find** carefully. Overuse of this option can photobleach the specimen. **Find** is not recommended for use with live cell imaging.

- Click  to acquire an image.



**Tip** You can also acquire an image by pressing the ACQUIRE IMAGE button on the keypad, right-clicking on the stage view, and selecting **Acquire**; or by choosing **File | Acquire Image** on the Resolve3D menu.

- To focus, use the mouse to slide the Stage Z Control bar up or down.

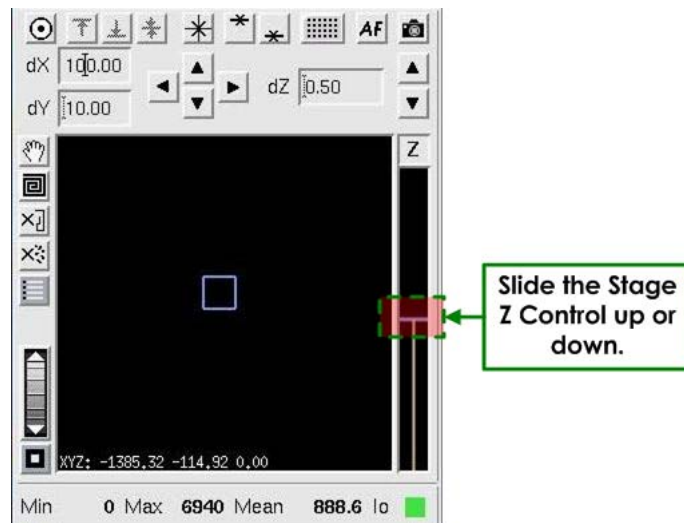

**Tip** You can also use software AutoFocus to focus the sample as follows: On the Resolve3D window, click **AF** to auto focus the sample. If your image is far out of focus, you may need to click **AF** more than once. Software AutoFocus is not recommended for live cell applications.

- To center the image, click  (above the Stage View window) and then click on the object that you want to center in the Image window.
- To enlarge the thumbnail image displayed in the Stage View, drag the mouse down over the zoom wheel.

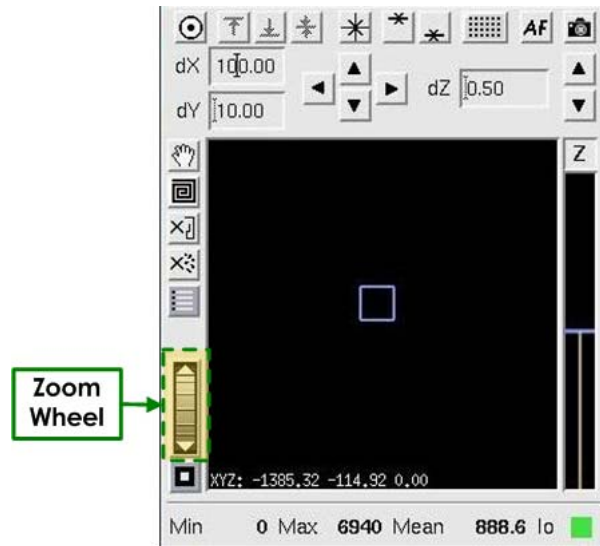

**Note** Thumbnails appear only when the **Show Stage Thumbnails** option is selected on the Misc tab in the Resolve3D Settings window.

- To clear the thumbnail image, click **Clear Thumbnails**  button next to the Stage View window.

## Saving Image Data

After you acquire an image, use these instructions to set up a personal data folder and use the Snapshot utility to acquire a single multi-channel image.

### Setting up a Personal Data Folder

You can set up a personal data folder in which to save your images. After you create and save this folder, *DeltaVision* automatically uses it as the data folder when you log on to the system.

#### To set up a personal data folder:

- At the top of the Resolve3D window, click the **Settings** icon to open the **Resolve3D Settings** window. Then click the **Files** tab.

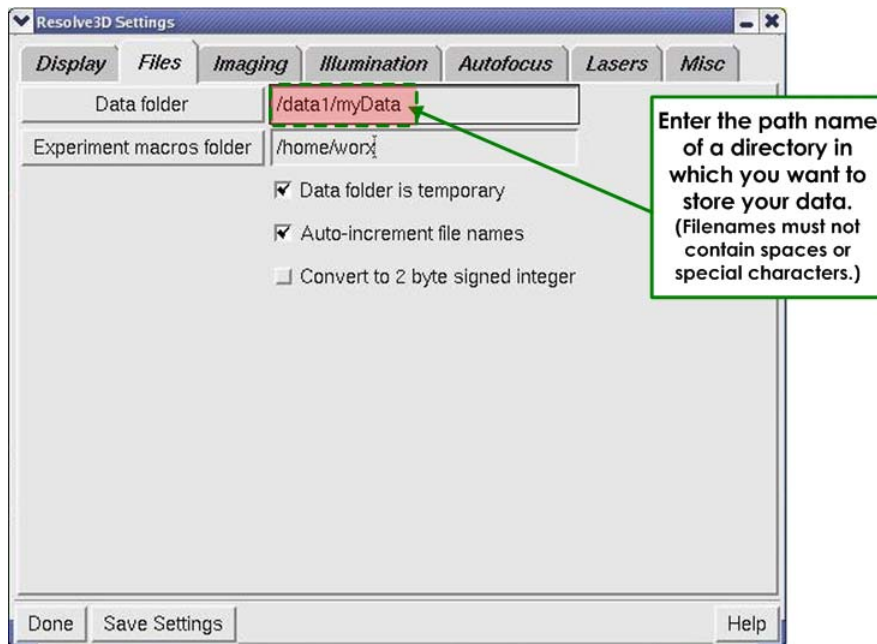

- In the **Data folder** field, enter the directory (e.g., `/data1/myData`) in which you want to save your images. To create a new folder, type the name of the folder after `/data1` (e.g., `/data1/myNewData`) and select **Save Settings**.



**Important** Store all files under the `/data1` directory unless you are instructed to do otherwise by your system administrator. If you store files outside the `/data1` directory on the workstation, you can render the system unusable.



**Tip** If you are using an existing folder for your data, you can drag and drop the folder from the Linux File Manager to the **Data folder** field.

- To reset the default Data folder when you log out, select the **Data folder is temporary** option.

## Saving a Single-Section, Multi-Channel Image

Sometimes it is desirable to acquire a single-section, multi-channel image. The Snapshot utility helps you quickly create a 2-D, multi-wavelength image without having to run a full experiment.

### To acquire a Single-section, Multi-channel image:

- From the Resolve3D window tool bar, click the **Snapshot** icon to open the Resolve3D Snapshot window.



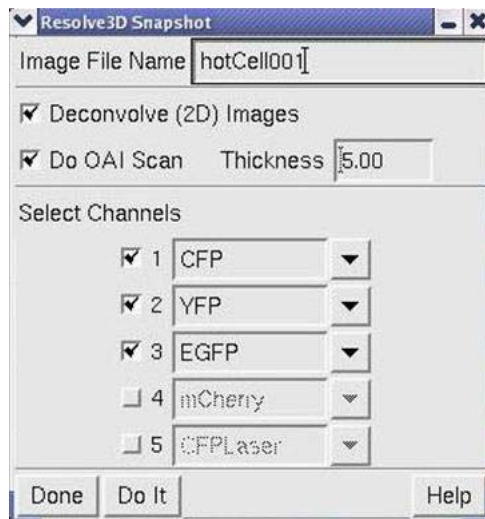

Figure 3.8 Resolve3D Snapshot Window



**Tip** Alternatively, you can open the Resolve3D Snapshot window by right-clicking on the Resolve3D window and choosing **Snapshot** from the shortcut menu.

- In the **Image File Name** field, enter a file name. Then select which channels to save. (Snapshot uses the exposure conditions that were last used in the Resolve3D window for those channels.)



**Note** *softWoRx* adds the `_R3D.dv` extension to the file name. If you enter a file name without a directory path, the file will be located in the current data folder. You can specify to place the file in another directory by including the path in the file name (e.g., `/data1/myFolder/myfile`).



- Click **Do It**.

An image window opens and displays the new image. The image is saved as a *DeltaVision* file that you can open in *softWoRx*.

## Turning DeltaVision Off

Use the following instructions to turn off *DeltaVision* on a daily basis. For instructions that show how to shut down the system, see “Shutting Down the System” on Page 10.3.

### To turn off *DeltaVision*:

- If your light source is the xenon arc lamp, turn off the lamp using the bulb  icon on the Resolve3D window. Clicking the icon switches it to the **off**  state.



**Note** If you are using InsightSSI for your main light source, skip this step and continue to Step 2.

---

2. Save all data on the workstation.
  3. On the *softWoRx* menu bar, select **File | Exit**. Then exit all other workstation applications.
  4. Log out of the workstation account.
  5. Press the IC/MIC power switch to turn off the IC/MIC. Wait 30 – 60 seconds for the IC/ MIC to power down.
- 



**Note** If the IC/MIC fails to turn off within 30 – 60 seconds after pressing the power switch, contact your system administrator.

---

6. Turn off any additional equipment such as cameras or the heater for the environmental chamber.
  7. Dab the objective with a clean, unused cotton swab or lens paper to remove all of the oil on the objective. Then apply chloroform to a cotton swab, gently roll it over the objective lens once, and discard it.
- 



**CAUTION:** After you finish imaging, always clean the objective with a clean, unused swab or lens paper. Never reuse swabs or lens paper.

---

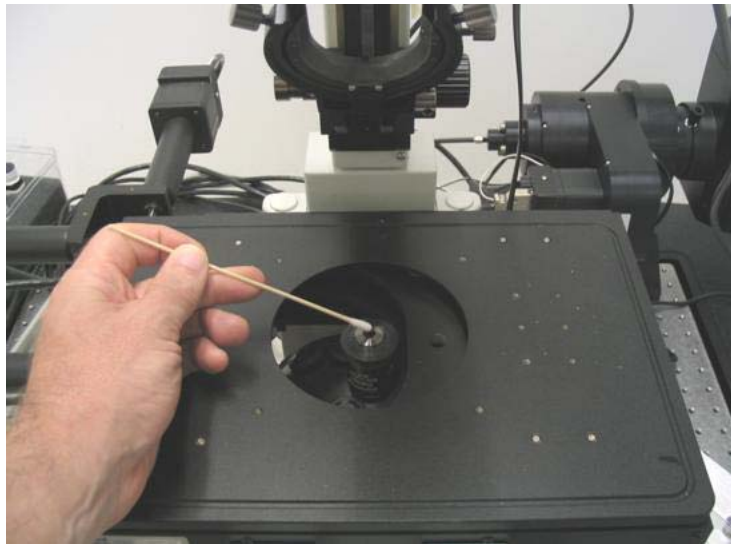

**WARNING!** Chloroform is a hazardous substance. Use caution when handling this chemical and adhere to the recommendations listed in the Material Safety Data Sheet (MSDS) for this substance.

---

- Lower the objective by turning the Coarse Z Focus knob away from you when facing the knob (clockwise on the right-side knob).



**WARNING!** If any liquid, including immersion oil, is spilled on or around the instrument, unplug the instrument immediately and clean up the spill completely. **DO NOT PLUG THE INSTRUMENT INTO ANY POWER MAINS UNTIL THE PROBLEM IS RESOLVED.**

---



## 4. Setting Up and Running Experiments

---

A *DeltaVision* experiment is a macro that runs a set of instructions for collecting image data. You will use experiments to acquire almost all of your data. This chapter shows how to set up and run experiments that use several *DeltaVision* data collection options, including:

- Creating and Running an Experiment Macro
- Sectioning Specimens for 3D Images
- Setting Up Time-lapse Experiments
- Point Visiting
- Collecting Panel Images Over Large Areas

### Creating and Running an Experiment Macro

Resolve3D Experiment macros are files that include settings and commands for acquiring data with *DeltaVision*. Macros allow you to automate data collection. After you use the Resolve3D interface to create a macro, you can run the macro to collect data. Macros can be very simple or they can be very complex and include numerous options. After you create a macro, you can use it as a template to modify and create other macros.

**To create and run an experiment macro:**

1. At the top of the Resolve3D window, click the **Experiment** button to open the Design/Run Experiment window.
2. Click the **Design** tab.

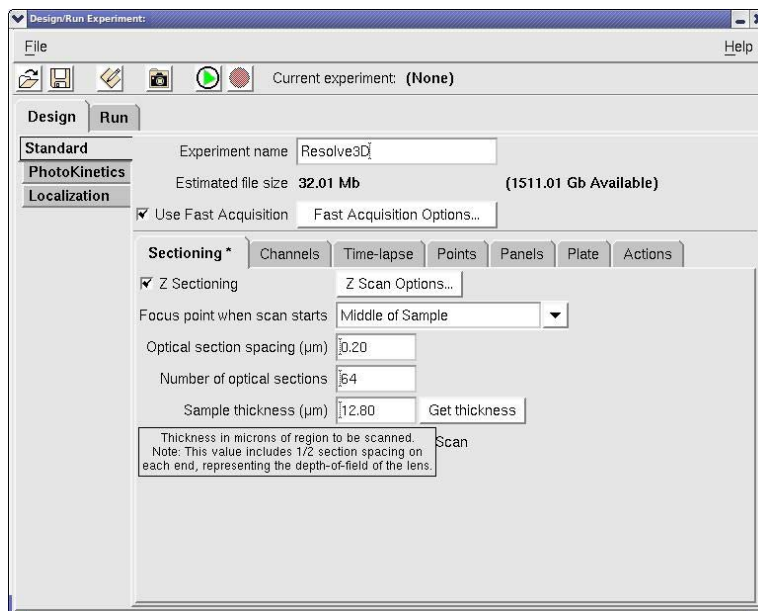

3. In the **Experiment name** field, enter a name for the macro only if you need to have it saved as a unique macro. By default, *softWoRx* uses *Resolve3D* as the experiment name. If you do not intend to reuse an experiment, using *Resolve3D* for the experiment name is the recommended method.
4. From the top of the Design/Run Experiment window, click the **Save**  icon. The macro name appears in the Design/Run Experiment window title bar.
5. Click the **Run** tab.

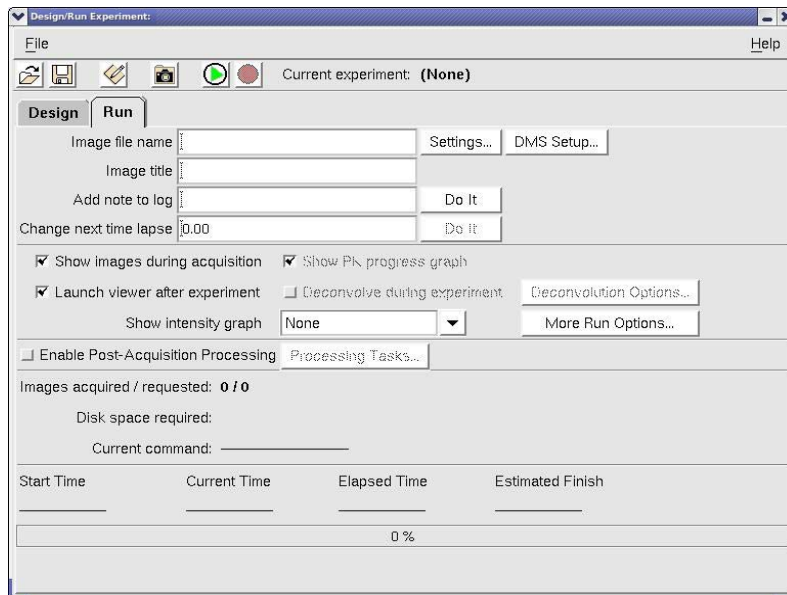

6. In the **Image file name** field, enter the file name.

**Notes**

#1 Files names can include alpha-numeric, dash, and underscore characters.

#2 The resulting image file name has an \_R3D.dv extension. This is the unprocessed (i.e., raw) Resolve3D image. A file with a .log extension is also created. The .log file is a text file containing information about the image file, including the macro and objective that were used to collect the image.

7. In the tool bar at the top of the screen, click the green arrow button  to start the scan.

The macro collects the image and saves it in your data folder (see *Setting Up a Personal Data Folder* on Page 3.17). To process the image, use the *softWoRx* program, as described in the *softWoRx Imaging Workstation User's Manual*.

## Sectioning Specimens for 3D Images

Using the *DeltaVision* system's precision XYZ stages, you can acquire images of multiple sections. This type of data can be used to create 3D projections, view cross sections, and create volumetric and line models.

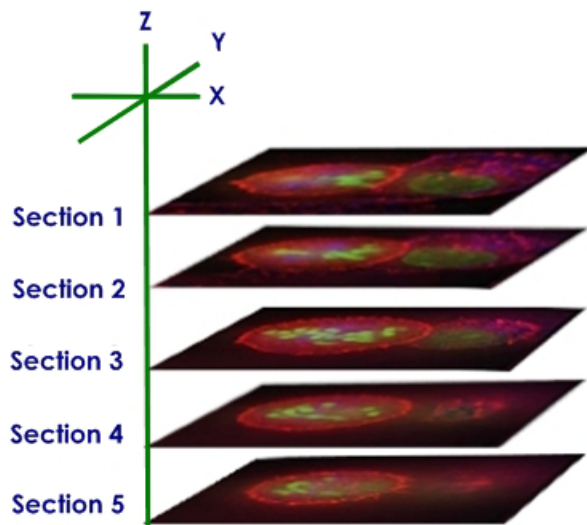

If you are new to 3D microscopy, you may have never had to deal with the specimen's absolute three-dimensional size (except in relation to the rest of the specimen). Manually operated microscopes provide very little information about absolute distances in Z, or even X and Y. Once you start viewing your specimens in three-dimensions, however, you will become accustomed to the relationship between the microscope stage, sample, and optics, and will find that designing a 3D experiment is usually straightforward.

When you set up a Z sectioning (3D) experiment on *DeltaVision*, you normally begin by defining a Z range (or scanning thickness) to use. You start by finding a central plane of interest within the sample. The sectioning scan range is then defined by finding and

marking the top and bottom of the sample. The target specimen data is captured by acquiring images at different Z planes within the defined scan range.

Use the following procedure to create and run a 3D experiment. To determine the Focus point when scan starts, Optical section spacing, Number of optical sections, and Sample thickness, refer to Guidelines for Designing/Running 3D Experiments on Page 4.6.



**Note** The softWoRx software reports all distances in microns.

---

#### To design and run a 3D experiment:



1. You'll need to set the proper exposure for each channel you plan to image. In the Resolve3D window, use the blue Z Slider on the right side of the Resolve3D window to find and focus the object of interest. Select your primary channel of interest and find its focal plane. This plane tends to provide an image with the highest Max Counts value.
2. Adjust the %T and exposure time until the Max Counts is ~50-60% of the camera saturation value for fixed samples and 2-3 times the minimum value for live cells.



**Tip** Generally shorter EX times with higher %T is preferred over long EX times with lower %T.

---

Repeat the process of finding the exposure time and %T for each active channel.

3. Select the filters that correspond to the fluorophore that occupies the greatest volume of your sample.
4. Drag the Z Slider in the Resolve3D window up to find the top of your sample. (When the mouse button is pressed, the line turns red. When you release the mouse button, an image is acquired and displayed in the Data Collection window.) Drag the slider or use the Z arrows and acquire images until you are satisfied with the position. Then press the **Mark Top**  button to mark that location. Next, use the slider to find the bottom of the sample. When you are satisfied, press the **Mark Bottom**  button to mark that location. The region between the top and bottom marks becomes shaded and the represented thickness is used when running the experiment.



**Note** To reduce the risk of running the objective lens into the sample, the Z slider is limited to 5  $\mu\text{m}$  steps at a time.

---



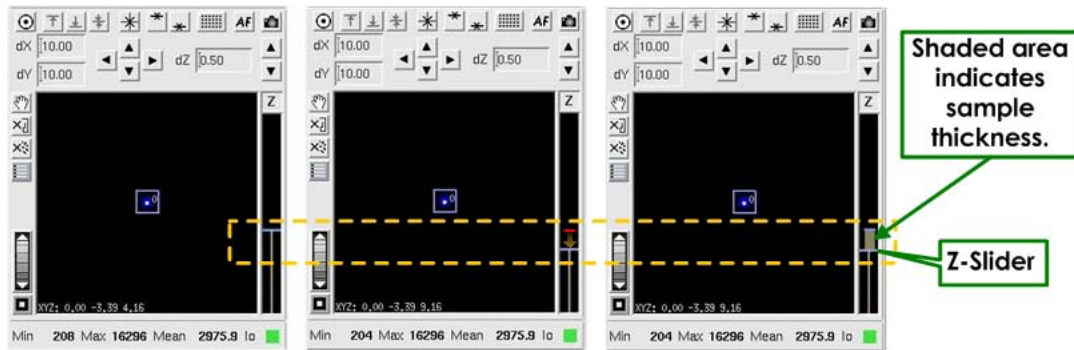

Use the Z slider to find the top and bottom of a sample. The sample thickness is indicated by the shaded area on the Z slider (shown in the image on the right).



**Note** The Z stage view displays the relative position of the objective lens to the sample for an inverted microscope. Dragging the Z slider down focuses the microscope closer to the cover glass (negative direction). Dragging the Z slider up moves the focus from the cover glass toward the microscope slide (positive direction).

- Click **Experiment** to open the Design/Run Experiment window and click the **Design** tab. Then click the **Standard** and **Sectioning** tabs.

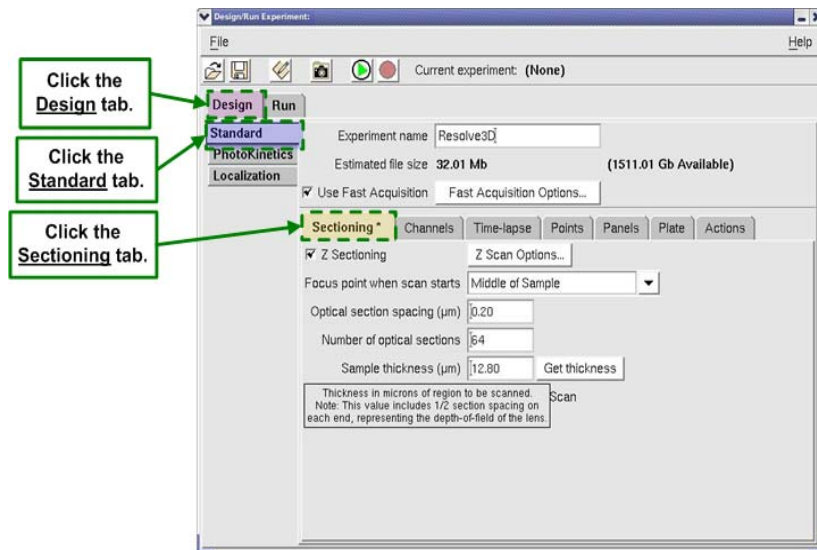

- Specify the focus point of the microscope at the start of the experiment and move the stage to that focus point as follows:

Choose one of the following focus points in the Focus point when scan starts list.	Then click the corresponding button in the Resolve3D window to move the stage to that focus point
Top of the sample	
Middle of the sample	
Bottom of the sample	



---

**CAUTION!** Be sure to set the focus consistently with this setting before you start the experiment. (For example, if you specify to use the **Middle of Sample** option, be sure to focus midway between the top and bottom of the sample.) *DeltaVision* generates the sectioning commands based on this relative starting point. If this is not done correctly, you may not capture the desired data.

---

7. Specify the separation (in microns) between each optical section in the **Optical section spacing** field. If you are using a 60X objective, start by using the default value (.2  $\mu\text{m}$ ). If you are using another objective, click the **Info** button (next to the **Lens** field) on the Resolve3D window to open the Lens Information window. Use the value in the **Recommended Z Step Size** field (at the bottom of the window). As a general rule of thumb, the Z step size is approximately 1/3 of the Z resolution for each objective.
8. Specify the number of sections and the sample thickness as follows:
  - To specify the number of sections, enter the number of sections in the **Number of optical sections** field.
  - To get the thickness of the specimen, as defined in Step 2, click **Get thickness**. *softWoRx* adjusts the number of sections to span the specimen thickness.
9. Save and run the experiment.

## Guidelines for Designing/Running 3D Experiments

Use the following guidelines to determine values for the fields on the Sectioning tab under the Design/Run Experiment window > Design Experiment tab.

### Focus point when scan starts

The **Focus point when scan starts** field allows you to specify the focal plane of the microscope stage at the start of an experiment.

Choose one of the following options:

- **Middle of Sample** (Middle Focal Plane) – The focal plane is midway between the top and bottom of the sample. This is the default and is usually the "plane of best focus" for the sample. This is also the best point to set for Point Visiting.
- **Bottom of Sample** (Top Focal Plane) – This represents a plane where the sample is farthest away from the objective.
- **Top of Sample** (Bottom Focal Plane) – This represents a plane where the sample is closest to the objective.

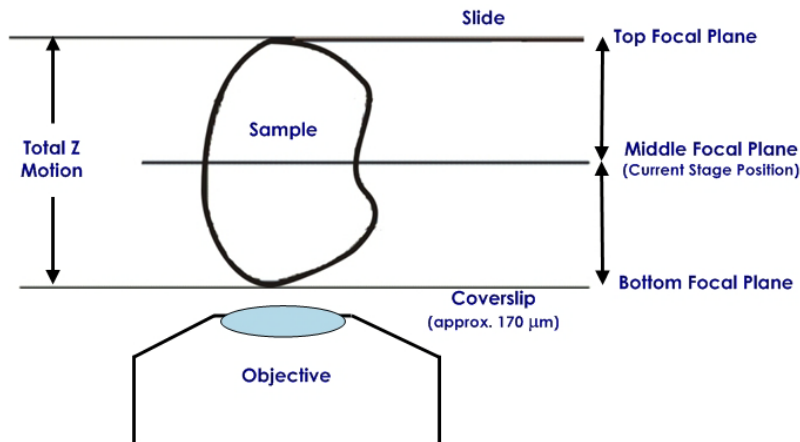

## Optical section spacing

The **Optical section spacing** field indirectly defines the size of the incremental Z stage movement (the distance between focal planes).

When *DeltaVision* acquires an image, the objective collects information within the depth of field above and below the focal plane.

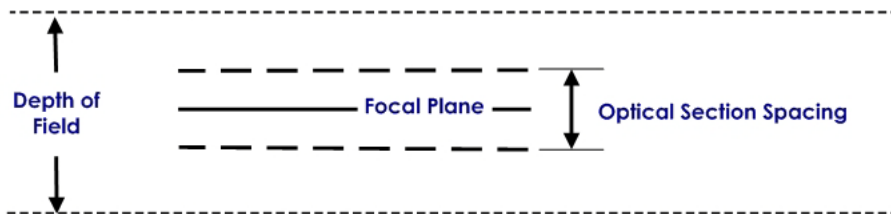

The Optical section spacing specifies the upper and lower boundaries for which information is collected. It is centered on the focal plane and includes the information above and below that plane.

When you select an Optical section spacing, *DeltaVision* uses a Z step size that is the same distance as the Optical section spacing. (The Z step size is the vertical distance that the stage moves between focal planes.)

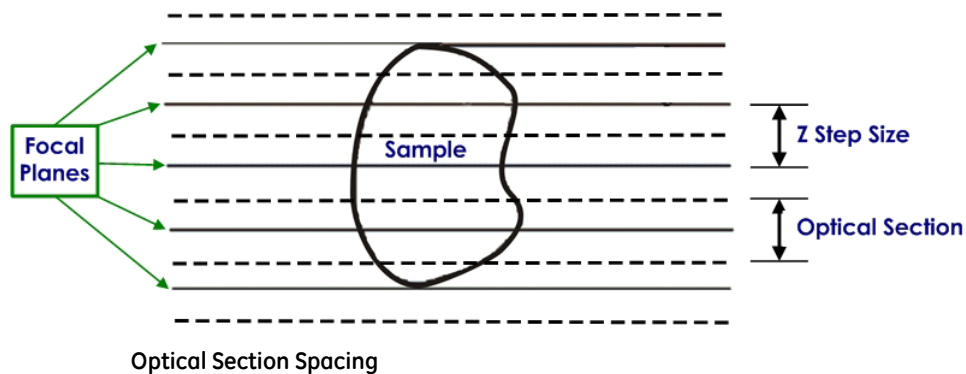

For example, the standard step size for a 1.42 NA lens is 0.2  $\mu\text{m}$ , although other step sizes are usually fine. Due to the inherent Z resolution of a 1.42 NA lens, there is little need to take steps finer than 0.1  $\mu\text{m}$ .

When scanning a PSF (see *Appendix C* on Page C.1), use 0.1  $\mu\text{m}$  steps. For low power lenses, the step size should be appropriately larger. The Lens Info window for each lens contains the suggested Z Step size for each lens (derived using Nyquist sampling). This value is approximately 1/3 of the theoretical Z resolution for each objective.

## Number of optical sections

The **Number of optical sections** field defines the number of optical sections in the Z series of the experiment. Enter the number of sections necessary to span from the lower to the upper boundaries of the sample.

The required number of Z sections depends upon the thickness of your specimen. A typical scan consists of between 16 and 64 sections, but there is no set number. For best results, use at least three optical sections. Using one or two optical sections, however, will also provide acceptable results.

The maximum number of optical sections is limited by memory and time. GE's benchmark deconvolution consists of 64 optical sections that have XY dimensions of 512x512.

## Sample thickness

The **Sample thickness** field displays the thickness of the optical section range. It is approximately one section thicker than the actual stage movement, as shown below.

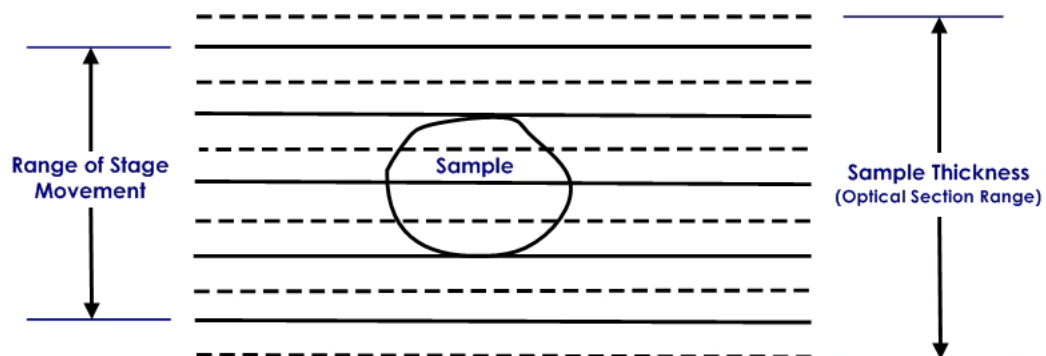

For optimal deconvolution, the Z sections should extend beyond the volume of interest by 1-3 sections.

$$\text{Sample thickness} = \text{Optical section spacing} \times \text{Number of optical sections}$$

A number of methods have been used to determine the necessary Z scan settings. There is not really a single best way to approach the problem. The best method for your work depends largely on preference and experience.

## Selecting Filters

Channels define which wavelengths and filters are used. From the **Channels** tab on the **Design Experiment** tab in the Design/Run Experiment window, you can define which filter

sets to use in the experiment for imaging. *DeltaVision* acquires images from each selected filter set (channel) and creates a single *DeltaVision* file that contains all of the channels that were collected. There can be up to five channels per experiment.



FITC (left) and DAPI (center) filtered images are combined in the final *DeltaVision* file (right).

## Choosing Filters

Your choice of filters will be determined by the types of fluorescent probes with which you have labeled your sample and the filters available on your system. The excitation and emission spectrum of your filters should match the spectra for the absorption and emission of the fluorescent probes you want to use.

Some *DeltaVision* systems use interchangeable Standard and Live Cell filter modules. The Standard filter module filter sets are typically used for fixed specimens while the Live Cell filter module sets are commonly used for live specimens.

You can select other combinations of excitation and emission filters. You can also add your own custom filter sets. The spectra for the standard *DeltaVision* filter sets and the optional Live Cell sets are provided in *Appendix D* on Page D.1.



**Note** The CY-5 filter set does not include an eyepiece filter due to the low sensitivity of the human eye at this wavelength.

---

For instructions on how to change filter wheel modules and calibrate filter wheels, see *Changing Filter Wheel Modules* and *Calibrating the Filter Wheels* in Chapter 8.

### To specify which filters to use:

1. On the Design/Run Experiment window, click the **Design** tab. Then click the **Channels** tab.
2. Select a check box on the far left next to an **Exp** field. The **EX Filter** field controls which excitation wavelength will be used. The **%T** field attenuates the intensity of the excitation light. The **EM Filter** field controls which filter will be placed in the emission pathway between the microscope and the camera. The **EX Source** field specifies which light source to use for that channel.
3. On the **EX Filter** list for the same line as the check box you selected, use the drop-down list to select the excitation filter. Entries for the **EM Filter** field and the **%T** field are automatically specified. (*DeltaVision* specifies the most recent filters that were

selected for that filter set in the Resolve3D window. If no filters have been selected, *DeltaVision* specifies default filters for that filter set.)

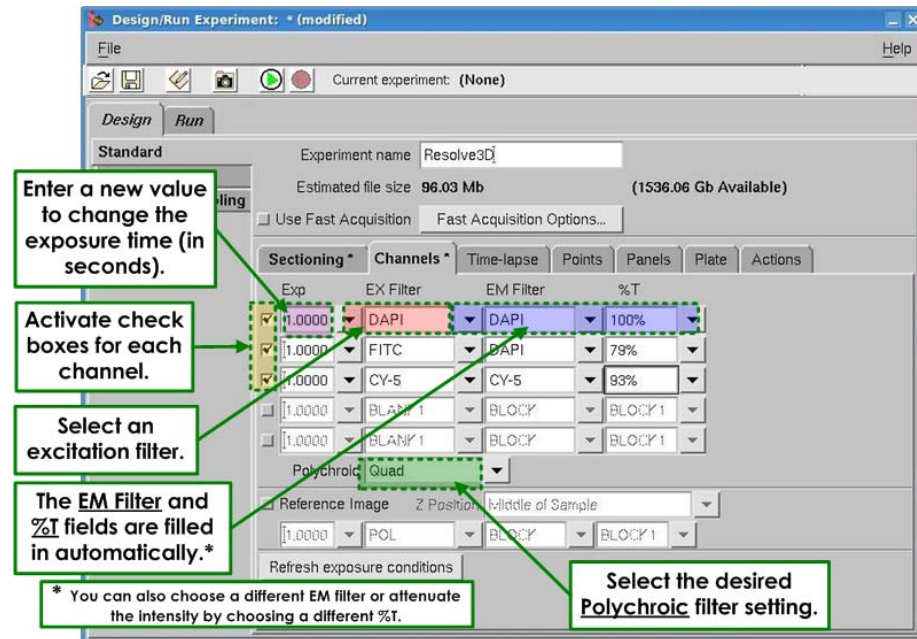

4. To change the exposure time, enter a value in the **Exp** field. Values in the **Exp** field are in seconds. For example, 0.100 is 1/10<sup>th</sup> of one second. If you do not enter a value from Resolve3D in this field, the most recently selected exposure value is automatically set for each filter.
5. To select a different emission filter, choose a filter from the **EM Filter** list.
6. To select a different neutral density setting to attenuate the intensity, choose a value from the **%T** list.
7. Repeat Steps 2-6 for each set of filters that you want to use.
8. In the **Polychroic** field, use the drop-down list to select the appropriate polychroic filter sets. (This field is available only when your *DeltaVision* system is equipped with a motorized polychroic turret.)
9. If you are repeating an experiment and you have entered new exposure times or %T in the Resolve3D window, click the **Refresh exposure conditions** button at the bottom of the window to update the chosen settings.
10. Save and run the experiment.

## Point Visiting

You can use point visiting to monitor areas of the slide that are in different fields of view. Instead of recording one cell or field in a single experiment, multiple sites can be imaged in a single experiment, increasing data collection efficiency.

In practice, the number of sites is limited only by the minimum acceptable time interval between each time point at a single site. This makes time-lapse imaging much more efficient, and allows you to collect enough data to generate statistically significant results.

In addition, variability between cells within an experiment can be assayed, eliminating uncertainty as to the behavior of cells in a single experiment.

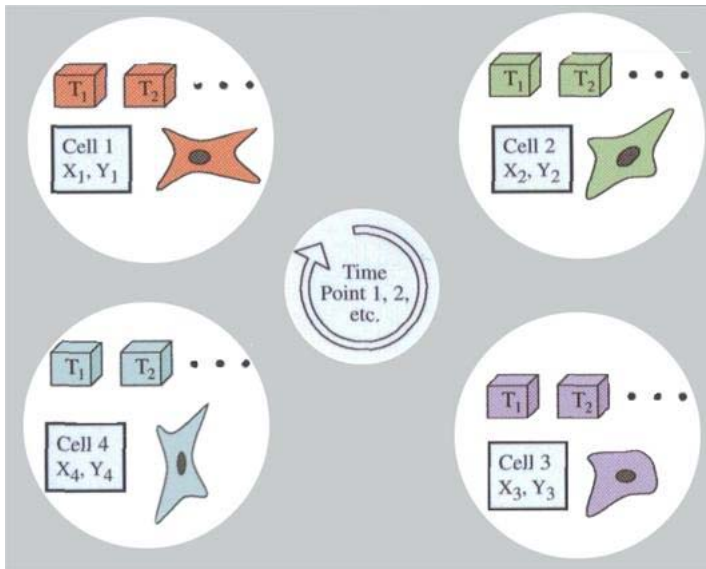

**Point Visiting monitors points that are in different fields of view.**

To set up an experiment that visits points:

- Mark the points to visit with the Keypad or with Resolve3D and save a point list if desired.
- Edit the point list if necessary.
- Load the point list and specify which points to visit.



### Notes

#1 If you are placing your slide directly on the microscope stage (without the Repeatable Slide Holder), you can store the X, Y, and Z coordinates of the stage positions you mark; however, if the slide is removed from the stage or the Z focus knob is adjusted, these coordinates no longer apply.

#2 If you are using the Repeatable Slide Holder, you can remove the slide and then place it in the same position when you want to revisit the points. To do this, you must record the Repeatable Slide Holder position (A-G) of the slide before you remove it. Then put the slide in the same position when you return it to the slide holder and update the Z coordinates.

---

## Marking Points

There are two ways to mark points within a sample: using the keypad or using Resolve3D. An efficient way to mark points is to use both methods together. First, mark the points using the keypad, which is quick and approximate, and save the point list. Then, in Resolve3D, specify a more exact location for each point.

The points marked using the keypad are automatically communicated to Resolve3D and displayed in the Stage view. You can view the list of points by opening the Point List window.

**To mark points using the keypad and Resolve3D:**

1. Use the arrows on the keypad or the joystick to move to the desired point.
2. Press the POINT MARK key on the keypad.

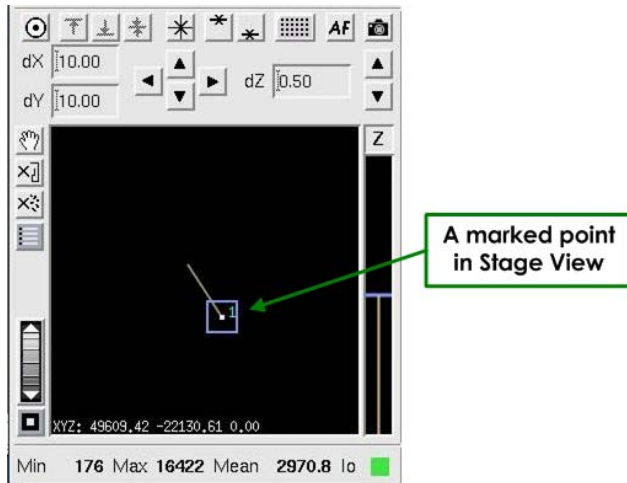

The number of the marked point is displayed in the Stage view.

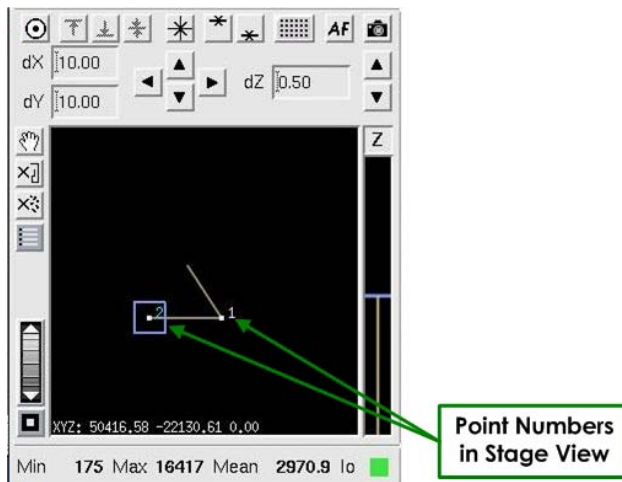

3. Repeat Steps 1 and 2 to mark multiple points.

As you mark points, the stage trails and points (along with their point numbers) are displayed in the Resolve3D Stage view.



4. To view all of the points, use the **Zoom Wheel** to zoom out on the Stage View. To pan the Stage View, use the **Pan**  button. Activate the **Pan** tool by clicking the **Pan** .



button and then dragging the image. To return to normal mode, press the **Pan**  button again.

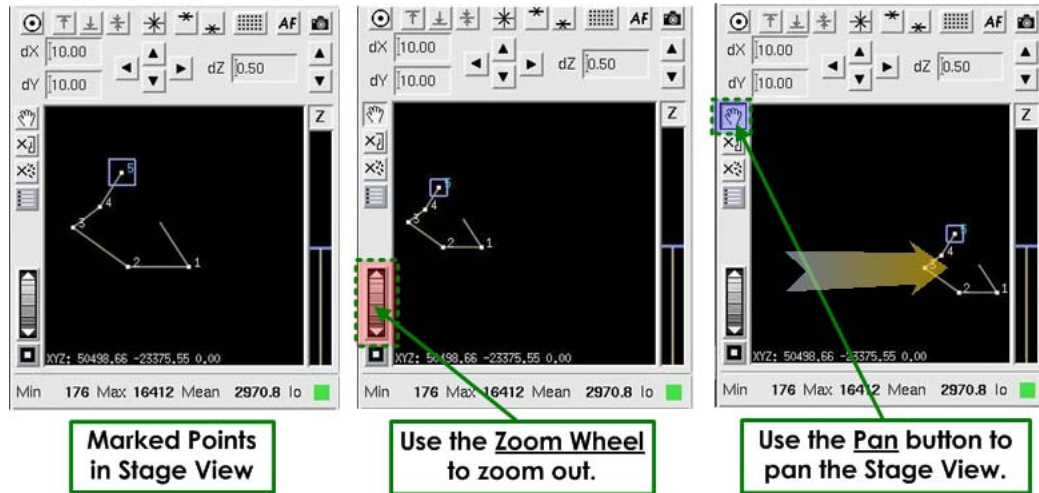

- In the Resolve3D window click the **Marked Point List**  icon to open the Point List window.

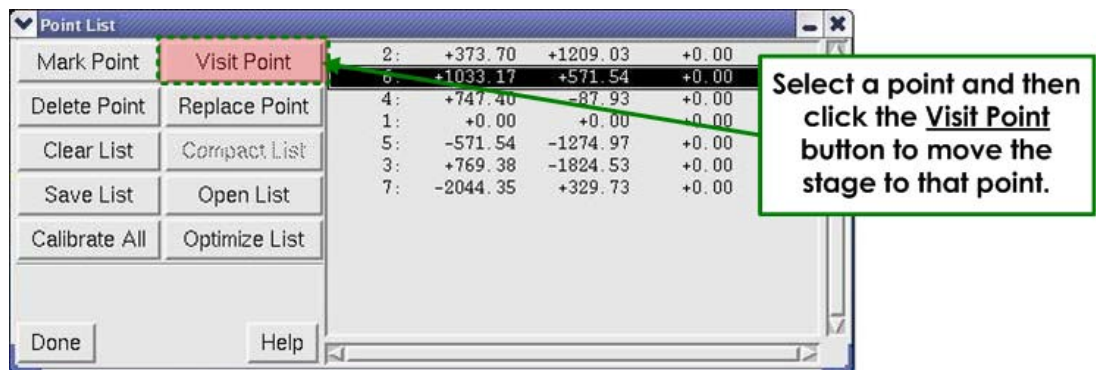

- From the Point List window, click on a point to select it and then click **Visit Point** to move the stage to that point.
- Use the XY Stage Controls on the Stage View to move the stage to refine the XY position using the camera.

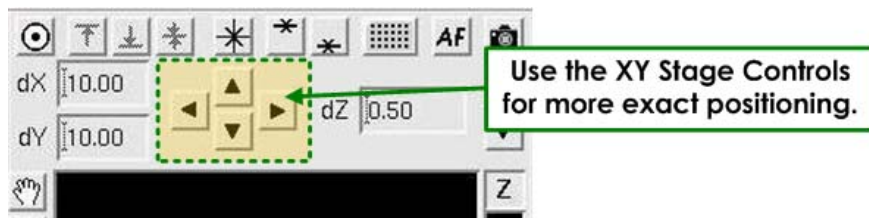

- Use the Resolve3D Z controls (the Z buttons or the Z slider on the Resolve3D window) or the **AF** (autofocus) button to find the focal plane.



**CAUTION!** To record and maintain accurate stage coordinates, focus by moving the stage with the Resolve3D controls instead of using the focus knobs to move the objective. Resolve3D cannot track the movement of the objective.

9. On the Point List window, click **Replace Point** to replace the old coordinates with the new exact coordinates for the point.
10. Repeat Steps 6-9 to replace all of the points in the list with the exact X, Y, and Z coordinates.

## Editing a Point List

To delete a point using Resolve3D:

1. In the Point List window, select the point that you want to delete.
2. Click **Delete Point**.

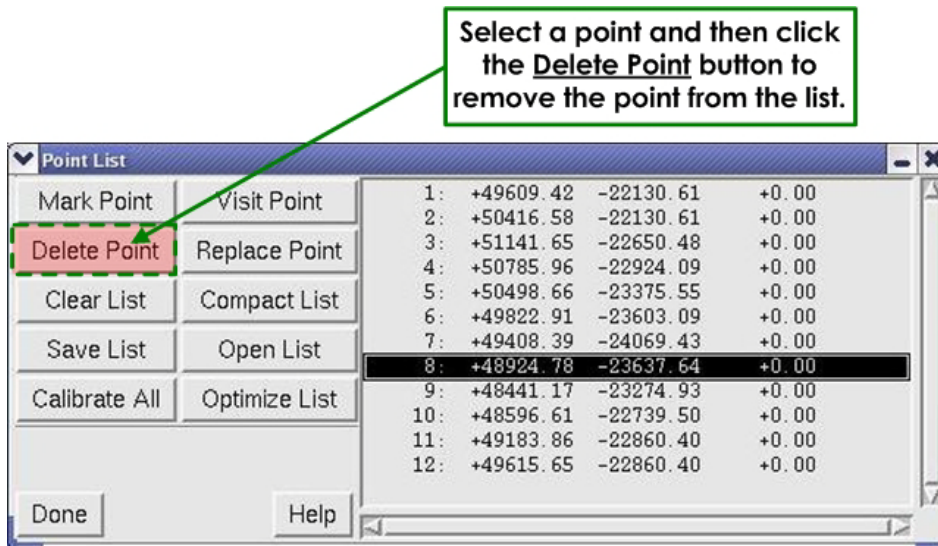

To save the point list:

1. In the Point List window, click the **Save List** button. The Save Point List File window is displayed.

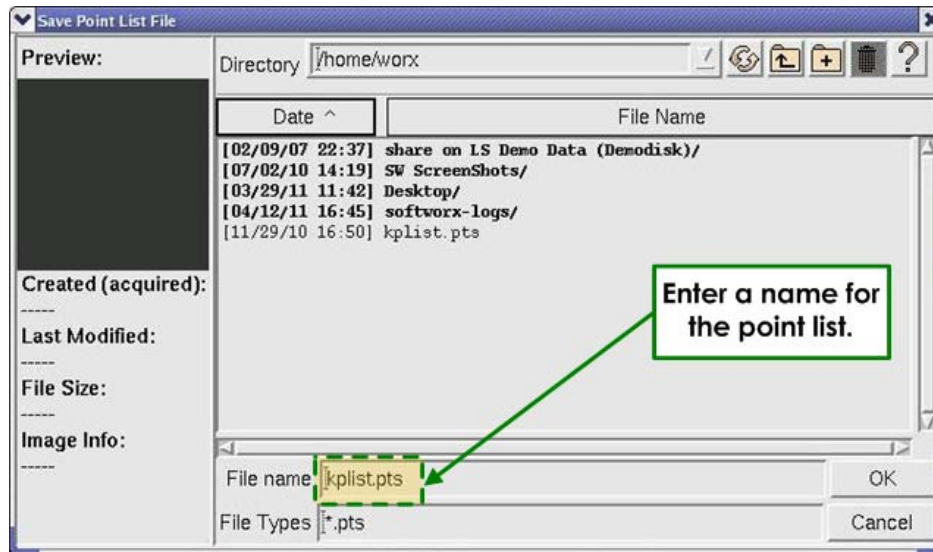

Save Point List File Window

- In the Prompt window, enter a name for the point list.
- Press the Enter key or click **OK**. The point list file will have a .pts extension.

#### To visit a point using Resolve3D:

Use one of the following methods to visit a point:

- In the Stage view, double-click on the point.
- In the Point List window, click the point that you want to visit and click the **Visit Point** button.

## Loading a Point List and Specifying Points to Visit

If you are using a previously saved point list, you will need to load the point list in Resolve3D before you specify which points to visit.



**Tip** You can mark and then visit a point list without saving it when you are setting up an experiment.

#### To load a point list into Resolve3D:

- On the Resolve3D window, click  or choose **View | Points List** to open the Point List window.

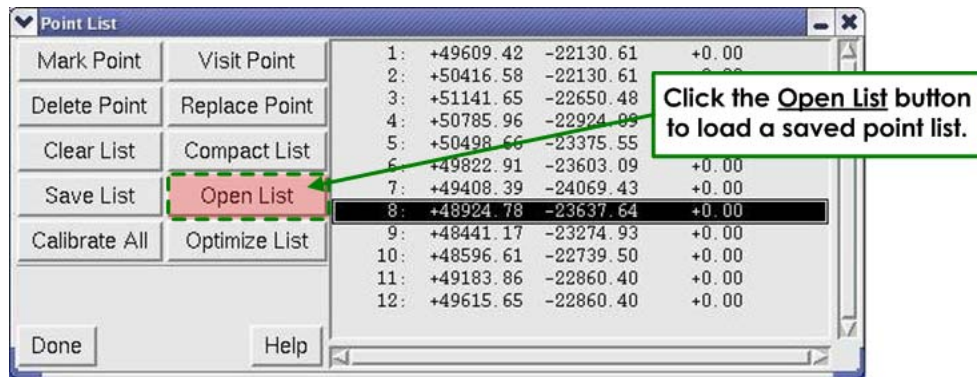

2. Click **Open List**. The Open Point List File window is displayed.

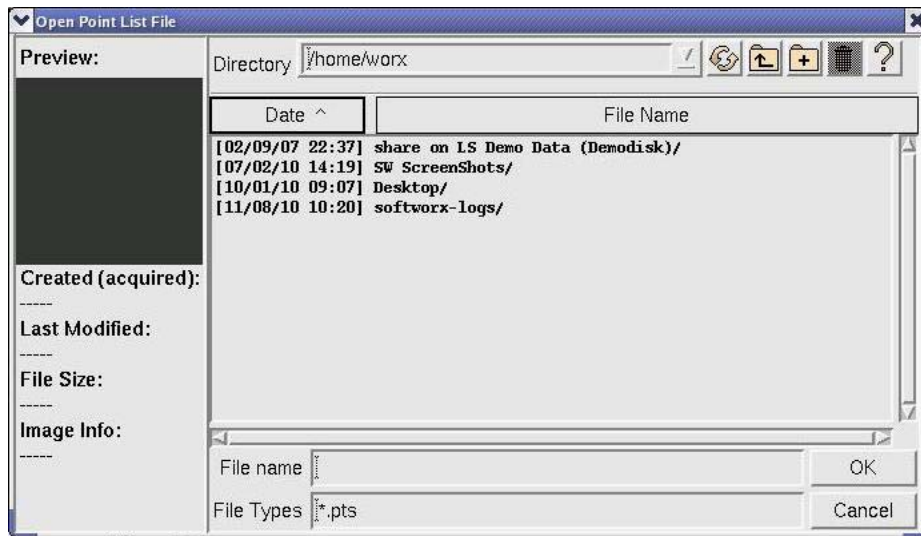

**Open Point List File Window**

3. In the **File name** field, select a file from the directory or enter a name for the list and click **OK**.



**Note** You may need to load a list when the list of points has been cleared from the Point List window and you want to reload the saved list.

#### To specify which points to visit:

1. Make sure that the point list is loaded in the Point List window.

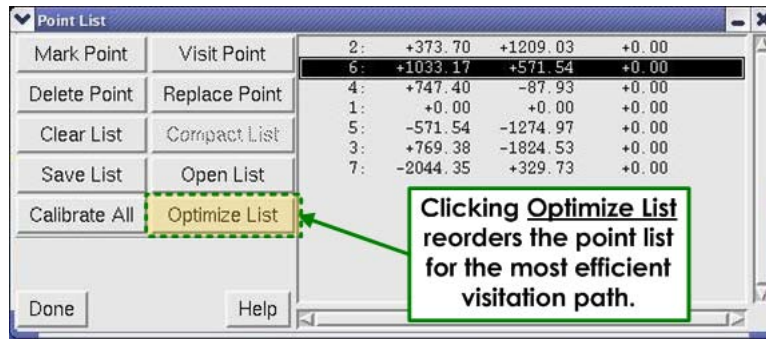

**Note** Click the **Optimize List** button to run an algorithm that determines the fastest route through all of the selected points, beginning with the currently selected point. The sequence of points in the list is reordered accordingly. (In the example above, Point #2 was selected as the starting point.)

- Open the Design/Run Experiment window and click the **Design** tab. Then click the **Points** tab and activate the **Visit Point List** check box.

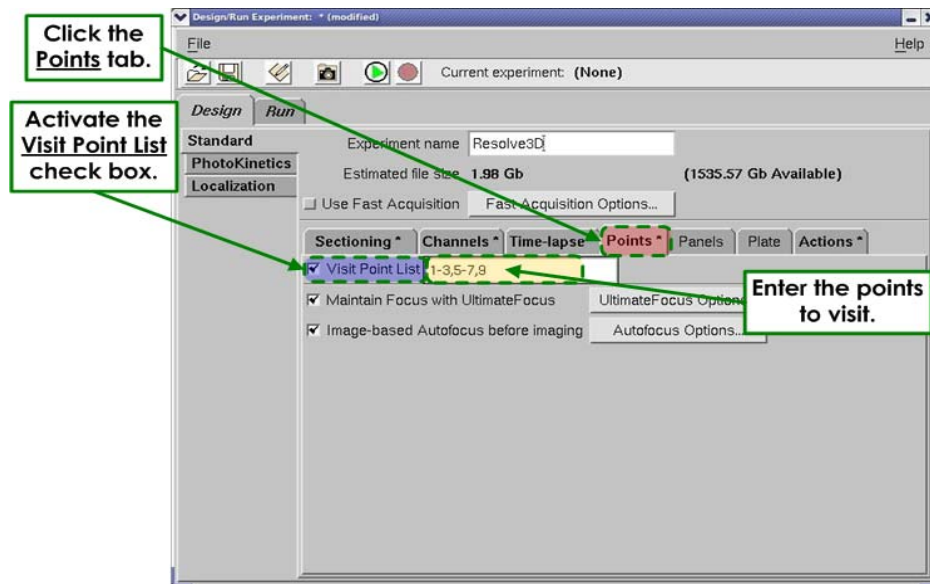

The Point Visiting window is linked to the point list that is open.

- Enter the points that you would like to visit in the **Visit Point List** field (to the right of the **Visit Point List** check box). For example, entering 1-3 specifies to visit the first 3 points in the point list. Entering 1-3, 5-7, 9 specifies to visit Points 1-9, but not 4 or 8.



**Note** It's important to note that the point names do not really reflect their position within the list. The values you enter into this field represent the point positions in the list, not necessarily the displayed names. (For example, if your list has point names of 1, 3, 7, 8 and you enter 2, 4 into the field, the experiment would visit point names 3 & 8.)

## Monitoring Point Visiting Experiments with Point Track

You can set up DeltaVision to display a separate Data Collection window for each point in your point visiting experiment.

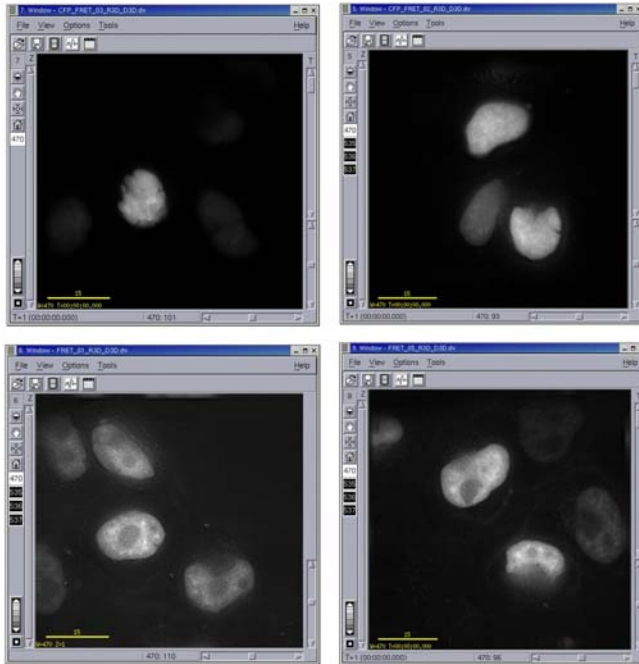

With the Point Track Display Option enabled, each point in a point visiting experiment is displayed in a separate window.

### To set the Point Track display option:

1. On the Resolve3D window, click the **Settings** icon to open the Resolve3D Settings window.
2. Click the **Display** tab.

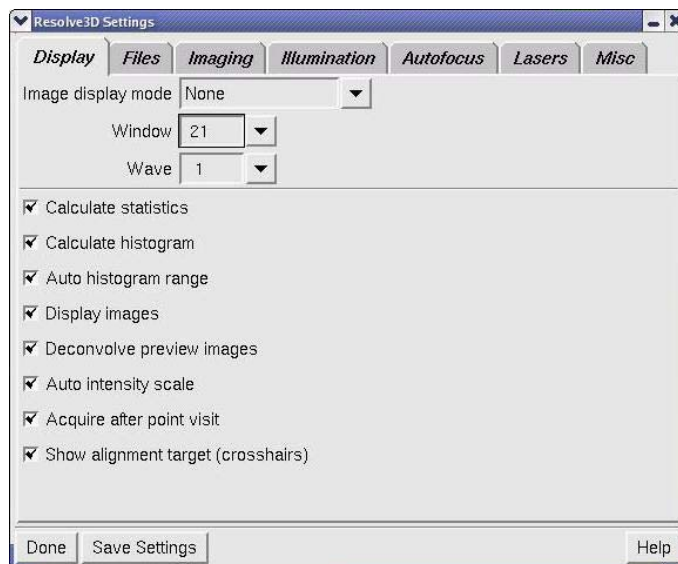

- In the Image Display mode list, select **Point Track**.
- Click the **Save Settings** button, then click **Done** to close the Resolve3D Settings window.

## Setting up Time-lapse Experiments

Time-lapse images are very useful for analyzing live specimens.

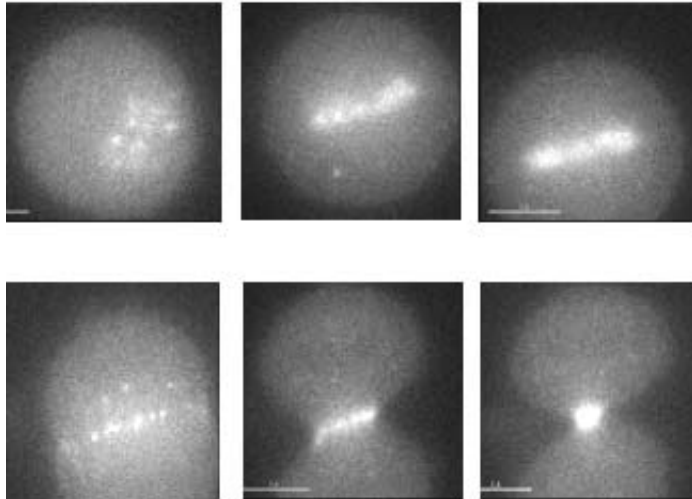

Time-lapse images showing cell mitosis

To design a time-lapse experiment:

- Select the **Time-lapse** tab under the **Design** tab on the Design/Run Experiment window.

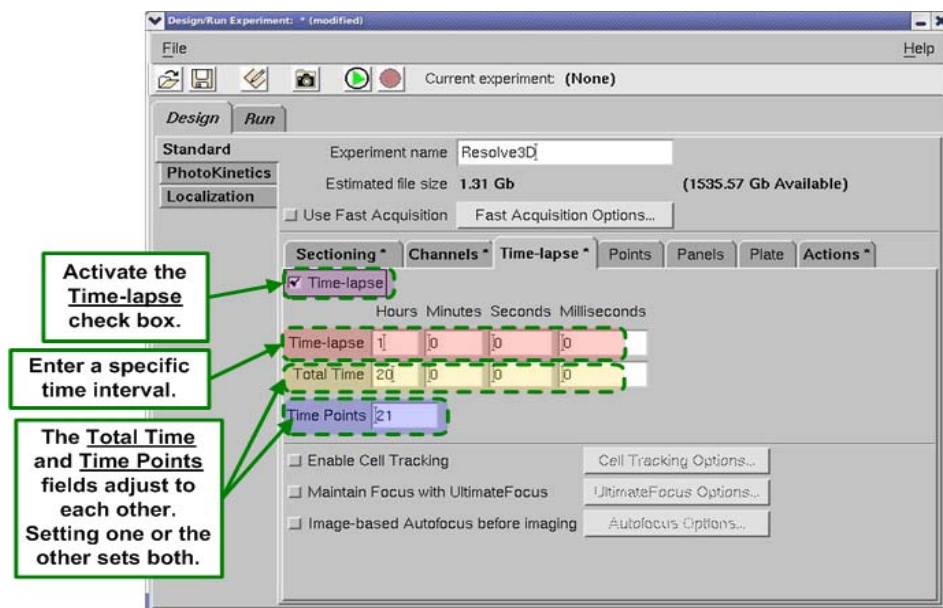

- Activate the **Time-lapse** check box.

3. If your *DeltaVision* system is using a xenon arc lamp for its broadband illumination source and you want the lamp to turn off when the experiment is completed, activate the **Lamps Off when finished** check box. (The **Lamps Off when Finished** check box is displayed only if your *DeltaVision* system is equipped with a xenon arc lamp as its broadband light source.)



**Note** When using the xenon lamp, use discretion when activating the **Lamps Off when finished** check box feature. Cycling the *DeltaVision* lamp on or off more than is necessary can reduce the xenon bulb life.

---

4. Enter the desired time interval in the **Time-lapse** field.



**Note** The minimum time interval is limited by acquisition time. If you specify a time that is less than the acquisition time, the experiment proceeds at the quickest possible rate.

---

5. Set up the remaining parameters for your experiment in one of the following ways:
  - Enter the desired number of time points in the **Time Points** field. The **Total Time** field displays the total time that will elapse during the experiment.
  - Enter the total time in the **Total Time** field. The **Time Points** field displays the number of time points for the experiment.

## Using the Actions Tab with Time-lapse Experiments

When designing time-lapse experiments, you can also use the Actions tab in the Design/Run Experiment window to further customize your experiments. The Actions tab allows you to set up additional tasks for your experiment macro to complete before, during, or after a time-lapse interval.

### To use the Actions tab:

1. At the top of the Resolve3D window, click the **Experiment** icon to open the Design/Run Experiment window.
2. Click the **Design** tab and then click the **Actions** tab.



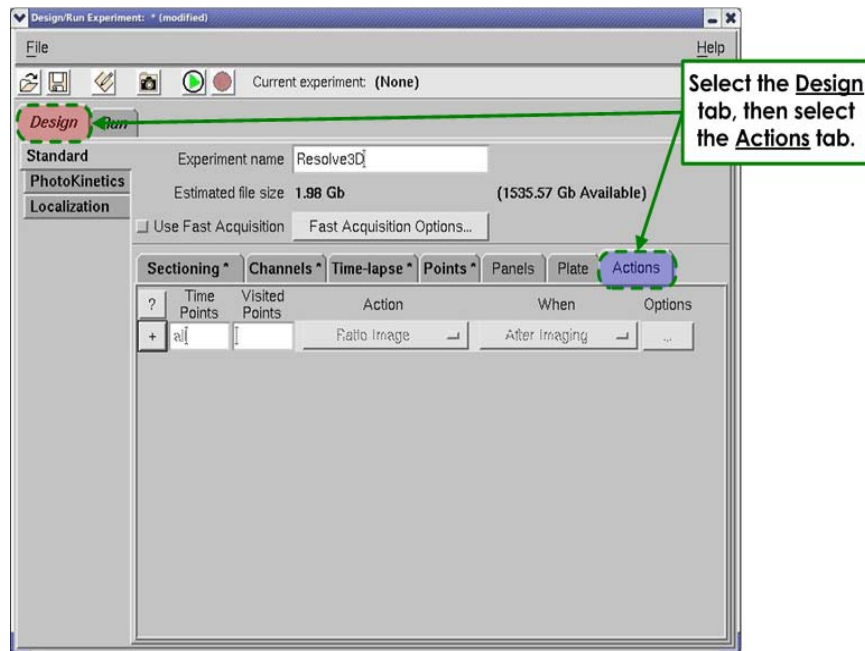

3. Fast Acquisition is useful for highly dynamic experiments in which data must be captured quickly. In general, Fast Acquisition prioritizes the acquisition process so that the imaging is completed as quickly as the system can handle it. Other processes that the system would normally be checking during the acquisition are placed “on hold” until the system has completed the task. The advantage of this method is that the time sequences within the experiment can remain more predictable when the system is focused solely on the acquisition.  
If you plan to use the Fast Acquisition method for this experiment, activate the **Use Fast Acquisition** check box.
4. If you activated the **Use Fast Acquisition** check box, click the **Fast Acquisition Options** button and continue with Step 5. Otherwise, skip to Step 8 of this procedure.
5. The Fast Acquisition Options window is displayed, as shown.

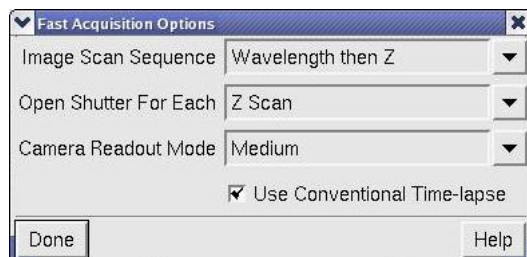

The choices for this screen are as follows:

**Image Scan Sequence** – Two options are available:

- **Wavelength then Z** causes the system to switch filter positions before changing the Z position. Use this mode when channel-to-channel alignment is critical.

- **Z then Wavelength** causes the system to collect an entire Z stack before switching filters and rescanning the specimen. This method is faster because the filter wheels are moved only once for each wavelength during the Z scan. The trade-off is that different wavelengths may not be as finely aligned as with the **Wavelength then Z** method.

**Open Shutter for Each** – Selects when the shutter should open and close during the acquisition. Three options are available:

- **Exposure** – should be used for any acquisitions that require more than one wavelength and for acquisitions using a full-frame CCD chip.
- **Z Scan** – should be used for single wavelength acquisitions.
- **Entire Scan** – should be used for time-lapse acquisitions with only one Z section and one wavelength. The shutter should be closed after each exposure unless the time-lapse duration is zero. The Entire Scan option should also be used for acquisitions utilizing an interline chip.

**Camera Readout Mode** – Selects the camera readout mode to best match the experiment requirements. The implementation of the readout mode depends on the camera model and manufacturer. Not all cameras have noticeable differences between the modes. Five options are available: **Normal, Very Fast/Aggressive, Fast/Aggressive, Medium, Slow/Careful**.

- **Normal** – is the default camera configuration, which is usually the same as Slow/Careful.
  - **Fast/Aggressive** and **Very Fast/Aggressive** readouts attempt to move electrons more quickly off of the CCD chip, which can cause electrons to be “spilled” into adjacent CCD wells. This is usually not a problem unless the CCD has collected enough light (electrons) to be near full-well capacity. In most cases, high-speed imaging does not allow sufficient time for collecting lots of photons, so the more aggressive modes usually do not cause problems in this regard.
6. Activate the **Use Conventional Time-lapse** check box. This mode allows the use of the tools on the Actions tab, including **UltimateFocus, Autofocus,** and **Cell Tracking**, even when **Fast Acquisition** is selected.



**Note** This may slow down acquisition.

---

7. When you are satisfied with your selections in the Fast Acquisition Options window, click the **Done** button to return to the **Actions** tab of the Design/Run Experiment window.
8. Add new items to the list of actions by clicking the “+” button in the far-left column. Remove unwanted items from the list of actions by clicking the “–” button in the far-left column.



**Note** Actions must be removed from the list in the reverse order in which they were added.

---

9. In the following two columns, **Time Points** and **Visited Points** may be indicated as follows:

- By the keyword: **all**
- As a range: **1–5**
- As a list of values: **1, 3, 5, 8**
- As an Nth expression: **every 3**, or **7 then every 4** (indicates 7, 11, 15, 19...)
- As a compound specification: **1–3, 5, 7 then every 3**



**Note** The above information is also available on your screen whenever you click the “?” button just left of the **Time Points** heading, on the left.

- Each row in the list of actions represents an individual action. In the **Time Points** column, select the time points at which you want the selected action to occur.
- If your experiment includes point visiting, select the appropriate points in the **Visited Points** column. Note that this column defaults to **all** if left blank.
- In the **Action** column, use the drop-down list to select the type of action to include in this experiment. Note that the details and conditions relating to each action are provided in the **Options** column at the far-right.

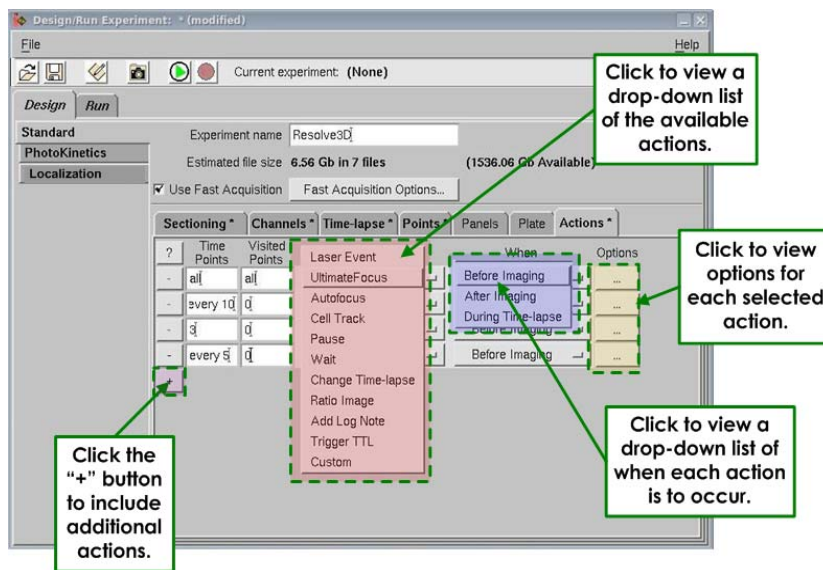

The actions available in the **Action** column are as follows:

- **Laser Event** – places a laser event into the experiment macro at each time point indicated.
- **UltimateFocus** – uses the hardware-based UltimateFocus tool at each time point indicated.
- **Autofocus** – uses the software-based Autofocus tool at each time point indicated.
- **Cell Track** – applies cell tracking for each time point indicated.
- **Pause** – stops the acquisition process at each indicated time point until the user intervenes to continue the experiment.
- **Wait** – stops the acquisition process at each indicated time point, and then waits for a specified amount of time before continuing the experiment.

- **Change Time-lapse** – changes the subsequent time-lapse interval at each time point indicated.
  - **Ratio Image** – generates a ratio image at each time point indicated. A ratio image is a simple two-channel image displayed with a ratio graph showing the mean value vs. time.
  - **Add Log Note** – inserts a note in the Resolve3D acquisition file.
  - **Trigger TTL** – inserts a TTL command into the experiment macro at each time point indicated.
  - **Custom** – allows you to insert macro command directly into the experiment macro. This action should be used by advanced users only.
13. In the **When** column, use the drop-down list to select the time frame during which you want the action to occur. The choices for this column are **Before Imaging**, **After Imaging**, or **During Time-lapse**.
14. In the **Options** column, click the button to view an Options window specific to the action you have chosen. The following subsections describe each of the possible Action Options windows.

## Laser Event

When you select **Laser Event** as the action and then select **Options**, the Laser Action Options window is displayed as shown.

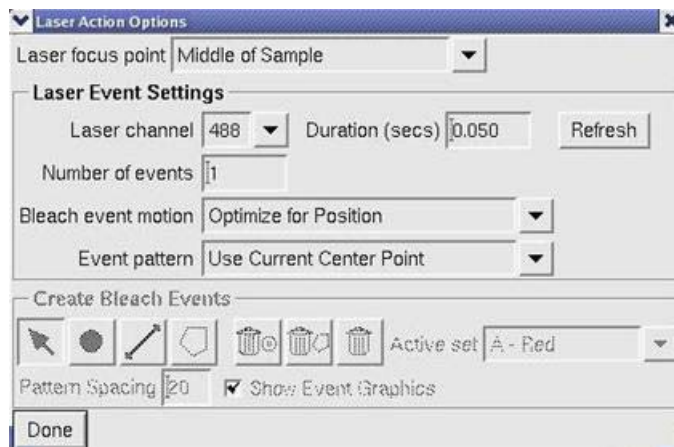

On the Laser Action Options window:

- Use the drop-down list in the **Laser focus point** field to select **Middle of Sample**, **Bottom of Sample**, or **Top of Sample**.
- Select the **Laser channel** to use and specify the **Duration** (in seconds), or use the **Refresh** button to update the active laser and duration to that currently used in the Laser Module Settings window.
- Select how many laser events you want for this action in the **Number of events** field.
- Use the drop-down list in the **Bleach event motion** field to select either **Optimize for Position** or **Optimize for Speed**.

- Use the drop-down list in the **Event pattern** field to select either **Use Current Center Point** or **Use Bleach Event Specification**.
- If you selected **Use Bleach Event Specification** in the previous step, use the now active tools in the Create Bleach Events section of the window to generate specific bleach events, otherwise, skip to the next step.
- Click the **Done** button.

## UltimateFocus

When you select **UltimateFocus** as the action and then select **Options**, the UltimateFocus Action Options window is displayed as shown.

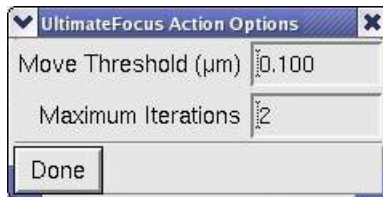

On the UltimateFocus Action Options window:

- In the **Move Threshold** field, enter the desired maximum measured focus error (in  $\mu\text{m}$ ) before a corrective action should be taken.
- In the **Maximum Iterations** field, enter the maximum measure/move sequences for this action to reach the calibrated focus point.



**Note** More iterations will take longer, but may provide better focus.

---

- Click the **Done** button.

## Autofocus

When you select **AutoFocus** as the action and then select **Options**, the Autofocus Action Options window is displayed as shown.

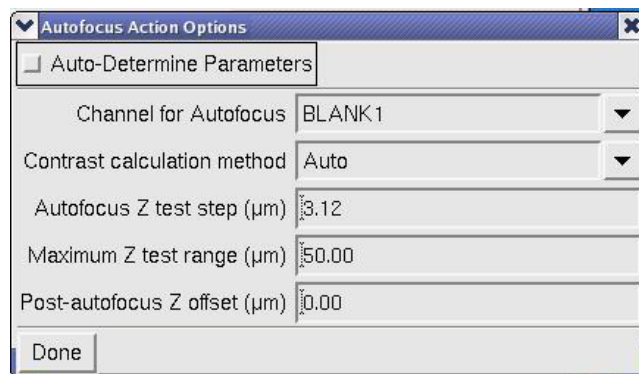

On the Autofocus Action Options window:

- To have the options in this window set automatically, activate the **Auto-Determine Parameters** check box. Then click the **Done** button.  
If you do not activate the **Auto-Determine Parameters** check box, set the remaining fields in the window as follows:
- Use the drop-down list in the **Channel for Autofocus** field to select the channel you want to use for Autofocus.
- Use the drop-down list in the **Contrast calculation method** field to select **Auto, Fluorescence (Light on Dark)**, or **Brightfield (Dark on Light)**.
- Select the **Autofocus Z test step** (in  $\mu\text{m}$ ) for this experiment.
- Choose the **Maximum Z test range** (in  $\mu\text{m}$ ) for this experiment.
- Indicate any **Post-autofocus Z offset** (in  $\mu\text{m}$ ) for this experiment.
- Click the **Done** button.



**Note** For additional information on these settings, see "Settings Window Autofocus Options" on Page E.37 in *Appendix E*.

## Cell Track

When you select **Cell Track** as the action and then select **Options**, the Cell Tracking Action Options window is displayed as shown.

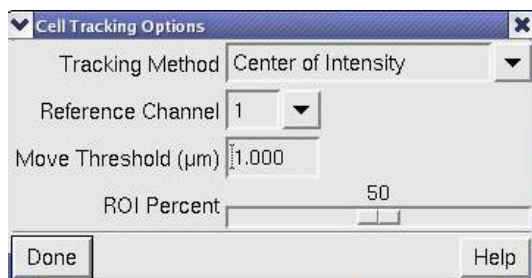

On the Cell Tracking Options window:

- Use the drop-down list in the **Tracking Method** field to select either **Center of Intensity** or **Center of Shape**.
- Use the drop-down list in the **Reference Channel** field to choose the channel to use for reference.
- Enter the desired **Move Threshold** (in  $\mu\text{m}$ ).
- Use the **ROI Percent** slider to indicate the appropriate ROI percentage.
- Click the **Done** button.

## Pause

The **Pause** action does not have a Pause Action Option window. Use this action to pause the experiment either before or after imaging. The **Pause** action requires user intervention before the experiment can continue.

## Wait

When you select **Wait** as the action and then select **Options**, the Wait Action Options window is displayed as shown.

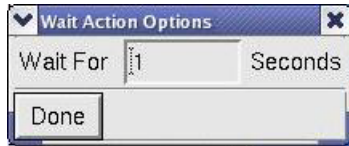

On the Wait Action Options window:

- Enter the amount of time (in seconds) for the experiment to wait. The **Wait** action does not require user intervention for the experiment to continue.
- Click the **Done** button.

## Change Time-lapse

When you select **Change Time-lapse** as the action and then select **Options**, the Time-lapse Action Options window is displayed as shown.



On the Time-lapse Action Options window:

- Enter the new time-lapse (in seconds) for the remainder of this experiment.
- Click the **Done** button.

## Ratio Image

When you select **Ratio Image** as the action and then select **Options**, the Ratio Image Action Options window is displayed as shown.

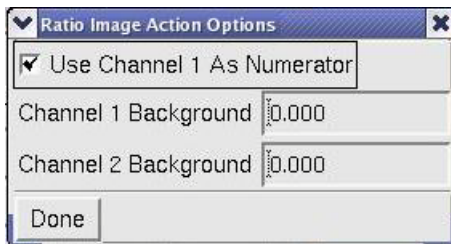

A ratio image is basically a method of viewing experiment status. On the Ratio Image Action Options window:

- To use Channel 1 as the ratio's numerator, activate the **Use Channel 1 as Numerator** check box.

- In the **Channel 1** and **Channel 2 Background** fields, enter the intensity values to subtract from each channel.
- Click the **Done** button.

While a ratio imaging experiment is running, a two-channel time-lapse image is displayed along with a ratio graph showing the mean value vs. time. The mean value for a ratio graph is calculated using a specified portion of the image. See *Using Ratio Imaging* on Page 7.13 for details.

## Add Log Note

When you select **Add Log Note** as the action and then select **Options**, the Log Note Action Options window is displayed as shown.

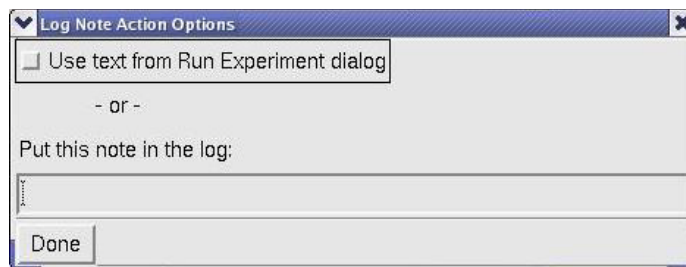

On the Log Note Action Options window:

- Activate the **Use text from Run Experiment dialog** check box to use the text from the **Add note to log** field on the Run Experiment tab.
- If you leave the check box inactive, enter the text for your log note in the field provided.
- Click the **Done** button.

## Trigger TTL

You can insert TTL triggers into an experiment macro to initiate specific events from various components during your experiment. When you select **Trigger TTL** as the action and then select **Options**, the TTL Action Options window is displayed as shown.



On the TTL Action Options window:

- Enter the appropriate channel in the **TTL Channel** field.
- Enter the desired pulse duration for this TTL trigger in the **Pulse Duration** field.
- Click the **Done** button.



## Custom



**CAUTION!** The use of **Custom Actions** should be considered by advanced users only. In particular, adding any command to the macro that changes the number of image frames may cause Resolve3D to fail or behave unexpectedly.

When you select **Custom** as the action and then select **Options**, the Custom Action Options window is displayed as shown.

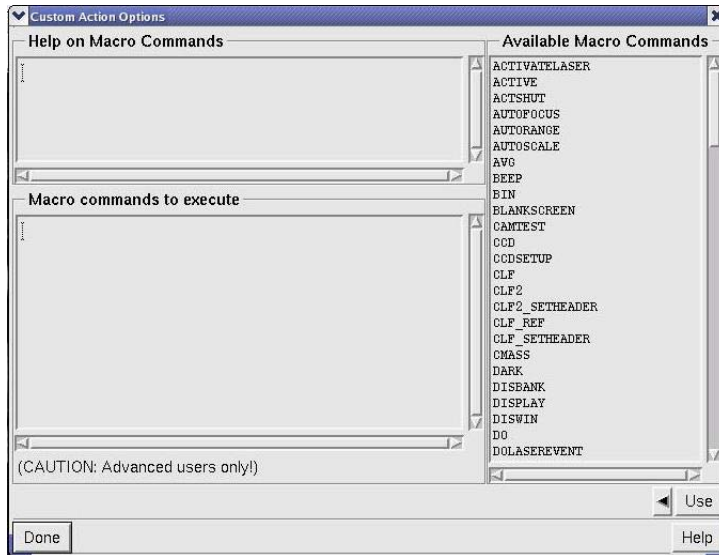

- Use the Custom Action Options window to specify macro commands that will be executed at the specified time points.



**CAUTION!** Specifying any macro that changes the size (number of X, Y, Z, Time, or Channels) can result in image files that cannot be used by softWoRx.

- When you are satisfied with the Custom Actions Options window, click the **Done** button.

## Sending TTL Triggers to External Devices

For sending TTL signals to devices external to the DeltaVision system, you'll need a cable to run from the back of the IC/MIC to the external device. You can order this cable directly from GE, or you can ask your GE representative for a pin-out diagram of the cable so you can build your own.



**Note** All outputs from a DeltaVision system's TTL interface are Active High by default.

## Collecting Panel Images over Large Areas

Panel collection macros are useful when you want to scan a large area with a relatively high magnification lens. You can use the panels as a means of reviewing a large area of a slide, or as data that you want to stitch together to form a single, large image.

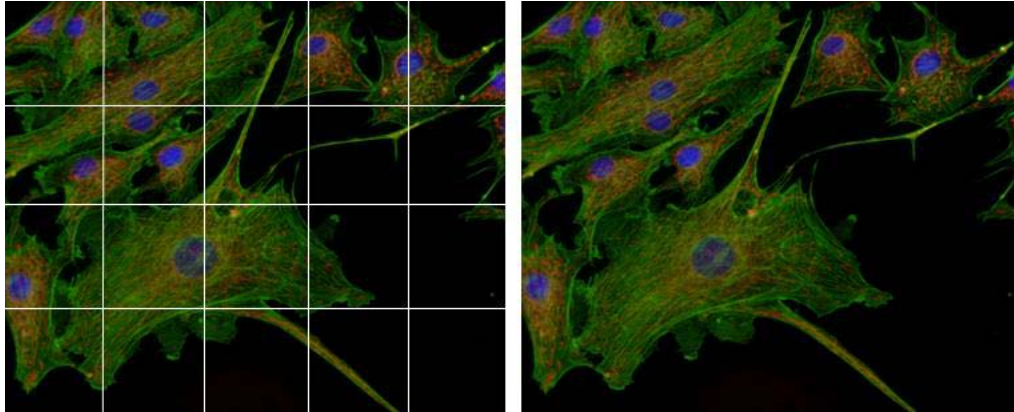

A set of panel images (left) can be stitched together to create a single image (right).

Image files that are collected with Panel Collection enabled may be stitched to create a single .dv file. For details, see “Stitching” in the [softWoRx Imaging Workstation User's Manual](#).



**CAUTION!** Do not try to reuse panel collection experiment macros. These macros are sensitive to microscope settings such as image size and magnification because the number of panels required depends upon many factors.

## Determining Border Rolloff Voxels

Before you collect panel images, you must first determine the number of voxels in the Border Rolloff that is used in Deconvolution.



**Note** Conceptually, a *voxel* is a three-dimensional pixel. So, while a pixel generally refers to XY data, a voxel includes information from the Z (or depth) plane.

### To determine Border Rolloff Voxels:

1. Determine the size of the panels that you plan to collect.



**Tip** Smaller panels work best because they have the flattest intensity distribution.

2. From the *softWoRx* main menu, choose **Process | Deconvolve** to open the Deconvolve window. In the **Input** field, enter the file name of an image that is similar to the panel size. (You can acquire and save a blank image of that size for this purpose.)

3. Click the **More Options** button to open the More Deconvolution Options window and record the value that is displayed in the **Border Rolloff (voxels)** field.

## Collecting Panel Images

### To collect 3D panel images:

1. From the Resolve3D window, choose **View | Point List**. In the Point List window, choose **Mark Point** and mark points in two opposite corners to define the area of your final composite image.
2. In the Resolve3D window, click **Experiment** to open the Design/Run Experiment window.
3. Click the **Design Experiment** tab. Then set up the Sectioning and Channels information in the same way that you would for standard data collection.
4. In the Point List window, select one of the points that you marked in Step 1 and click **Visit Point**.
5. Click the Panels tab under the Design Experiment tab. Then select the **Collect Panels** option.
6. Click **Get Start** under the Panels tab. Then visit the other point that you marked in Step 1 and click **Get End**. (Alternatively, you can enter the coordinates that are displayed in the Point List window.)
7. In the **Overlap (pixels)** field, enter at least twice the number of border rolloff voxels as you recorded when you determined border rolloff voxels (see Page 4.30).
8. Save and run the experiment.

For instructions on how to use *softWoRx* to stitch panels together, see the *softWoRx Imaging Workstation User's Manual*.



**Note** You cannot easily use Panel Collection with time-lapse or point-visiting experiments. It is possible only by editing the header.

---



## 5. Acquiring Data from Live Specimens

---

This chapter shows how to use the following features for imaging live cells with *DeltaVision*.

- Set up *Experiment Macros* to automatically focus before acquiring each image. This is useful for cells that move during the experiment.
- Use *Cell Tracking* to follow cells as they move laterally and move the stage to keep them in the field of view.
- Use *Optical Axis Integration* (or OAI; also referred to as *Z Sweep Acquisition*) to acquire a 2D projection. This method collects and integrates one continuous image through an extended Z movement. Z Sweep Acquisition is much faster than the traditional technique of collecting an individual image at each focal plane. It also reduces the risk of specimen damage and has less total camera read noise.
- *Acquire Reference Images* that can be used for Differential Interference Contrast (DIC) and other types of analysis.

### Using Autofocus in Experiment Macros

You can set up your experiment macro to automatically focus before each image is acquired. This is especially useful for long time-lapse experiments that are susceptible to changes in environmental conditions. Autofocus allows you to acquire focused images without closely monitoring the experiment. The contrast-based autofocus algorithm is a software method that uses both image contrast and peak image intensity to determine when the specimen is in focus.

To optimize the focus position for *DeltaVision*, you must find the Z position where the contrast is greatest. However, this position may not always be at the optimal in-focus plane of the sample. Autofocus allows you to adjust several parameters within the standard algorithm so that the final Z position is most favorable for the specific sample. Limiting the step size and maximum Z range of travel can limit the effects of objects that are not of interest. In cases where the contrast outside of the actual middle of the sample is highest, you can create an offset so that the middle of the sample is located during the Autofocus process.

The Autofocus option works the same way as the **AF** button on the Resolve3D window. Use the following instructions to include this option in the experiment macro.

**To set up an experiment that automatically focuses before acquiring points:**

1. At the top of the Resolve3D window, click the **Experiment** icon to open the Design/Run Experiment window.
2. Click the **Design** tab, click the **Standard** tab, and then click the **Time-lapse** tab.

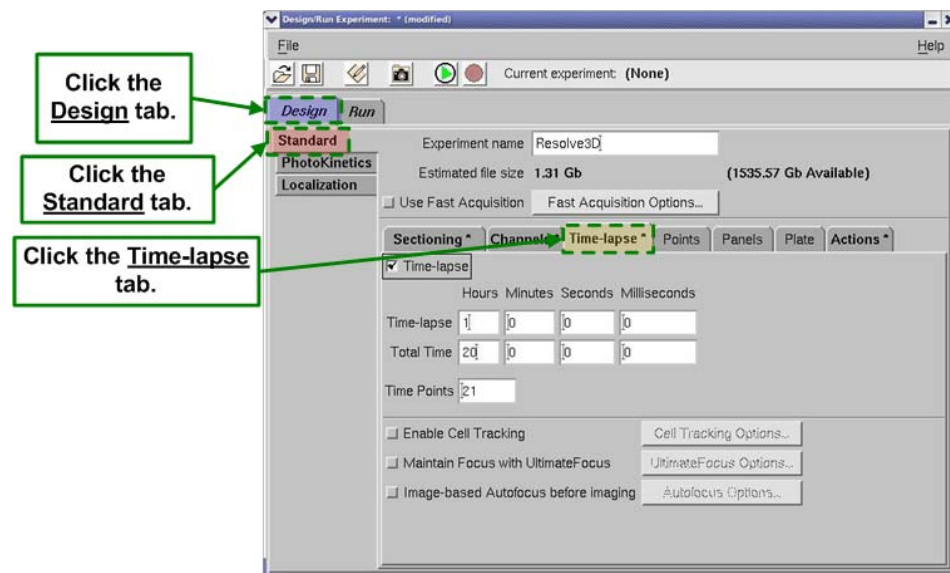

3. Activate the **Image-based Autofocus before imaging** check box. When this option is selected, the software automatically determines the parameters for the Autofocus process.
4. To change the various Autofocus parameters, click the **Autofocus Options** button. The Resolve3D Settings window is displayed with the **Autofocus** tab selected.

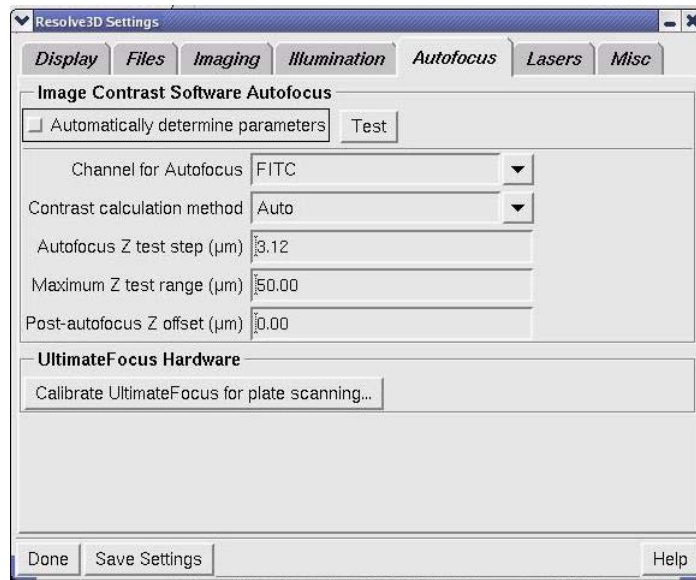

5. Deselect the **Automatically determine parameters** option near the top of the window. The remaining parameters in the window become active.

The Autofocus parameters in this window are described in “Settings Window Autofocus Options” on Page E.37.

## Tracking Cells

Cell Tracking moves the stage laterally to follow cells as they move during a time-lapse experiment. With the Enable Cell Tracking option selected, DeltaVision automatically keeps cells in the field of view as they move during a time-lapse experiment.

After you specify a region of interest (or ROI) around a specific portion of the sample, the software determines the center of the cell and establishes a recognizable pattern within the ROI. In subsequent images, the software recognizes this pattern and recalculates the center of the cell on-the-fly. The position of the new center is compared with the position of the previous center and, if the cell has moved beyond a specified threshold, the system automatically moves the stage and re-centers the cell in the field of view.

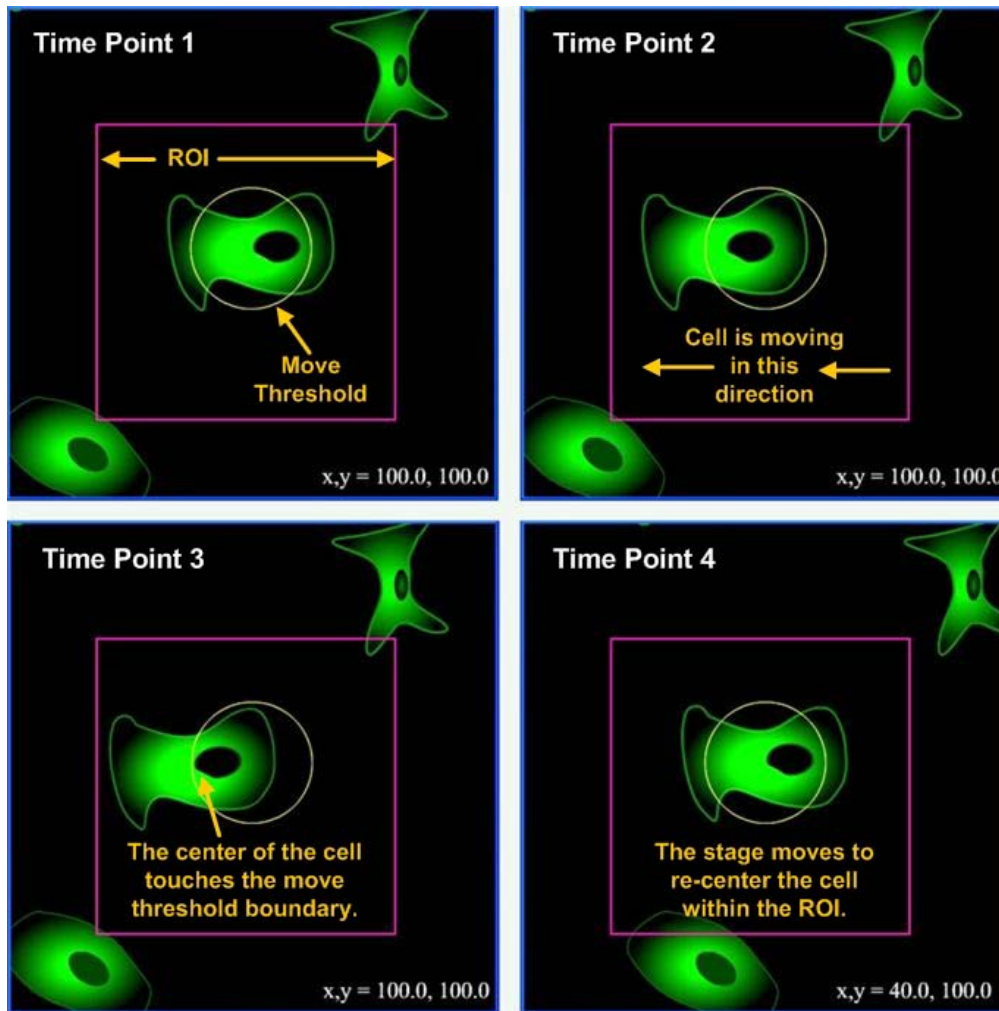

At Time Points 1 and 2, the cell is moving through the ROI (the inner square), but the center is still within the Move Threshold (the circle). At Time Point 3, once the center of the cell touches the threshold boundary, the stage moves to re-center the cell within the ROI. (Note the new stage position displayed in the lower-right corner of Time Point 4.)

#### To use Cell Tracking:

1. Set up a time-lapse experiment as shown in "Setting up Time-lapse Experiments" on Page 4.19.
2. On the **Time-lapse** tab in the Design/Run Experiment window, activate the **Enable Cell Tracking** check box.



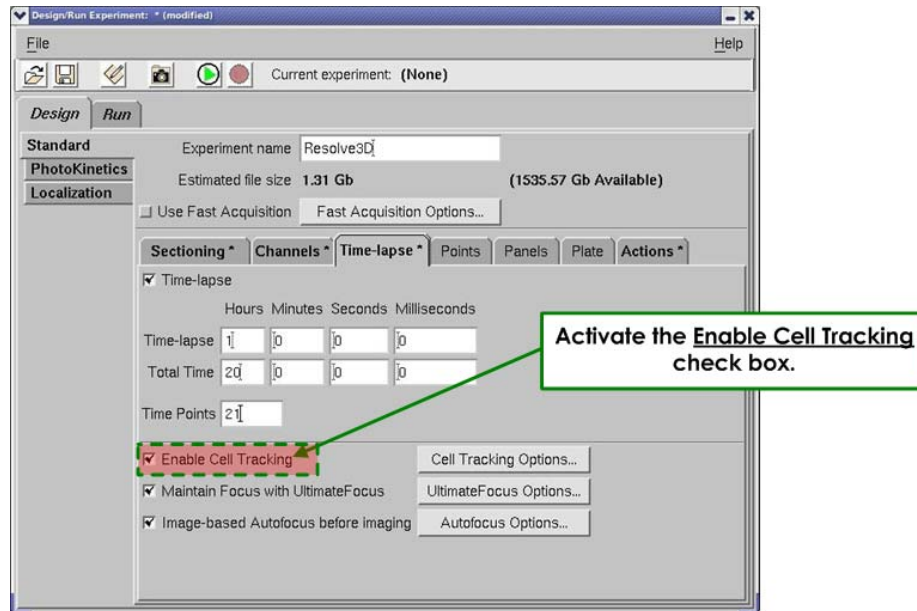

3. Click the **Cell Tracking Options** button. The Cell Tracking Options window is displayed.

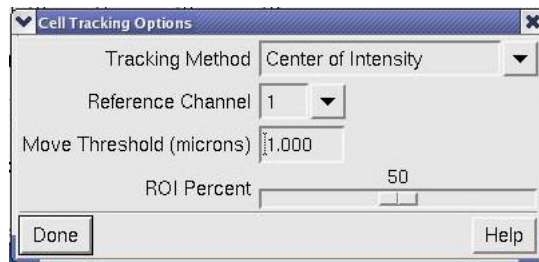

**Cell Tracking Options Window**

4. Manually acquire an image for each channel and determine which single channel best identifies the features of your specimen. In the **Reference Channel** list, specify that channel. (The channels are numbered in the order in which they are listed on the Design Experiment Channels tab.)



**Note** DeltaVision uses the reference channel for image recognition.

5. In the **Move Threshold** field, enter the distance in microns that the cell must move to trigger stage movement.
6. Specify the area around the cell (the region of interest or ROI) that you want *DeltaVision* to use for image recognition. For more about this option, see ROI Percent on Page 5.8.
7. If you are performing an experiment on a single cell, use the stage controls to center the cell (laterally) in the field of view. If you are performing a point visiting experiment, make sure that the points that you are monitoring are centered before you start your experiment.
8. Click the **Run** tab and then click the **Green Arrow**  button to start the scan.

## Guidelines for specifying Cell Tracking Options

You can specify several parameters that *DeltaVision* uses to track cells:

- Tracking Method
- Reference Channel
- Move Threshold
- ROI Percent

### Tracking Method

The tracking method is the process *DeltaVision* uses to determine the center of the feature. This center is recalculated after each image is acquired. You can choose between two tracking methods:

- **Center of Intensity** calculates the center of the feature based on intensity values.
- **Center of Geometry** calculates the center of the feature based on its geometry.

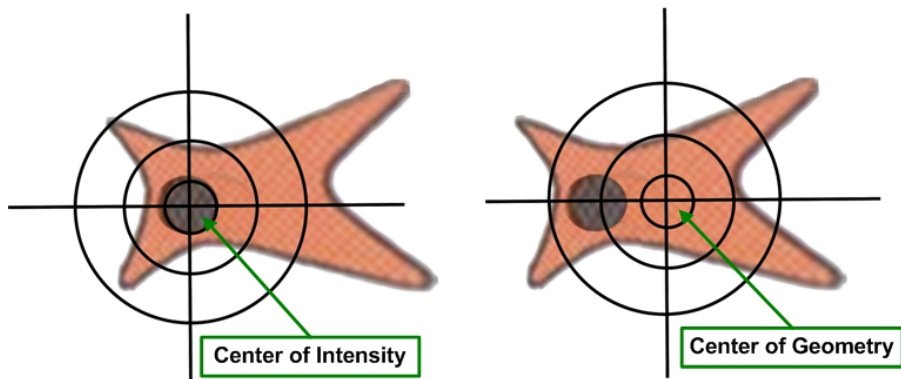

### Reference Channel

*DeltaVision* uses the reference channel for pattern recognition. If you are acquiring more than one channel, choose the channel that has the most contiguous features.



**Note** The term, *Reference Channel* should not be confused with *Reference Image*, which is something very different. Reference images are described later in this chapter in *Acquiring a Reference Image*.

---

Channels are numbered as they appear in the Experiment Designer window. In the following example, DAPI is Channel 1, FITC is Channel 2, and CY-5 is Channel 3.

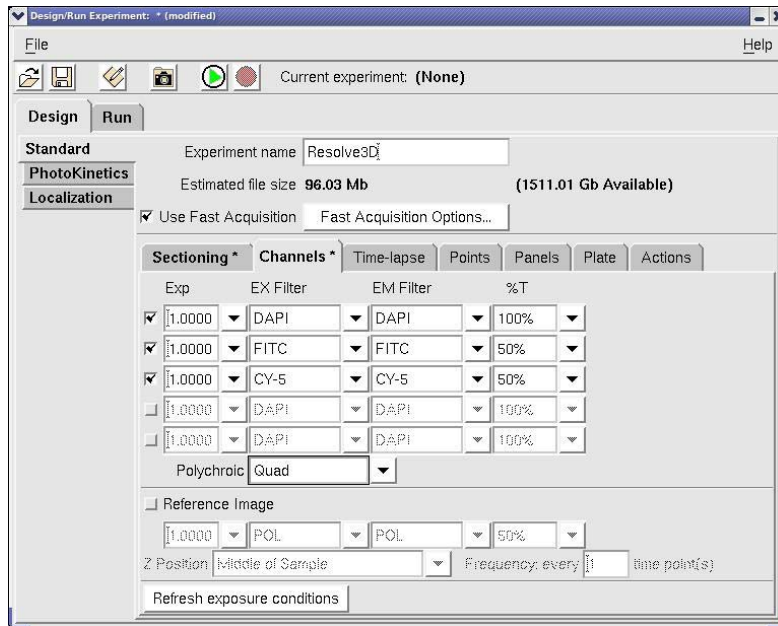

## Move Threshold

The move threshold is the distance the center of the cell (as defined by the tracking method) must travel before the system resets the stage. When the cell moves beyond this threshold, the stage moves so that the center of the cell retains its original position in relationship to the center of the field of view.

Live cells, by their very nature, are constantly on the move. When choosing a move threshold, it is important to select one that is small enough to keep the cell in the field of view, yet large enough to buffer out needless stage movement that could result from numerous small cell movements.

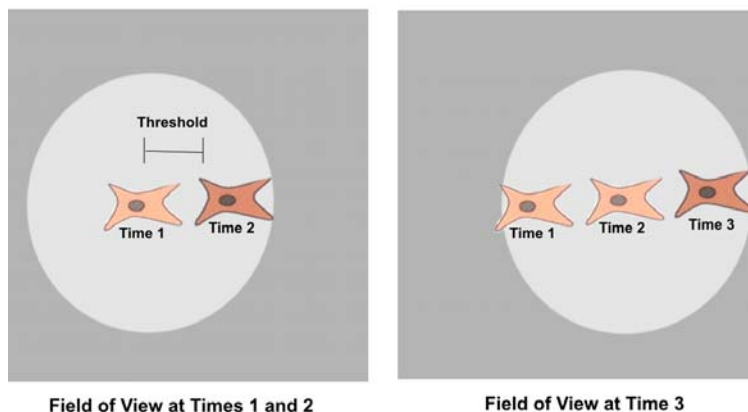

Cell tracking lags cell movement. Cell movement exceeds the threshold between Time Points 1 and 2 (left). In response, *DeltaVision* moves the stage so that it is centered on the cell position at Time Point 2. The stage is at this position when Time Point 3 is acquired (right).

## ROI Percent

With rare exceptions, few live cells are isolated on the substrate. Most are genetically “programmed” to seek attachment and communication with other cells. When performing live cell microscopy, not only is it important to filter out unnecessary stage movement, it is also important to define an appropriate region of interest within the field of view. This region of interest must be large enough to include the entire cell or structure of interest, yet small enough to exclude other cells or structures that may tend to wander in and out of the field of view throughout the experiment.

The ROI Percent parameter defines how much of the field of view the software will use for image recognition. In the software, ROI units are specified as a percentage of the width of the field of view. For example, a 50% ROI has a width that is 50% of the width of the field of view.

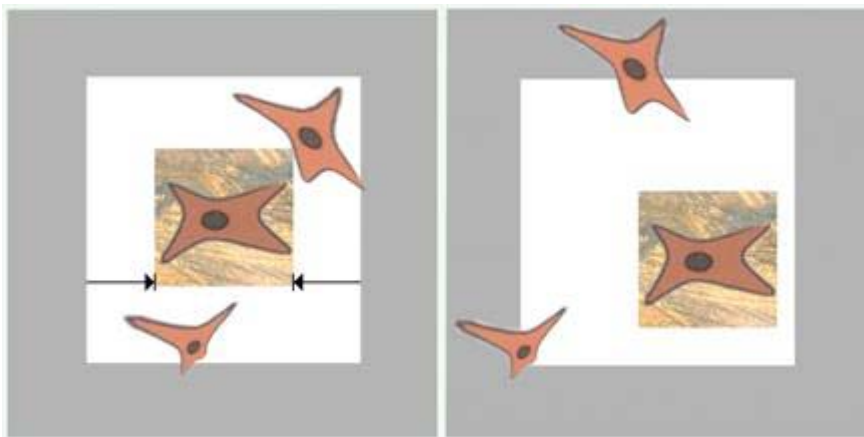

In the first image, the width of the ROI is defined as 50% of the width of the field of view. In the second image, the stage has moved to keep the cell of interest within the ROI. Perimeter cells have also moved, almost entirely out of the field.



**Tip** During a time-lapse experiment, it's possible to lose the cell as it moves out of the field-of-view. When this occurs, you can update the point coordinates by manually finding the cell and centering it in the field-of-view. The point list is automatically updated.

## Acquiring 2D Z Projections with OAI

Optical Axis Integration (or OAI), also referred to as Z Sweep Acquisition, is useful for acquiring 2D Z projections of live specimens. Instead of collecting an individual image at each focal plane, OAI collects and integrates one continuous image through an extended Z movement.

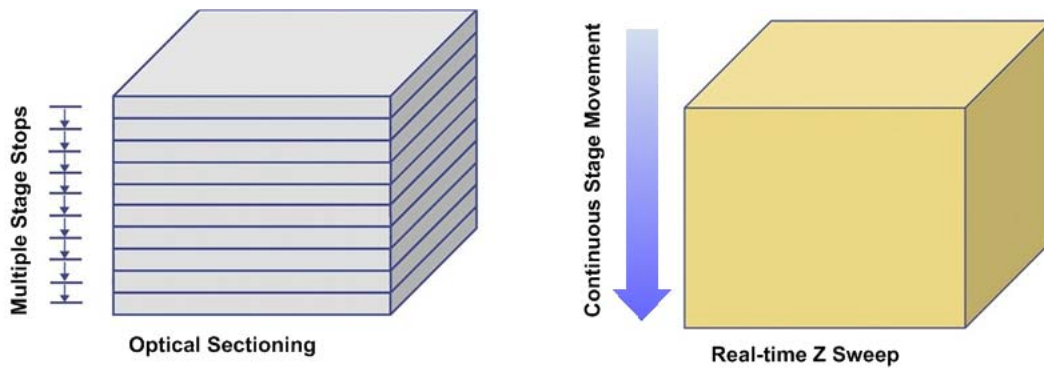

Instead of acquiring multiple images, Real-Time Z Sweep acquires one image during a continuous stage movement and instantly creates a 2D Z Projection.

Z Sweep Acquisition has significant advantages for applications such as Leading Edge Motion Analysis, Fast Organelle Dynamics, Microtubule Dynamics, and Fluorescence in situ Hybridization (FISH). It is especially useful for studies of objects that are moving in 3D space (e.g., kinetichores in a cell nucleus or other rapidly moving structures).

## Z Sweep Acquisition versus Traditional Projections

If you are acquiring data objects that you plan to use for 2D projections, Z Sweep Acquisition provides several advantages over creating 2D projections from multiple optical sections:

- Complete Z data acquisition collects all data in the interval of interest (with 2D imaging or Z section sampling, some data is lost.)
- Fast data acquisition provides accurate image registration of rapidly moving objects.
- Low total exposure time reduces the risk of damage to the specimen.
- Low total read noise (the camera is only read once) improves signal-to-noise ratio.



**Note** For samples that contain a large amount of fluorescence throughout 3D space (for example, a tumor spheroid that has a lot of fluorescence), optical sectioning may provide better results than OAI.

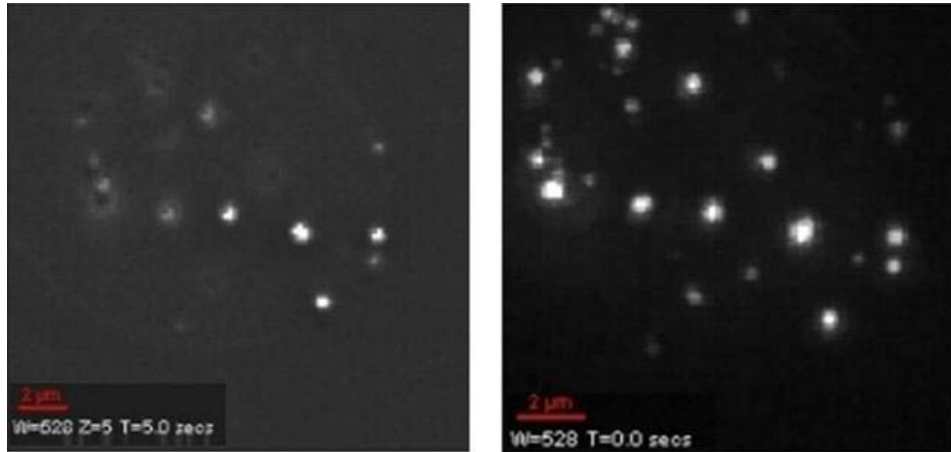

The following 2D image of endosomes in a HeLa cell (left) and a 2D Z projection (right) of the same area were acquired under similar conditions. The additional data in the 2D Z projection include objects that moved out of the depth-of-field of the 2D image during the data acquisition process.



endosomes in a HeLa cell (left) and an instant 2D Z projection (right) of the same area

## Using Z Sweep Acquisition

### To set up a Z Sweep Acquisition Experiment:

1. Set up your experiment as shown in “Creating and Running an Experiment Macro” on Page 4.1.
2. In the Resolve3D window, use the Z Slider on the right side of the Resolve3D window to find the best focal plane. Drag the slider up to find the top of your sample. (When you release the mouse button, an image is acquired and displayed in the Data Collection window.) Drag the slider and acquire images until you are satisfied. Then press the  button to mark that location. Next, use the slider to find the bottom of the sample. When you are satisfied, press the  button to mark that location.

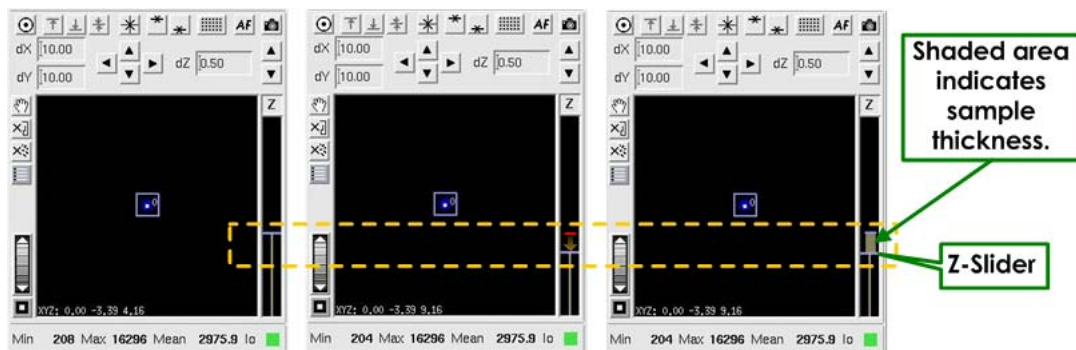

Use the Z slider to find the top and bottom of a sample. The sample thickness is indicated by the wide line on the Z slider (shown on the right image).

3. Click **Experiment** to open the Design/Run Experiment window. Then click the **Sectioning** tab.
4. Select the **Z Sectioning** and **Enable OAI Scan** options.

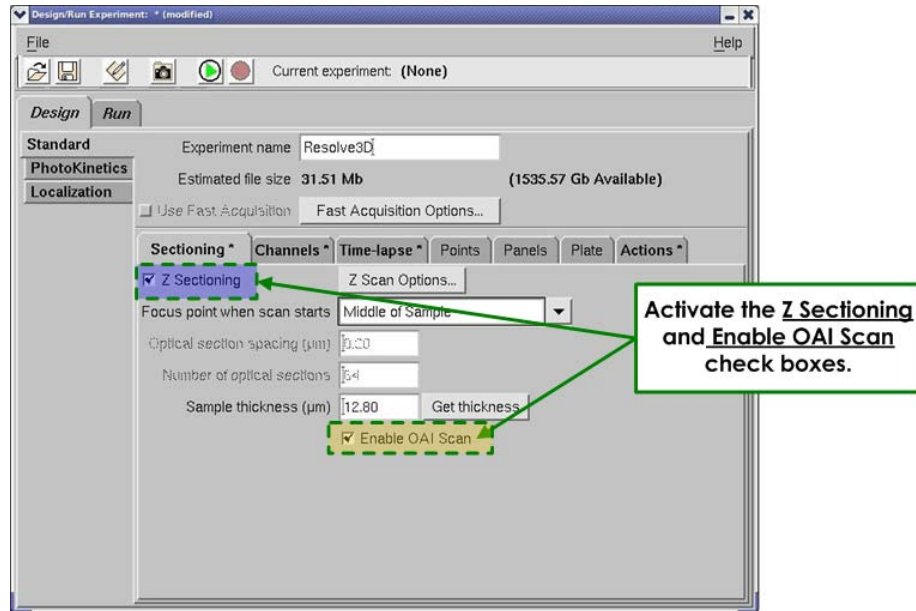

5. Click the **Run** tab and click the **Green Arrow**  button in the tool bar at the top of the screen to start the experiment.



**Note** When deconvolving OAI images, select the **More Options** button on the Deconvolve window, and then select the **Deconvolve Projections** option in the **More Options** window.

## Acquiring a Reference Image

You can use either an alternate filter with the excitation light source or the transmitted light to acquire a reference image that can be combined with other images. This option is useful for Differential Interference Contrast (DIC) analysis. It can also be useful for other types of reference images.

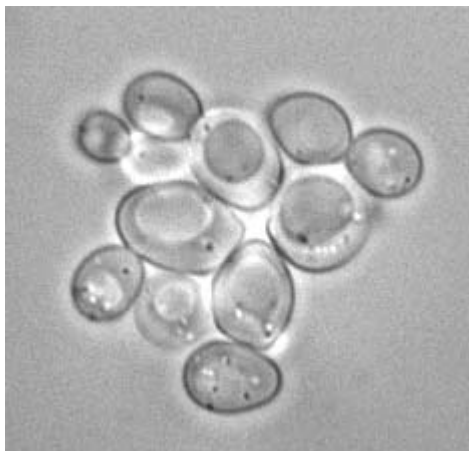

A reference image of yeast cells

A reference image is a single image taken from a Z stack. You can specify to acquire the reference image at the top, middle, or bottom of the sample.

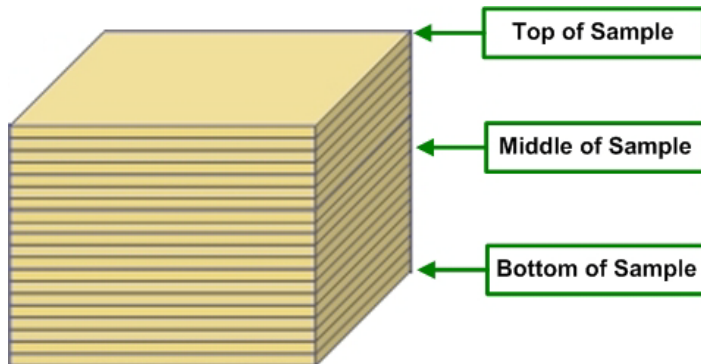

**Note** It is important to optimize the reference image settings prior to defining them in the Experiment Designer.

---

#### To create a reference image:

1. Set up a 3D Sectioning experiment (see "Sectioning Specimens for 3D Images" on Page 4.3).
2. In the Design/Run Experiment window, click the **Channels** tab and select the channels for your experiment (see "Selecting Filters" on Page 4.8).
3. Activate the **Reference Image** check box on the bottom-left side of the window.
4. In the Z position list, choose whether to acquire the reference image at the top, middle, or bottom of the sample.
5. Under the **Reference Image** check box, select which filters to use.
6. In the last field (bottom-right), select the light source to use for the image. **EX** is for a broadband light source (the xenon lamp or InsightSSI), **TRANS** is for transmitted light, and **LASER** is for a laser light source.



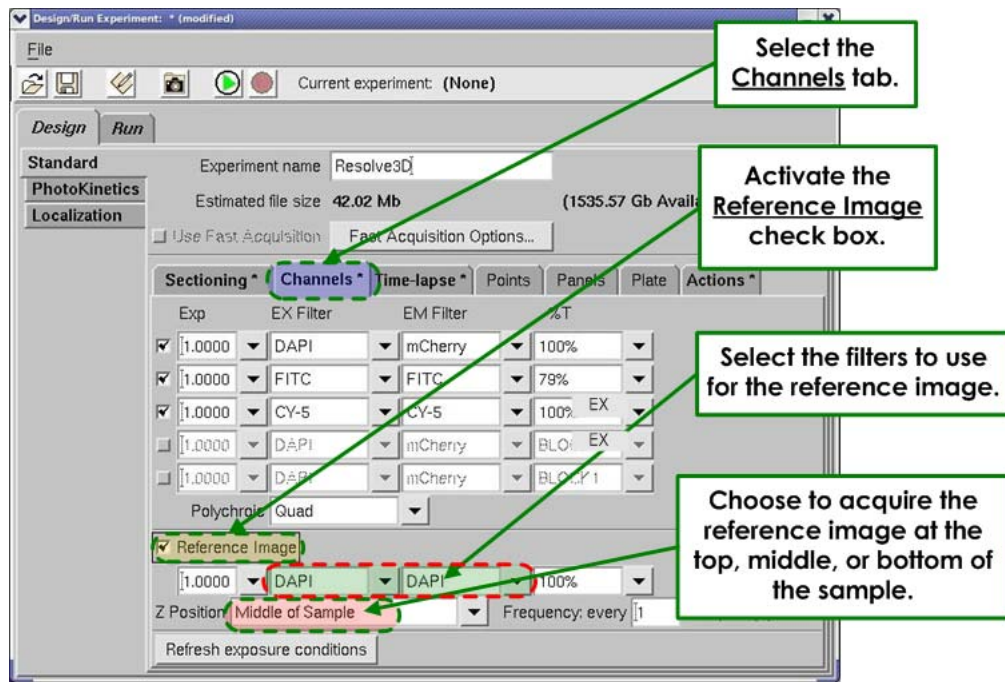

This experiment specifies using the DAPI and Cy-5 filters to acquire images of each section and using the transmitted light to acquire a reference image using the DAPI filter in the middle of the sample.

7. Save and Run the Experiment.

After *DeltaVision* acquires the data, it creates two image files. One file contains the reference image data (with the extension `_R3D_REF.dv`) and the other file contains all of the other data.



## 6. Localization Microscopy

---

- ◆ *Localization Microscopy Overview*
- ◆ *Dense Stochastic Sampling Imaging (DSSI)*
- ◆ *Acquiring Localization Images*
- ◆ *Dense Stochastic Sampling Imaging Analysis*

### Localization Microscopy Overview

A single fluorophore behaves as a point source of light. When viewed through a microscope however, the observed image of the fluorophore is much larger than the fluorophore itself. The broadening of the image is due to diffraction, which is caused by the interaction between the emitted photons from the fluorophore and the optics of the microscope. This observed broadening of the image is termed the point-spread function (PSF) of the microscope and has traditionally limited the spatial resolution of a light microscope to 250 nm laterally (x and y) and 500 nm axially (in z).

Though the image of a fluorophore is broadened by diffraction, the center of the image is the location of the fluorophore. Therefore, when a single fluorophore is excited, the position of this fluorophore can be determined very precisely by determining the centroid of its image. If one protein was tagged with a single fluorophore inside a cell, we would be able to determine its location with high precision.

In cells, many proteins exist in dense complexes such that the distance between the proteins is smaller than the wavelength of light used to image them. When illuminated simultaneously, these densely labeled protein complexes appear as a single fluorescent region in the microscope, making it difficult to distinguish individual fluorophores or observe spatial organization on length scales below a few hundred nanometers.

Since it is difficult to spatially resolve closely spaced fluorophores, localization microscopy uses the approach of resolving individual fluorophores temporally. Instead of simultaneously exciting all the fluorophores in a sample, each fluorophore is individually excited making it possible to locate the position of each fluorophore in a sample. Once each fluorophore's position has been determined, the positions can be plotted as points in space to reconstruct a final image with nanometer resolution.

To observe each protein individually, photo-switchable fluorophores are used. These fluorophores are dyes or fluorescent proteins that can be switched on or off under the control of an external light source, also known as an "activation" source or laser. The activation laser illuminates the entire sample, but at such low levels that only a few fluorophores are stochastically activated at any given time. This allows individual detection of each fluorophore in a sample. Computer algorithms are used to locate each fluorophore and assemble these locations into a final image.

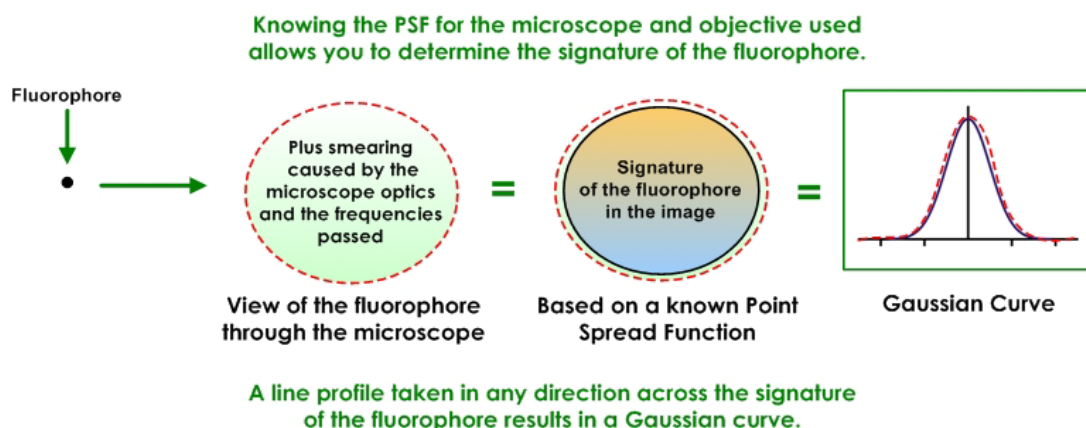

## Localization Microscopy Experiments

The goal of a localization experiment is to capture a sequence of high-contrast images of spatially distinct fluorophores. Using TIRF or near-TIRF illumination reduces out-of-focus light leading to higher signal-to-noise ratios for excited fluorophores. This allows better detection and positioning for each fluorophore.

During imaging, the density of excited fluorophores is regulated by their photophysics. Some fluorophores can be "activated" using external light sources (activation lasers), which alter the conformation of the fluorophore allowing it to be excited by a different light source (excitation laser). Through control of the activation laser, the localization experiment modulates the density of activated fluorophores which are then excited using the excitation laser. The excitation laser acts to excite and switch off active fluorophores. Over time, the excitation laser will ultimately photobleach the sample. Effectively, the excitation laser is both imaging the active set of fluorophores while driving them to an "off" state (or to another excited state, such as a triplet state). There is a balance in excitation power between photoconversion and photobleaching. Low excitation power

may lead to inadequate photoswitching because the fluorophores will not be able to be switched to an “off” state before others turn on. This can be compensated for by increasing the exposure time of the experiment and by decreasing the power of the activation laser. This will increase the acquisition time for the experiment. High excitation powers may cause the fluorophores to photobleach before they can be imaged. Ideally, the excitation power level allows each fluorophore to be photoconverted and switched off within a single exposure.

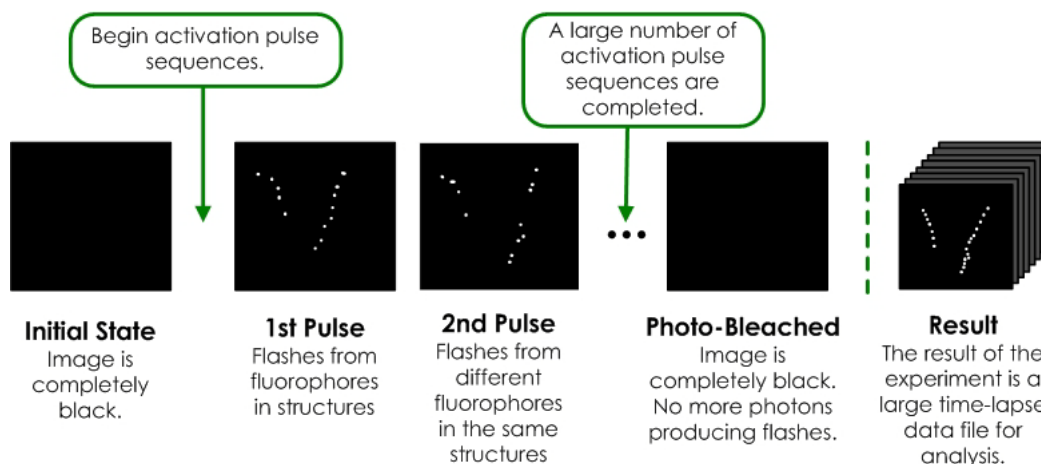

If a fluorophore responds to an activation laser source, varying the amount of activation energy at the sample will control the number of active fluorophores in a stochastic manner. The amount of activation power required varies based on fluorophore, labeling density, and buffer conditions. Generally, samples will require less activation in the beginning of an experiment than at the end of an experiment because photobleaching will decrease the fluorophore density within the sample. Many photoswitchable dyes, photoconvertible fluorescent proteins, or photoactivatable fluorescent proteins are activated by near-UV light. Some dyes may be specifically paired to another activating dye.

The localization experiment moderates the activation and excitation lasers through activation/excitation sequences. The sequence consists of a pulse of activation laser light followed by a train of reporter images in the excitation laser channel. The activation/excitation sequence is repeated until the sample is photobleached or sufficient data has been collected. The speed of acquisition depends on the density of fluorophores within a sample, with higher density labeling requiring longer acquisition times, since there are more fluorophores within a single diffraction-limited spot.

A localization experiment with only one activation laser source, will use one wavelength for each activation pulse and return a time-lapse DV file of the excitation events from the

fluorophores within the sample. Each frame of the movie will contain a few events from the fluorophores that were stochastically activated, excited, and imaged in that frame.

### Single Activation Experiment

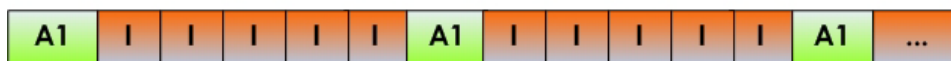

**A1** = Activation Pulse [Ex Wavelength, Power, Duration] {568 Laser}  
**I** = Imaging of Reporter [Ex and Em Wavelengths, ND, nFrames] {642 Laser / Cy5 TIRF}

Multi-color images can be obtained for as many as three activation/excitation sequences by specifying additional activation lasers and the number of subsequent reporter images. When multiple activation pulses are defined, the activation/excitation sequences are executed in the order they are defined. The entire sequence is then repeated (see diagram below). The excitation sequences from each activation pulse are saved to their own files to be analyzed independently.

### Multiple Activation Experiment

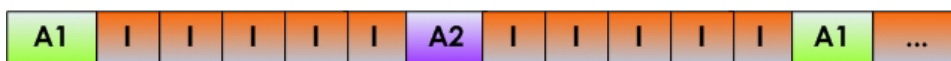

**A1** = First Activation Pulse [Ex Wavelength, Power, Duration] {568 Laser}  
**A2** = Second Activation Pulse [Ex Wavelength, Power, Duration] {405 Laser}  
**I** = Imaging of Reporter [Ex and Em Wavelengths, ND, nFrames] {642 Laser / Cy5 TIRF}

To set up a localization experiment, the user begins by identifying the imaging laser conditions including:

- Laser power
- Exposure time
- Emission filter
- TIRF depth

From Resolve3D, the user can elect whether the reporter imaging channel is illuminating the sample for the duration of the experiment (Continuous Illumination) or if it is shuttered for each exposure.

Once the reporter imaging conditions are established, the user then defines the appropriate activation/excitation sequence. This begins with the activation laser power and pulse duration. Typically, an experiment will begin with low activation laser power and build as the experiment progresses. For each activation pulse, the user specifies how many reporter images will follow.

During activation/excitation sequence repetition, UltimateFocus can be used to maintain sample focus. The UltimateFocus correction frequency is in units of activation/excitation sequences. Every  $n$  sequences, UltimateFocus samples the z-drift and determines whether the sample has moved more than the move threshold. If the drift is greater than the move threshold, the stage is moved in z to bring the sample back into focus. This z-drift correction can be measured multiple times during an Ultimate Focus event to correct for larger stage drifts.

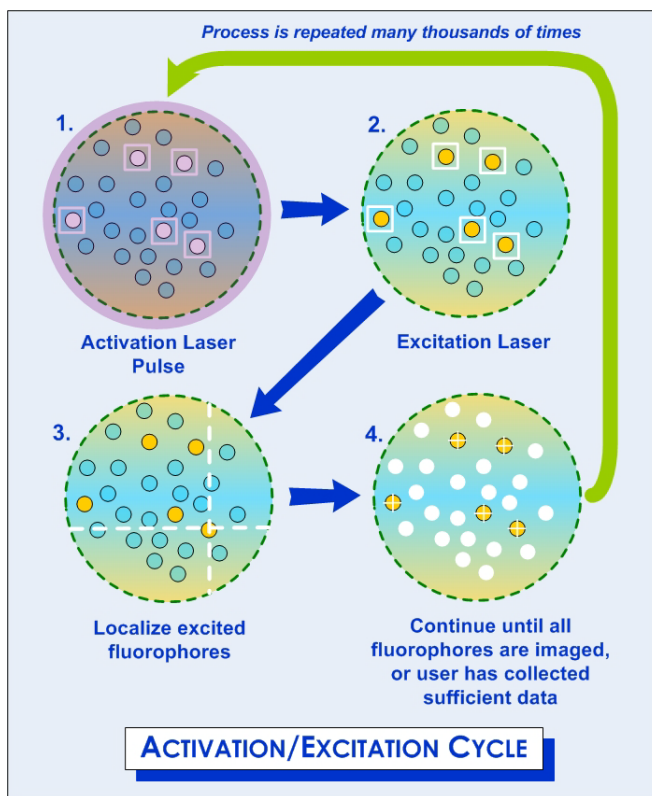
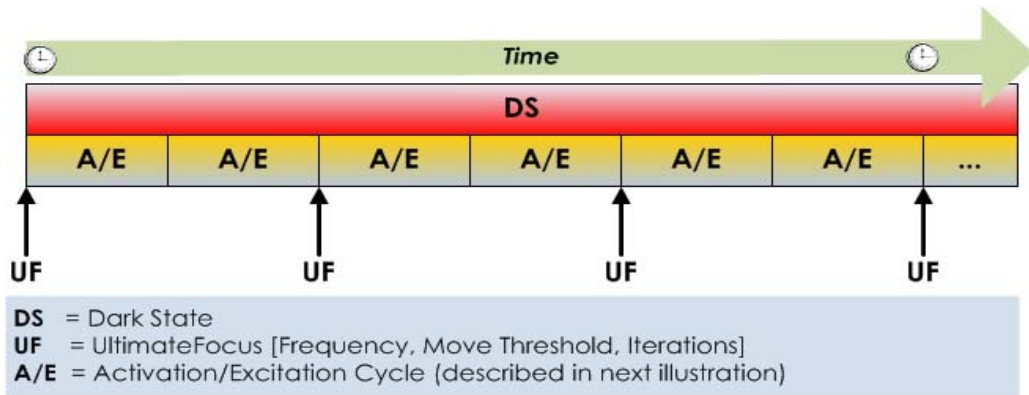

The results of a localization experiment are single-z (2D) time-lapse DeltaVision files (i.e. a movie) where each file contains the reporter images collected after a specific activation pulse.

Additional fluorescent probes for localization microscopy are being developed continuously. These new fluorophores are being optimized for blinking properties, color spectrum, switching cycles and high contrast in the fluorophore's "on" state in comparison to the "off" state. Localization precision for each fluorophore depends on a few factors including the number of photons emitted by the fluorophore (with larger numbers leading to higher localization precision), ability to perform lateral drift correct, and flexibility in the linker used to attach the fluorophore to the protein of interest.

Background noise in super-resolution specimens is caused by natural or “transfection reagent-induced” autofluorescence, as well as by residual fluorescence from surrounding probes that have entered the dark state. Because of this, the fluorescent molecules employed in localization microscopy should display a high contrast ratio (or dynamic range). The contrast ratio is defined as the ratio of fluorescence before and after photo-activation.

## Dense Stochastic Sampling Imaging (DSSI)

Typically, conventional low-density localization microscopy algorithms require that the fluorophores observed in the same frame must be separated by at least a few pixels in order to accurately determine the X-Y coordinates. Using GE's Dense Stochastic Sampling Imaging (DSSI) algorithm, this limitation is no longer a factor. Data that was previously discarded because the fluorophores were too close together, or overlapping, can now be used in the final image reconstruction.

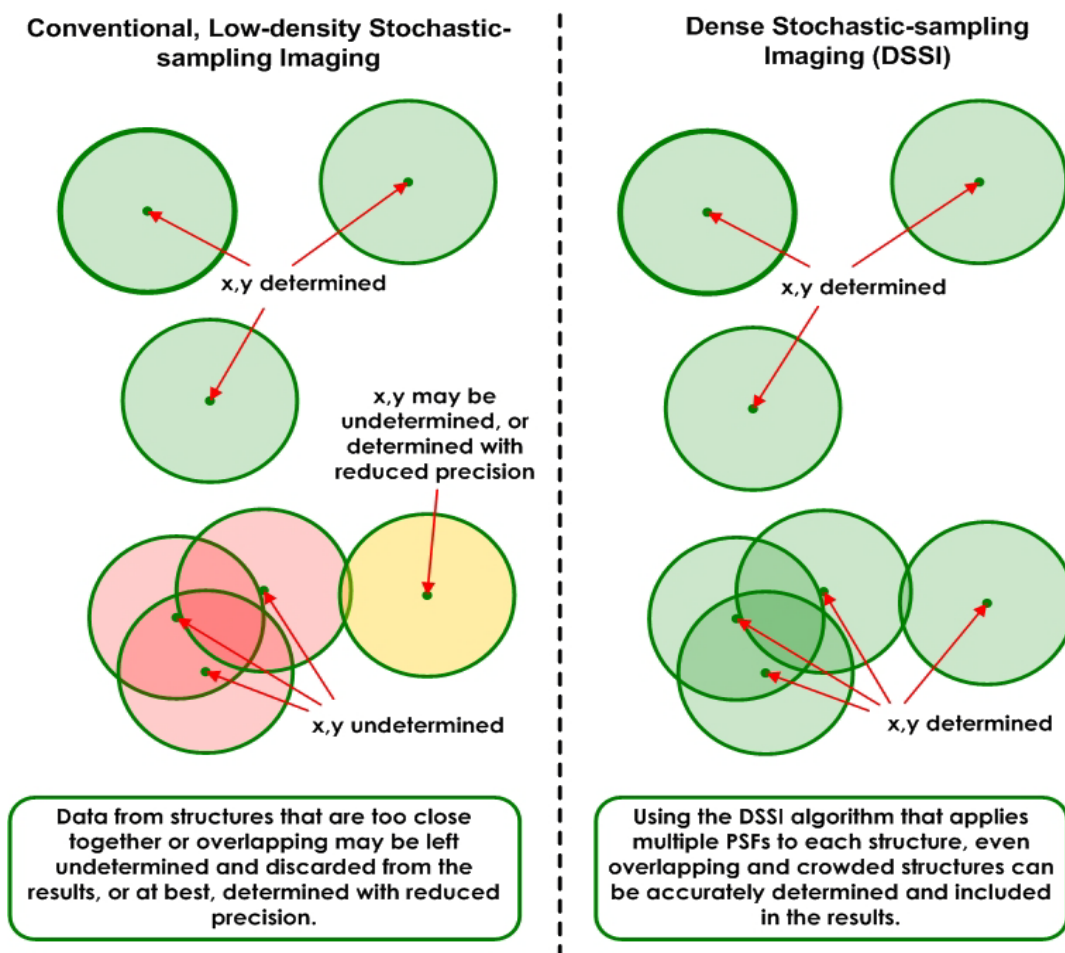

Rather than discarding data produced from overlapping fluorophores, the algorithms used in DSSI have the ability to examine the data more closely by iteratively attempting to fit multiple Gaussians to overlapping or densely labeled fluorophores.



The localization experiment results in a very large table of numbers representing X-Y locations, the duration of each fluorophores' signature over time (ie. the number of frames for which the observed molecule persists), and the statistical uncertainty of each fluorophores' fit. This data is used to reconstruct a final image where each fluorophores' location is plotted either as a single X-Y coordinate, or as a single Gaussian with the width given by the localization precision of the fluorophore (the uncertainty of each fit).



**Note** The DSSI localization algorithm is designed to operate with high-density localization data and is restricted from producing localization output from low-density localization data.

---

## Acquiring Localization Images

Use the tools available in softWoRx 6.0 (or later) to acquire images for localization experiments.



**Note** Localization data acquired on DeltaVision imaging systems is intended for analysis specifically with the softWoRx software. Export of data for analysis using third-party localization software may require license to relevant intellectual property in the field of Localization Microscopy.

---

## Before Starting a Localization Experiment

Before you begin any localization experiments, it is essential that you understand how to use the DeltaVision system's Beam Concentrator as well as properly calibrate the camera with which you plan to generate the localization images. The following two subsections are provided to assist you with these tasks.

### Using the Beam Concentrator

Maximum signal-to-noise ratio will be achieved when fluorophores switch on and then off again within a single image frame. Higher TIRF laser power density leads to more efficient photoconversion, allowing for effective switching with shorter exposure times. The Beam Concentrator can be used to increase the TIRF laser power density reaching the sample.



**Note** Using the Beam Concentrator limits your usable field of view to 512x512 pixels.

---

To use the Beam Concentrator, navigate to **Resolve3D | Settings | Lasers | TIRF Settings** and select the check box for "Use TIRF Beam Concentrator," then proceed to set up TIRF imaging as described in the "Imaging Using TIRF" section in Chapter 7 of the [DeltaVision Imaging System User's Manual](#).

### Calibrating the Camera for Localization Imaging

When comparing localization microscopy data between imaging platforms it is often convenient to express the data in terms of absolute quantities, such as photons, rather than raw units obtained from the camera. DeltaVision provides a method for accurately measuring a digital camera's conversion factor in units of photoelectrons per Analog-to-Digital Unit ( $e^-/ADU$ ). This measurement, along with the camera's quantum efficiency (at the wavelength used in the experiment), is used to express image intensity in terms of absolute photons instead of arbitrary intensity counts.

The measurement protocol and algorithms used are derived from European Machine Vision Association standard EMVA1288 (reference: <http://en.wikipedia.org/wiki/EMVA1288>).

The protocol involves collecting images at a number of discrete incident light intensity levels that are chosen to represent a range from dark current to an intensity that causes near full-well saturation of the camera's detector.

The measurement tool is available from the Resolve3D Calibration menu or Resolve3D Settings | **Imaging** tab. Follow the steps in the Measure Camera e<sup>-</sup>/ADU Conversion Factor window to obtain a final e<sup>-</sup>/ADU conversion. The result is displayed at the bottom of the window. This value is saved and used for further localization data analysis.

The e<sup>-</sup>/ADU conversion factor is dependent on the camera and the camera gain settings used for imaging. For instance, if the user changes their camera from a CCD camera to an EMCCD camera, it would be necessary to measure the conversion factor prior to acquiring any localization data. Additionally, if the user changes EMCCD or conventional gain settings, it would be necessary to measure the new e<sup>-</sup>/ADU conversion factor. All conversion factors are saved for each camera according to the desired camera gain setting.

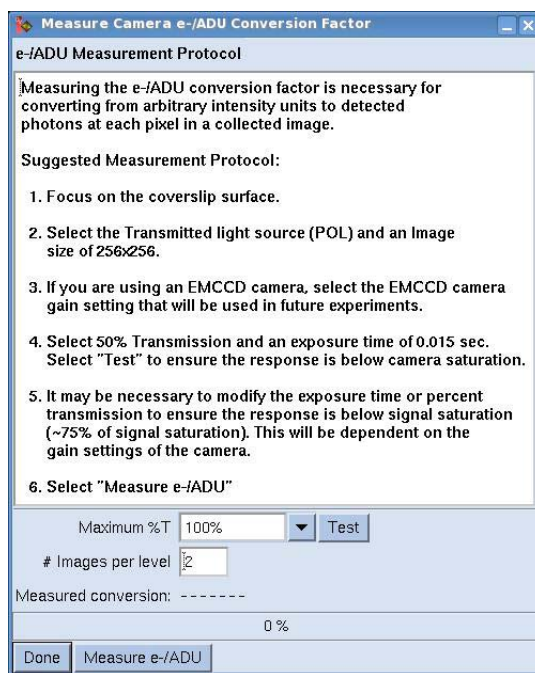

Measure Camera e-/ADU Conversion Factor Window

## Localization Setup

To set up and prepare for a localization experiment:

1. From the Resolve3D window, select **Experiment**. The Design/Run Experiment window is displayed.
2. Select the **Design** tab to activate it.

3. Select the **Localization** tab on the left side of the window. A screen similar to the following is displayed:

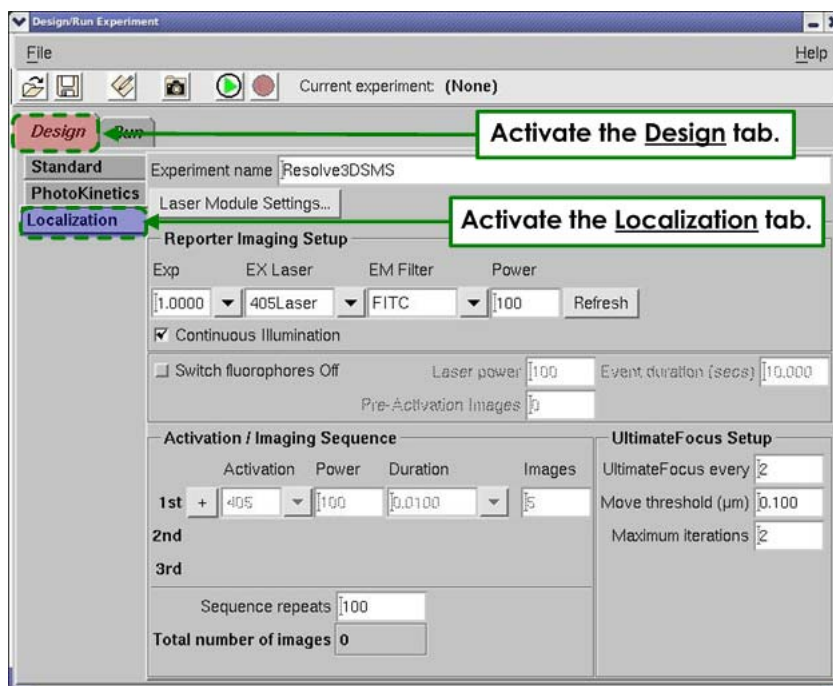

Design/Run Experiment Window - [Design](#) and [Localization](#) tabs active

4. In the **Experiment name** field, you can either accept the default name, or rename the experiment in order to retain the settings for future experiments.
5. Click on the **Laser Module Settings** button. The Resolve3D Settings window is displayed with the **Lasers** tab activated. Use this window and the TIRF Illumination Settings window to set up the DeltaVision system as you normally would to perform a TIRF-based experiment. This procedure is described in the “Imaging Using TIRF” section in Chapter 8 of the [DeltaVision Imaging System User’s Manual](#).



**Note** In the TIRF Illumination Settings window, move the **Laser Path Splitter** slider all the way to the right (for **100% TIRF**).

6. In the Reporter Imaging Setup portion of the Design/Run Experiment window, use the drop-down menu in the **Exp** field to set the exposure time. Then enter your selected EX/EM pair using the drop-down menus for the **EX Laser** and the **EM Filter**.



**Note** When you make a selection from the **EX Laser** drop-down list, the rest of the fields in the Reporter Imaging Setup portion of the window are populated automatically with the last values used.

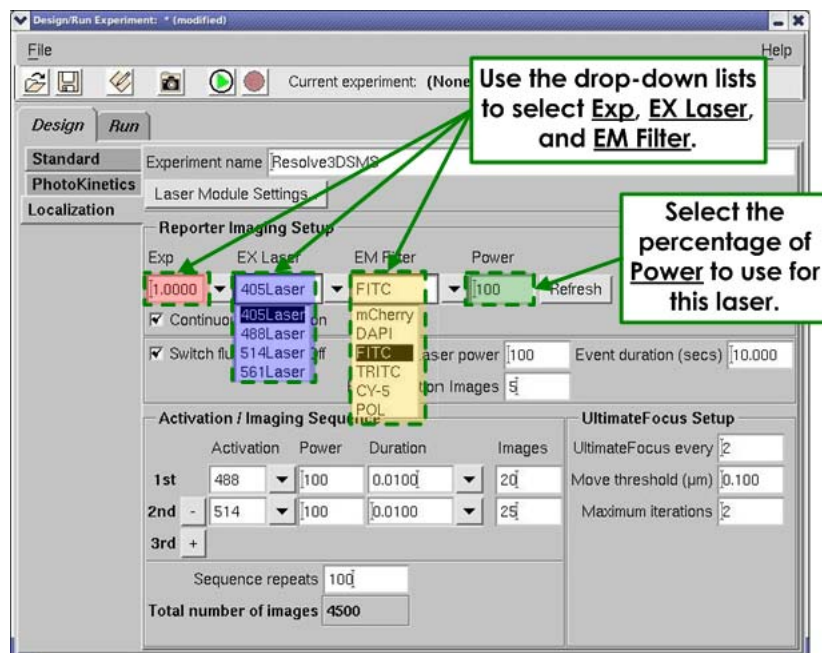

7. To leave the excitation laser turned on throughout the experiment, activate the **Continuous Illumination** check box. Leaving the laser on will help to keep photo-switchable dyes in their “off” states during acquisition so that only a few fluorophores are on in any given frame. Though the photophysics are not completely understood, it may be useful to pulse the excitation laser when using certain fluorophores, such as photo-convertible fluorescent proteins, to help avoid photobleaching or unwanted transitions into triplet states.
8. Activate the **Switch fluorophores Off** check box to use the Reporter Imaging laser to switch all fluorophores to an “off” state before the first activation. With this check box activated, you can adjust the **Laser power**, **Pre-Activation Images**, and **Event duration (secs)** fields as desired.



**Note** Pre-activation images are used to confirm that the majority of the fluorophores have been switched to the “off” position.

In some cases, it may be useful to initially switch the fluorophores to an “off” state prior to data acquisition. This can be very useful when dyes have been used for labeling. The user must be careful not to subject the sample to an excessively long

pulse duration, which could photobleach the sample. It may be necessary to empirically determine the optimal duration for each sample type.

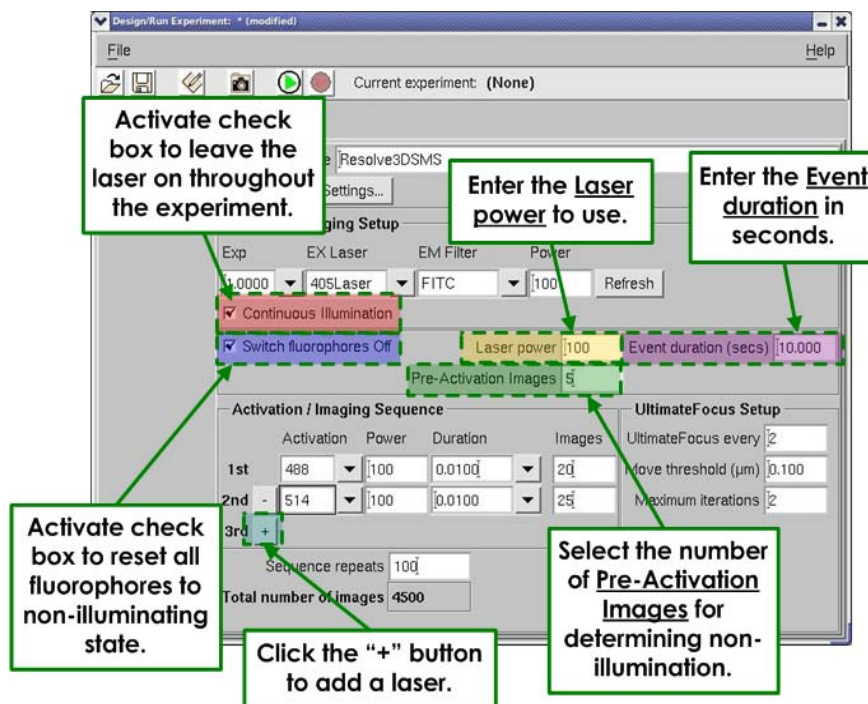

9. In the Activation/Imaging Sequence portion of the Design/Run Experiment window, use the drop-down list in the **Activation** field to select each laser wavelength (up to three lasers) for the activation laser(s). To the left of the **Activation** field, click the + button to add another laser or click the - button to remove a laser.
10. In the **Power** field, enter the percent of laser power to use for this wavelength. This field should be set at a minimum of 10% for laser stability.
11. In the **Duration** field, use the drop-down menu to select the duration for each laser pulse.



**Note** If you have the **Continuous Illumination** check box activated, you cannot set the duration for any of the activation lasers to **Continuous**.

12. In the **Sequence repeats** field, enter the number of times you want to repeat the entire sequence.
13. Use the settings in the UltimateFocus Setup portion of the window to set up UltimateFocus for the experiment. Enter your selection for how often you want UltimateFocus to perform a z-focus maintenance correction in the **UltimateFocus every** field. This is the number of sequences to wait before performing UltimateFocus.
14. In the **Move threshold (μm)** field, enter your selection for the move threshold. Any drift greater than the value set in this field is corrected.
15. In the **Maximum iterations** field, enter the maximum number of iterations for UltimateFocus. This selection represents the maximum number of times the

UltimateFocus function will be performed to find optimal focus during a single correction event.

The screenshot shows the 'Design/Run Experiment' window with the 'Localization' tab selected. The window title is 'Design/Run Experiment: \* (modified)'. The 'Standard' tab shows 'Experiment name: Resolve3DSMS'. The 'PhotoKinetics' tab shows 'Laser Module Settings...'. The 'Localization' tab has several sections:

- Exp:** [1.0] [Refresh]
- Continuous illumination:**
- Switch fluorophores On:**  Laser power: [100] Event duration (secs): [10.000]
- Pre-Activation Images:** [5]
- Activation / Imaging Sequence:**

	Activation	Power	Duration	Images
1st	488	100	0.0100	20
2nd	514	100	0.0100	25
3rd	+			
- UltimateFocus Setup:**
  - UltimateFocus every: [2]
  - Move threshold (µm): [0.100]
  - Maximum iterations: [2]
- Sequence repeats:** [100]
- Total number of images:** 4500

Callouts in the image provide instructions:

- Use the drop-down lists to select Activation and Duration for each laser.** (Points to the Activation and Duration columns in the table)
- Select the percentage of Power to use for each laser.** (Points to the Power column in the table)
- Select the number of times to repeat the entire sequence.** (Points to the Sequence repeats field)
- Select the number of Images for each activation.** (Points to the Images column in the table)
- Select the UltimateFocus options for this experiment.** (Points to the UltimateFocus Setup section)

## Running a Localization Imaging Experiment

To run a previously configured localization experiment:

1. To start the localization experiment, select the **Run** tab on the Design/Run experiment window.
2. In the **Image file name** field, enter a file name for the image that will be generated by this experiment.
3. In the **Image title** field, optionally enter a title or label to put in the image file header.
4. In the **Add note to log** field, you can optionally enter any text for a note to be added to the experiment log file.

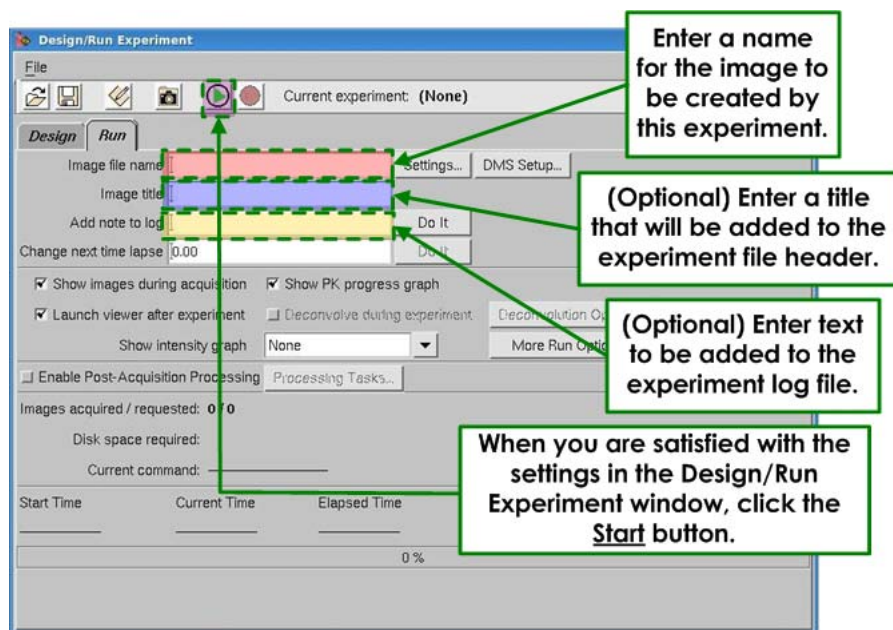

5. Activate the **Show images during acquisition** check box to view preview images in the Data Collection window during acquisition.
6. Activate the **Launch viewer after experiment** check box to view the resulting image in an image window after the experiment is finished.

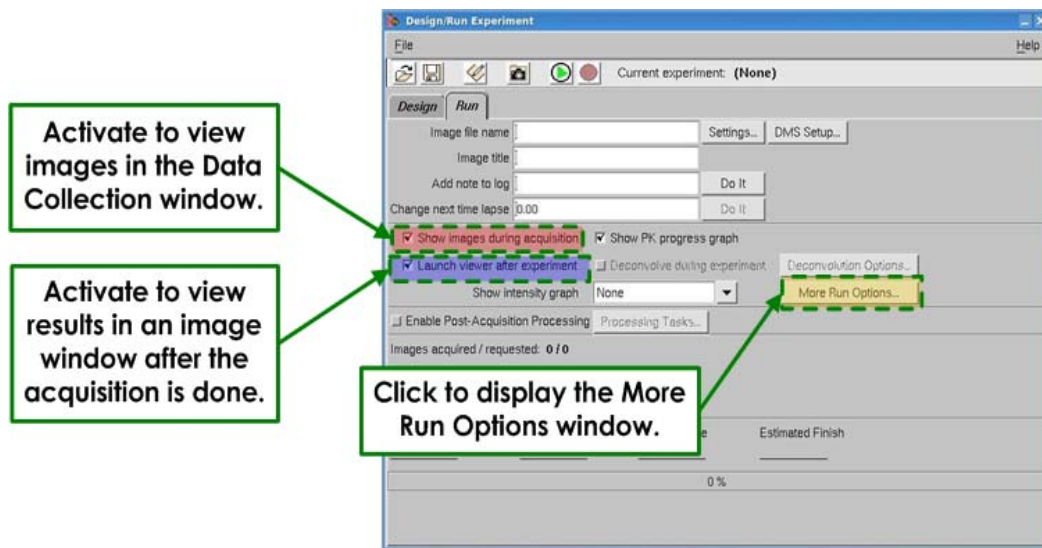

7. Click the **More Run Options** button. The More Run Options window is displayed.

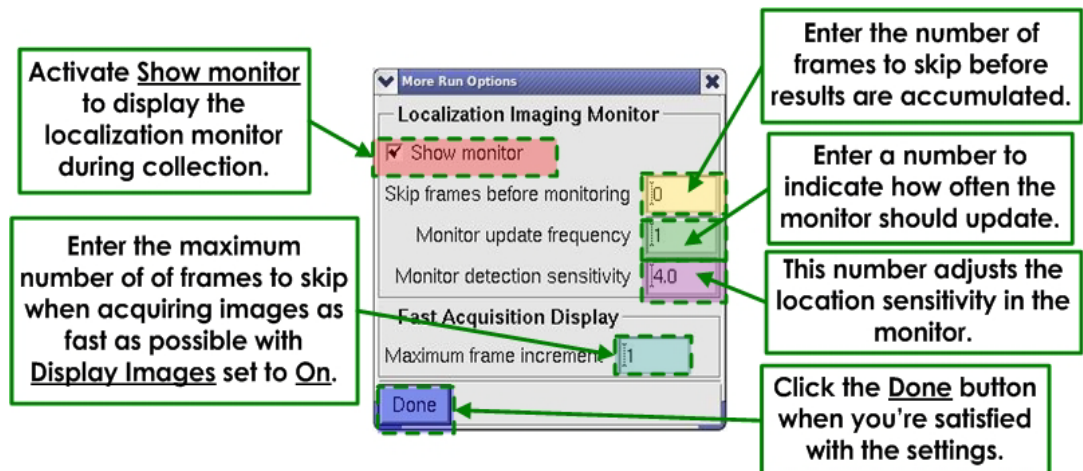

8. From the More Run Options window, activate the **Show monitor** check box to display the Localization Imaging Monitor during the collection process.
9. In the **Skip frames before monitoring** field, enter the number of frames to skip before any results are collected.
10. In the **Monitor update frequency** field, enter the frequency at which the localization monitor should update.
11. In the **Monitor detection sensitivity** field, adjust the location sensitivity for the localization monitor.
12. In the **Maximum frame increment** field, enter the maximum number of frames to skip when you are acquiring images as fast as possible with **Display Images** set to **On**.
13. Click on the green **Start** button at the top of the Design/Run Experiment window. The Activation Power/Duration window is displayed.

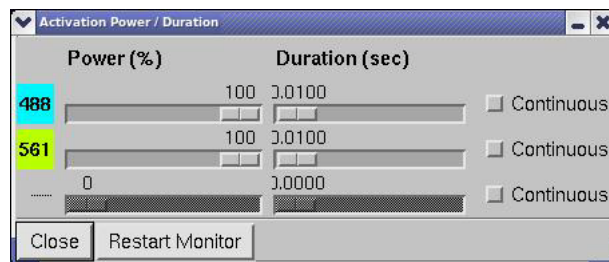

14. At this point, the researcher will visually inspect the data. The sample should be exhibiting some blinking or photoswitching. If there are too many fluorophores "on" (i.e. multiple fluorophores in a single diffraction limited spot, or adjacent spots), then you should wait until only a few fluorophores in each frame are observed before increasing the activation laser power.
15. From the Activation Power/Duration window, use the **Power (%)** sliders to adjust the percentage of power to use for each laser. This is used to control the blinking and should only be adjusted if (1) the fluorophore can be activated, and (2) the number of fluorophores on in a field of view is very sparse.



16. From the Activation Power/Duration window, use the **Duration (sec)** sliders to adjust the length of time (in seconds) that a pulse from each laser will last.
17. Use the **Restart Monitor** button to reset the Localization Imaging Progress Monitor window back to zero. The visualization resets back to zero and then continues from there (see illustration below).

The progress monitor shows a super-resolution representation of the data. This representation is designed to give the user a guideline as to when enough data has been obtained. It finds all the peaks using a centroid algorithm and plots each peak as a single pixel in the image. The more times the peak is observed, the more times it will be plotted in the image. This monitor is only a guideline, and the results using the multiple Gaussian fitting routine combined with any additional refinements in the data will alter the image.

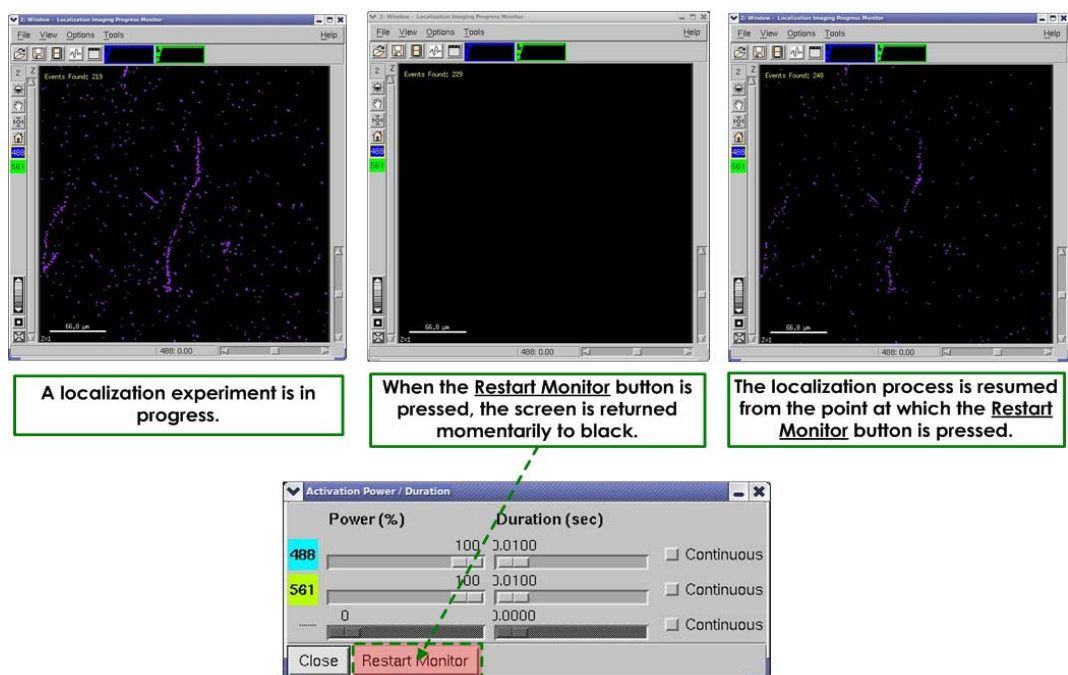

## Using the Localization Progress Monitor

The Localization Progress Monitor displays an approximation of the final image reconstruction based on the current data collected. A fast calculation determines the positions of the fluorophores in each frame in real-time, or near real-time. The progress monitor is only an approximation of the final super-resolution reconstruction. The final data is fit to Gaussian functions in order to obtain a reconstruction with higher localization precision.

For each frame of the acquired data, the Progress Monitor first detects fluorophores with detection sensitivity  $n$  standard deviations above the mean of the raw image. The positions of the detected fluorophores are determined and plotted on the Progress Monitor display. The number of detected fluorophores for the current acquired frame is displayed in the upper-left corner of the Progress Monitor. The Progress Monitor is displayed as an image with 20 nm pixels. The positions of each detected fluorophore are plotted as a single intensity count in the appropriate pixel, leading to a super-resolution

display with localization precision equal to the pixel size (20 nm in this case). Each time additional fluorophores are plotted in the image, the intensity count of those pixels increases, such that bright areas show the locations of where many fluorophores have been detected. If a sufficient amount of data has been collected, the user may elect to end the experiment early. While the experiment is running, the Progress Monitor can be cleared and restarted by clicking the **Restart Monitor** button from the Activation Power/Duration window.

- To adjust the Progress Monitor settings, click on the **More Run Options** button on the Design/Run Experiment window. The More Run Options window is displayed.

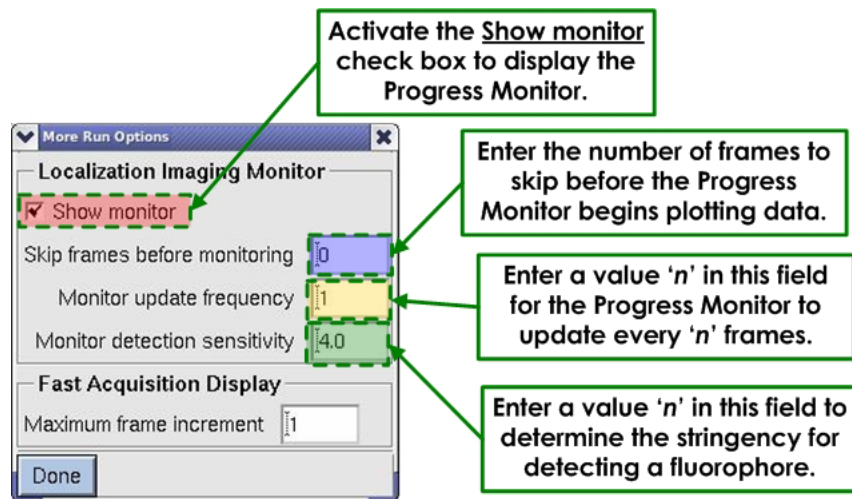

- Select the **Show monitor** check box to display the Localization Progress Monitor.
- In the **Skip frames before monitoring** field, enter an integer number of frames to skip at the beginning of the acquisition before the Progress Monitor begins to plot data. This feature is designed to remove false positives produced from very densely labeled samples, where many of the initially detected fluorophores may not contribute to the final super-resolution reconstruction due to poor localization precision. Depending on the labeling density, it may not be required to skip any frames.
- Enter the value  $n$  in the **Monitor update frequency** field to indicate that the Progress Monitor shall analyze every  $n$  frames of the experiment.
- In the **Monitor detection sensitivity** field, enter an integer value,  $n$ , to determine the stringency for detecting a fluorophore. Fluorophores exhibiting counts that are  $n$  standard deviations above the mean intensity of the raw image are detected and plotted on the Progress Monitor.

### During Acquisition

The user can update the **Monitor update frequency** and **Monitor detection sensitivity** fields during acquisition by changing the value and pressing the Enter key on the keyboard.

While a localization experiment is running, the user should monitor the number of excited fluorophores in each frame and determine whether the activation laser requires adjustment. This decision is based upon three inputs:

- The apparent density of fluorophores within the displayed streaming image (typically Image Window 21)
- The number of molecules found as shown in the Progress Monitor
- The overall image in the Progress Monitor

Low densities of excited fluorophores within a field of view will generally be represented in the Progress Monitor as very few detected fluorophores per frame with minimal apparent change to the Progress Monitor image over time. Many excited fluorophores will generally be represented as a high number of detected fluorophores per frame and significant change to the Progress Monitor image over time. In these cases, it may be necessary to increase or decrease the activation laser power or duration using the controls in the Activation Power/Duration window.



**Note** It is important to tune the activation power based on the expected fluorophore switching characteristics of the sample.

---



## 7. Data Collection Techniques

---

This chapter provides guidance and suggestions for:

- Finding a Specimen and Recording its Position
- Finding Exposure Times
- Using Köhler and Critical Illumination
- Monitoring Data Acquisition
- Editing Experiment Macros

### Finding a Specimen and Recording its Slide Holder Position

Recording the position of your slide is useful when you are conducting a point visiting experiment and you need to remove the slide before you are finished. Use the following instructions to find a sample and record its position on the slide with the Repeatable Slide Holder. When you resume your experiment, you can place the slide in the position that you recorded.

**To find and center the specimen:**

1. Choose the objective by rotating the objective turret. Be sure to select the same objective in the Resolve3D window.



**Note** If you are using an oil immersion lens, you must apply immersion oil to the sample. See Appendix A: The Oil Immersion Kit, for more information about the oil calculator.

- Secure the slide. Since *DeltaVision* is an inverted microscope, the sample must be placed with the cover slip facing down toward the objective. If you are using a standard microscope slide (1" x 3" or 25 mm x 75 mm), you can use the Repeatable Slide Holder to hold the slide. To do this, pull the return spring to the left and place the slide cover slip down onto the Repeatable Slide Holder so that the upper right corner is pressed laterally against the brass locators (shown as **A** and **B** in the figure below) and the upper left edge is pressed laterally against the brass locator **C**. Then gently release the return spring to secure the slide. Lightly push down on the slide to make sure that it is fully seated in the holder.

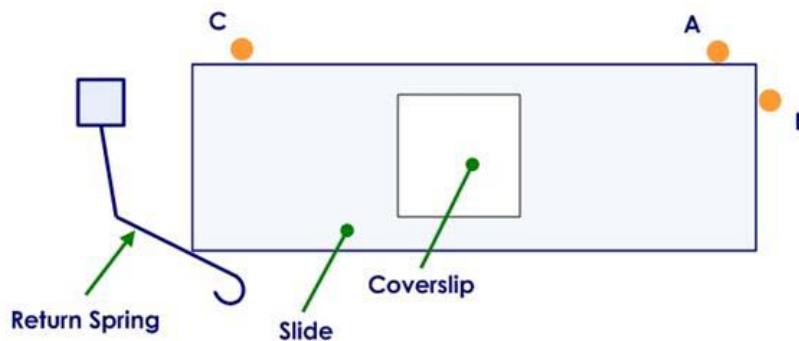

Repeatable Slide Holder



**Note** When you remove a slide from the Repeatable Slide Holder, be sure to make note of the slide orientation in the holder.

- Use the Coarse Focus knob to raise the objective.
- Select the desired eyepiece (EP) filter.
- Select the desired excitation (EX), neutral density (%T), and emission (EM) filters.
- Rotate the Port Selector at the base of the microscope to direct the light collected by the objective to the Eyepiece (◀).
- To use the transmitted light to locate the specimen, open the transmitted light shutter by pressing TRANS SHUTTER on the keypad. This allows white light to transilluminate the sample. (The intensity for the transmitted light is controlled using the **%T** field in the Resolve3D window.)

Alternatively, open the EX shutter and find the desired focal plane optically using either the focus knobs on the microscope or the Resolve3D Z stage controls.



**Note** When you are sitting in front of the microscope, rotate the top of the microscope's focus knob toward you to move the objective up. Rotate the top of the microscope's focus knob away from you to move the objective down.

8. Use one of the following methods to maneuver the slide and find an area of interest:

#### Keypad

The buttons on the keypad are used for movement in the X, Y, and Z directions. Using the arrow keys on the keypad causes the stage to move by steps. The size of each step is doubled each time the STEP INCREASE button is pressed and halved each time the STEP DECREASE button is pressed. By adjusting the step size to the frame size, you can create a condition where each press of a step arrow will move the sample one frame. This is a convenient way to scan a large area for rare events (e.g., mitosis). Since the step movements are rapid, using the arrow keys in this way can be much less fatiguing than using the joystick.

#### Joystick

The joystick controls stage movement in the X and Y directions. Set the stage speed using the keypad SLOW, MEDIUM, or FAST buttons. MEDIUM is typically the best speed to start with. These buttons control the stage speed when you are using the joystick to move the stage.

#### Workstation

The Resolve3D module allows you to finely control stage motion. The arrow buttons move the stage in discrete increments that are indicated by the values in the **dX**, **dY**, and **dZ** text boxes. Resolve3D provides the only mechanism from which to obtain discrete step sizes.



**CAUTION!** To record and maintain accurate stage coordinates, focus by moving the stage with the Resolve3D controls instead of using the focus knobs to move the objective. Resolve3D cannot track the movement of the objective.

9. Tighten the Focus Lock on the left side of the focusing knob (see “Focusing” on page 3.3).
10. Use one of the methods from Step 8 to find the approximate center of the specimen and place it in the center of the field of view.
11. Direct light to the camera port using the Port Selector knob on the microscope base.
12. If you want to repeat the experiment using the same slide, record the position of the slide on the Position Indicator (the letter scale at the bottom of the Repeatable Slide Holder).

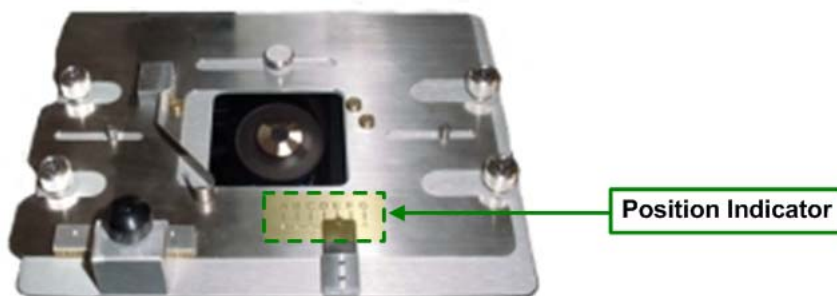

## Finding Exposure Times

The exposure time correlates the signal intensity level for the image acquisition. Finding the appropriate exposure time for each channel in an experiment is crucial to acquiring the best image data. Many factors must be considered. Although you want to see the maximum intensity in each wavelength, you must not saturate the camera or photo-bleach your sample.

High-Speed CCD Camera saturation occurs when the intensity values reach 4095 counts. The 12-bit High-Speed camera has an intensity range of 0 to 4095 counts. (The EMCCD 16-bit High-Speed camera has an intensity range of 0 to 65535 counts.) For successful deconvolution, a minimum intensity of 50 counts above background is recommended.





**Note** For live cell imaging, cells tolerate shorter exposures better than longer exposures, even at increased illumination intensity.

---

The response of increasing the exposure time is roughly linear. Therefore, if an exposure time of 0.2 sec results in a maximum intensity level of 1000 counts above background, then an exposure time of 0.4 sec will result in a maximum intensity level of approximately 2000 counts.

Use the following instructions to find the best exposure time for each excitation wavelength. This procedure should be performed for each excitation wavelength used in the experiment.

### To find exposure time:

1. From the Resolve3D window, set the neutral density filter (in the **%T** field) to 100%. (For live cells, set this field to 10%.)
2. Set the exposure time to a low value. (0.5 seconds is recommended for live cell experiments.)
3. The **dZ** field represents the step size in microns.
  - Click in the **dZ** field.
  - Enter the desired value for the Z step.
4. Move through the area of interest by pressing  and  in the Stage window portion of the Resolve3D window to move the stage in the Z direction.
5. Click the **Acquire** button.
6. Continue performing Steps 4 and 5 to obtain a sampling of Z sections. Find the maximum intensity in these sample images by observing the value of the **Max** field in the Resolve3D window. Typically, the focal plane with the highest maximum intensity value is the plane of optimal focus.
7. Move to the plane of optimal focus. This is the Z section with the highest intensity value.
8. From the Resolve3D window, choose **View | Point List**.
9. Click **Mark Point** to record its position.
10. Increase exposure time, but consider the amount of exposure the specimen can tolerate. Intensity values increase in direct proportion to exposure time.





**Note** There could be a higher intensity value in the image data that you did not sample. Therefore, do not set the exposure time to the limits of the sampled data because a higher intensity, un-sampled plane may saturate the camera.  
For fixed cell experiments, **Max** should be 50 – 60% of the saturation value. For live cell experiments, **Max** should be 2 – 3 times the Min (background).

11. Repeat Step 10 for all desired wavelengths.

## Using Köhler and Critical Illumination

*DeltaVision* allows you to easily switch between two types of illumination:

- **Köhler Illumination** is the most commonly used form of illumination. It provides very even specimen illumination across the field-of-view. The light uniformly drops off as the distance from the focal plane increases.
- **Critical Illumination** directs the entire light source to the size of the detected area, and not the entire sample. With Critical Illumination, more light is directed to the focal plane and the out-of-focus light drops off more rapidly than in Köhler Illumination, based on the size of the field-of-view. Critical illumination also provides better axial (Z) and lateral (X,Y) contrast.

## Köhler/Critical Switching with API FI

If your *DeltaVision* system is using the Applied Precision Fluorescence Illuminator (API FI), use the following procedure to switch between Köhler and Critical illumination:

- On the Resolve3D main menu, click **Settings** and then select the **Illumination** tab.

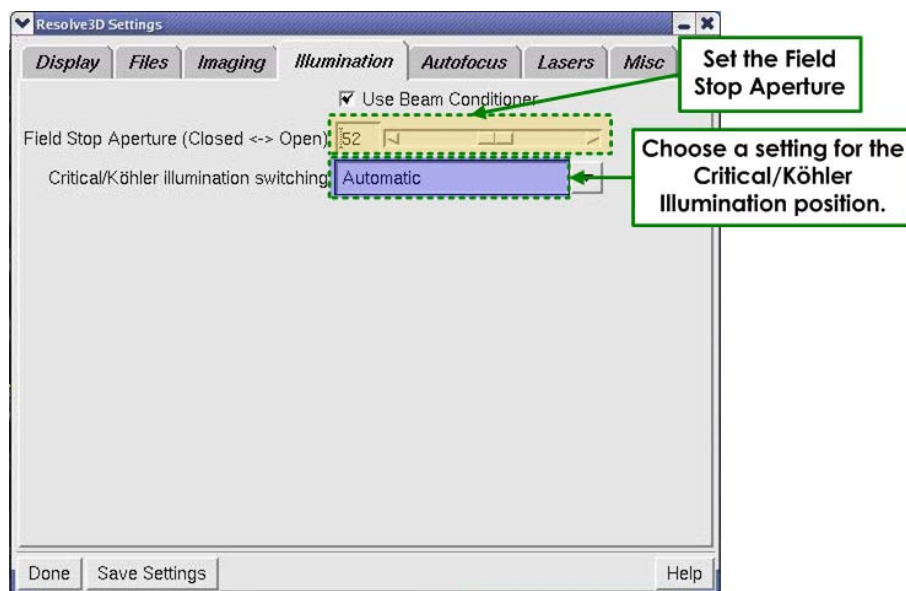

### Field Stop Aperture (Closed <-> Open)

This field allows you to set the field stop aperture to **Closed**, **Open**, or any percentage in between. You can either enter a percentage in the field or use the slider to set the percentage.



**Note** When the setting is set to **Closed**, the field stop aperture is about 20µm in diameter.

---

### Critical/Köhler Illumination Switching

On an Applied Precision Fluorescence Illumination Module, there are three choices for the motorized Critical/Köhler illumination position:

- **Automatic** – *DeltaVision* automatically adjusts the position of the critical/Köhler illumination when the EX shutter is opened using the keypad (typically when the eyepieces are being used). The position is automatically returned to critical illumination when an image is requested, either via Resolve3D or by running an experiment.
- **Always Critical** – *DeltaVision* moves the critical/Köhler motor to critical illumination and leaves it in its position regardless of the current shutter states.
- **Always Köhler** – *DeltaVision* moves the critical/Köhler motor to Köhler illumination and leaves it in its position regardless of any new image requests or experiments running.

### Köhler/Critical Switching with Olympus FI

If your *DeltaVision* system is using an Olympus Fluorescence Illuminator, you'll use the *DeltaVision* system's Fiber Optic Module (FOM) to align the light path from the fiber optic cable to the fluorescence illuminator. This module allows you to adjust the tilt, horizontal, and vertical orientation of the light path.

**To switch to Critical Illumination:**

- Loosen the Locking Knob on the FOM and pull the Focus Control back (away from the stand) until it snaps into place in the Critical Illumination position. Then tighten the Locking Knob.

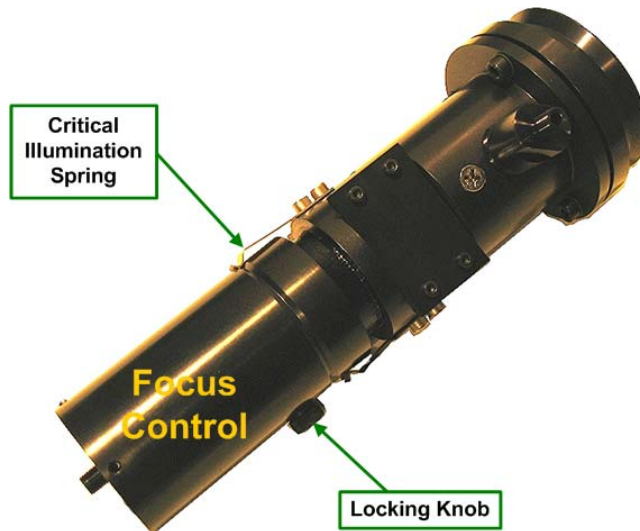

The FOM in Critical Illumination position, the Focus Control is extended so that the Critical Spring is in the groove.



**CAUTION!** When you are adjusting the Fiber Optic Module, be careful not to disconnect the Fiber Optic cable or to bend it in a diameter that is less than 24 inches.

---

**To switch to Köhler Illumination:**

- Loosen the Locking Knob on the FOM and push the Focus Control toward the stand until it snaps into place in the Köhler Illumination position. Then tighten the Locking Knob.



The FOM in the Köhler Illumination position, the Fiber Optic Module is pushed in so that the Köhler Illumination Spring is in the groove.

## Monitoring Data Acquisition

You can set options that control how images are displayed as they are acquired.

### Viewing Deconvolved Image Previews

You can use 2D deconvolution to get a more accurate representation of what data will look like after deconvolution.

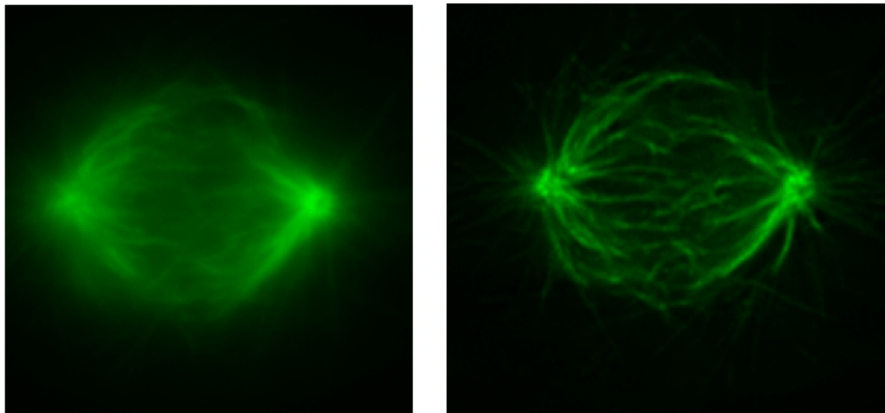

These images show how images are displayed during data acquisition, with and without Real-Time 2D Deconvolution.

**To view previews of deconvolved images:**

1. From the Resolve3D window, click **Settings** to open the Resolve3D Settings window. Then click the **Display** tab.

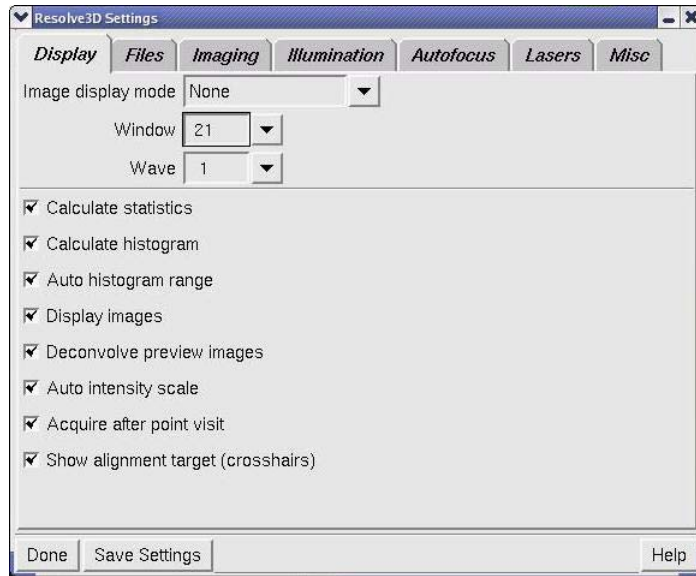

Resolve3D Settings Window | Display Tab

2. Activate the **Deconvolve preview images** check box.



**Note** This option does not provide a full iterative deconvolution, but it allows you to preview images as you collect them.

## Selecting Viewing Modes

You can select from several modes for displaying images in the Data Collection window (or windows) as they are collected. You can choose other modes to display images in color, display each point in a point visiting experiment in a separate window, or to display each channel in a separate window, as shown below.

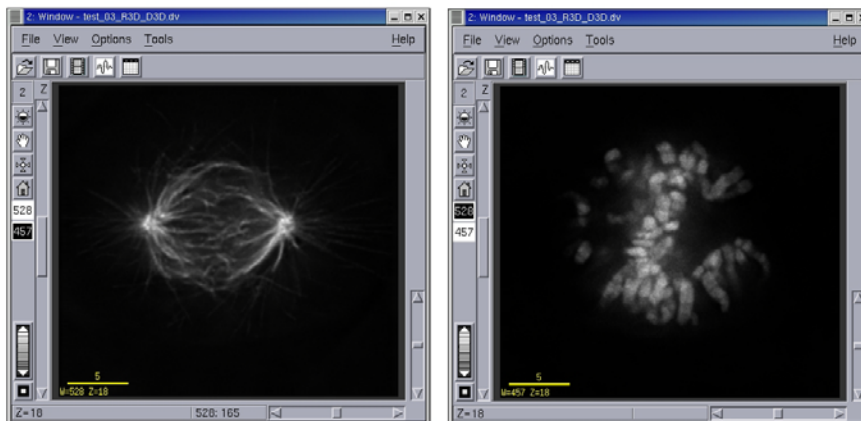

Auto Grayscale mode displays a separate window for each channel.

**To select the display mode:**

1. From the Resolve3D window, click **Settings** to open the Resolve3D Settings window. Then click the **Display** tab.
2. On the **Image display mode** list, select a display mode.

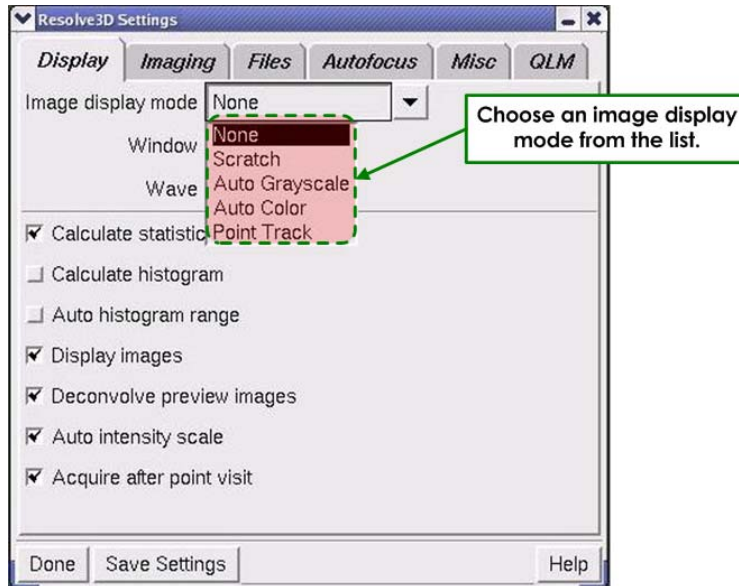

Resolve3D Settings Window

**Image display modes**

Mode	Description
None	Displays images in the current window.
Scratch	Displays all images in the default Data Collection window (Window 21).
Auto Grayscale	Displays images in a separate window for each emission filter.
Auto Color	Displays images in color as they are collected. When using Point Visiting, images are automatically displayed in separate windows for each point. This option should be used only when you are running an experiment.
Point Track	Opens a separate window for each visited point in a point-visiting experiment.

**Displaying Statistics and the Histogram**

You can choose to display statistics and a histogram of the intensity values of each image as it is collected. These values are displayed below the Stage View in the Resolve3D window. The **Min**, **Max**, and **Mean** values are the minimum, maximum, and mean intensity values of the most recently acquired image. The histogram displays the intensity distribution.

**To display statistics and the histogram:**

1. From the Resolve3D window, click **Settings** to open the Resolve3D Settings window.
2. Click the **Display** tab. Then select from the following options.

To	Select
Calculate image intensity statistics	<b>Calculate Statistics.</b> Note: You can improve readout speed by disabling this option.
Calculate and display an image intensity histogram	<b>Calculate histogram</b>
Automatically scale the histogram width for each image that is analyzed.	<b>Auto Histogram Range</b> Note: This option changes only the display of the histogram. It does not change the image data.

## Editing Experiment Macros

The Experiment Macro Editor is used to create or edit Resolve3D experiment macros (command scripts) that control the *DeltaVision* microscope. Most experiment macros are automatically generated using the Design/Run Experiment window, but you may need to create custom macros for certain types of experiments.

The best way to get started is to modify an existing macro with the Experiment Macro Editor. One approach is to use the Design/Run Experiment window to generate a macro and then edit it. Another approach is to use a reference macro.

### To open the Experiment Macro Editor:

1. On the Resolve3D window, click the **Experiment** button.
2. In the Design/Run Experiment window, choose **File | Edit** or the **Edit** button to open the Experiment Macro Editor.

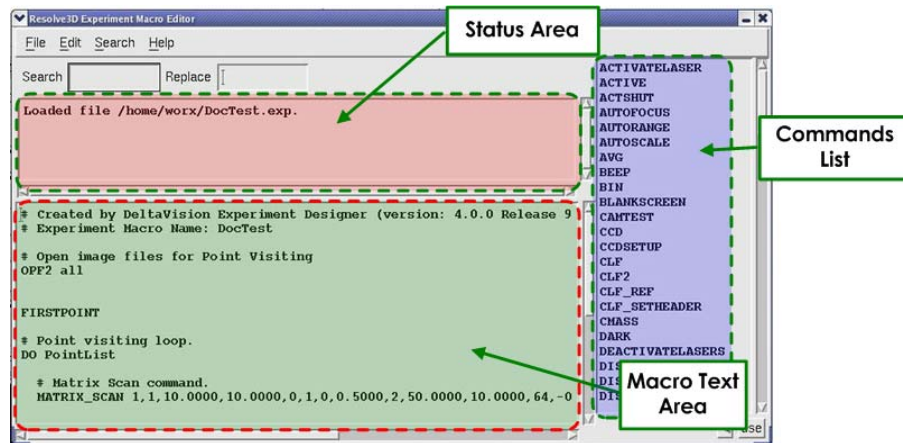

Experiment Macro Editor

### Search & Replace

These text fields are used to specify a search and replace pattern. (You will need to enter strings in these fields before you use the **Search | Replace Text** menu command.)

## Status Area

The text area below the **Search** and **Replace** fields is used by the Macro Editor to provide status and command information.

## Macro Text Area

The Macro Text Area below the Status Area is the main working area of the Macro Editor.

## Commands List

This is the list of available commands. When you highlight a command in the list by clicking it, you are provided with information about the command in the Status Area. If you double-click or select the **Use Item** button below this list, the command is inserted in the Macro Text Area at the current cursor location.

### To edit a reference macro:

1. On the Resolve3D Experiment Macro Editor window, choose **File | Open Reference Macro**. The Open Experiment Macro File window is displayed.

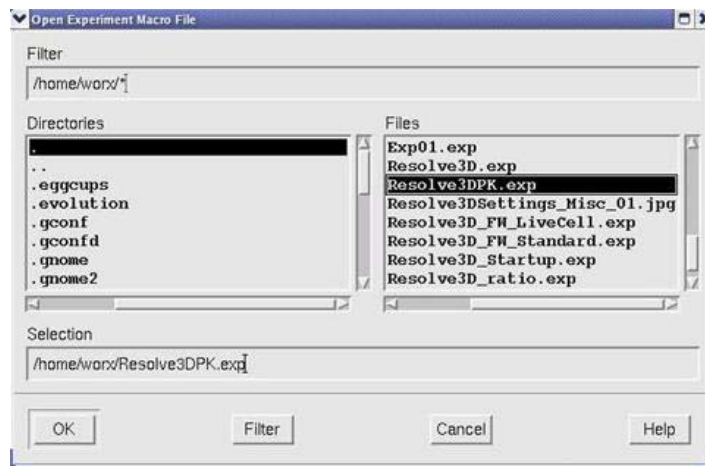

Open Experiment Macro File Window

2. In the Open Experiment Macro File window, select a macro file and click **OK** to open it. The file is opened in the Reference Macro window.



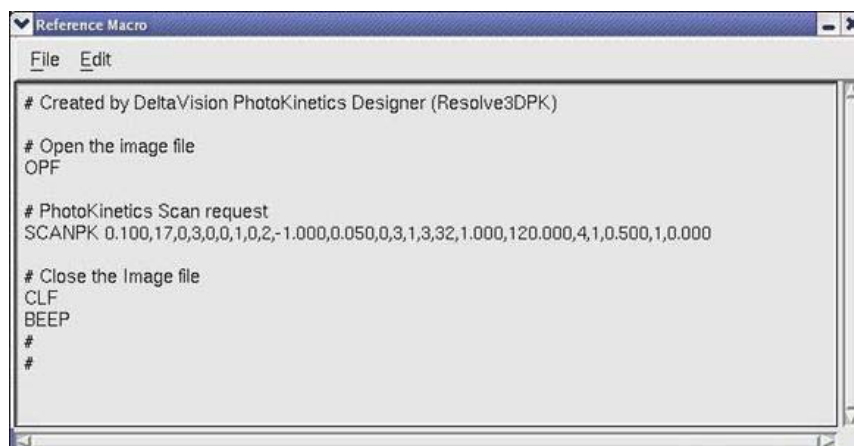

Reference Macro Window

3. Use the mouse to select the part of the reference macro that you want to copy.
4. On the Reference Macro window, choose **Edit | Copy**.
5. On the Resolve3D Experiment Macro Editor, choose **Edit | Paste** to copy the macro into the macro editor.
6. Edit and save the file as a new experiment macro.

## Using Ratio Imaging

*softWoRx* provides a ratio imaging acquisition function that allows you to view a graphic representation of the ratio of two channels as the images are being collected. In addition, a ratio graph displays the mean value (of an area in the middle of the image) vs time. Both the ratio image and the ratio graph are for monitoring purposes only. The ratio imaging experiment results in a two-channel time-lapse image.

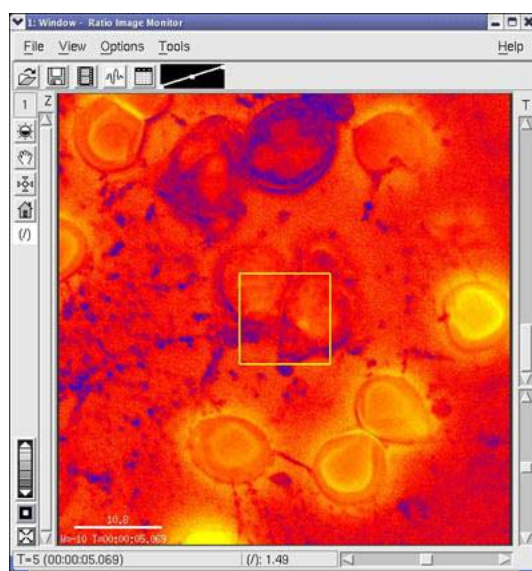

Sample image for ratio imaging experiment

### To set up a ratio imaging experiment:

1. From the *softWoRx* main menu, select **File | Acquire (Resolve3D)** to open the Resolve3D window.
2. On the Resolve3D window, click the **Experiment** icon to open the Design/Run Experiment window. Then, select the **Design** tab.

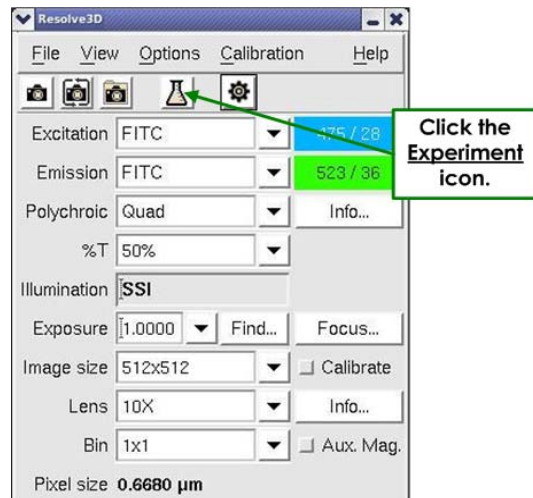

3. Select the **Sectioning** tab and deselect the **Z Sectioning** check box.

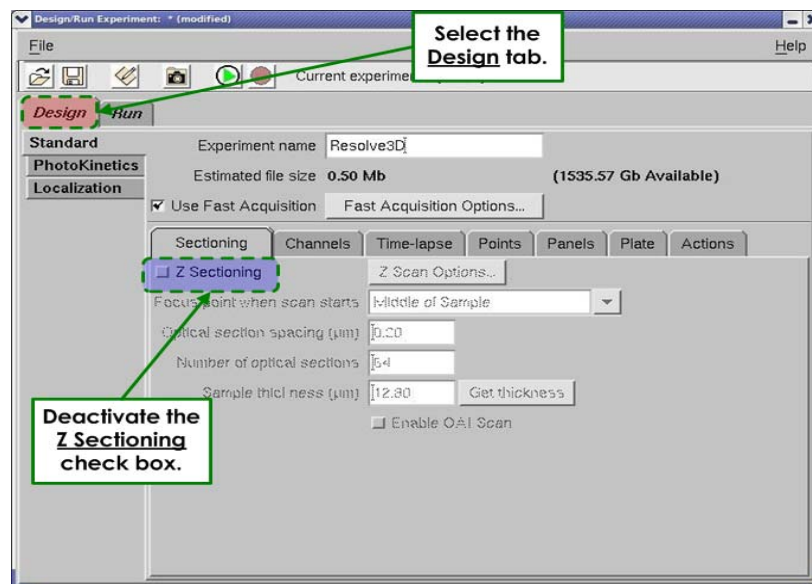

4. Select the **Channels** tab and specify the two channels you want to use for this experiment.

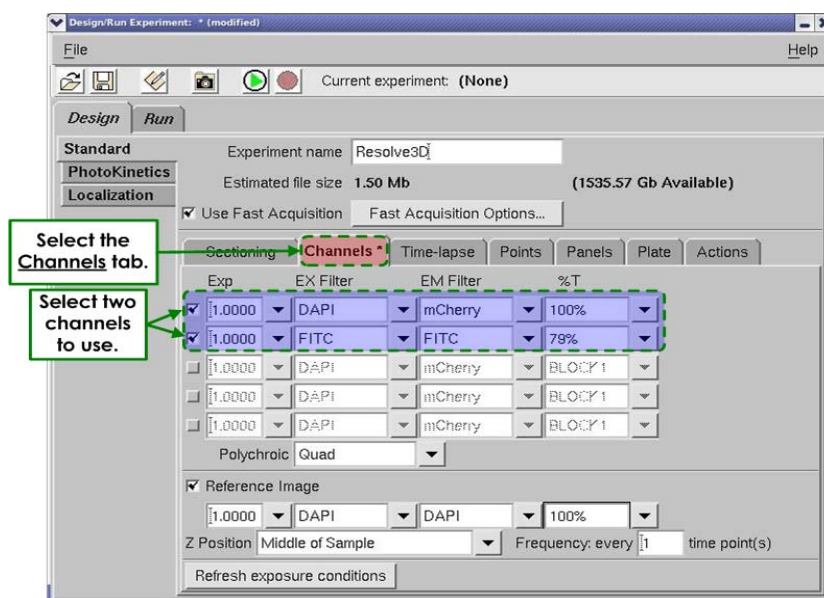

5. Select the **Time-lapse** tab and specify the time-lapse and total time for this experiment.

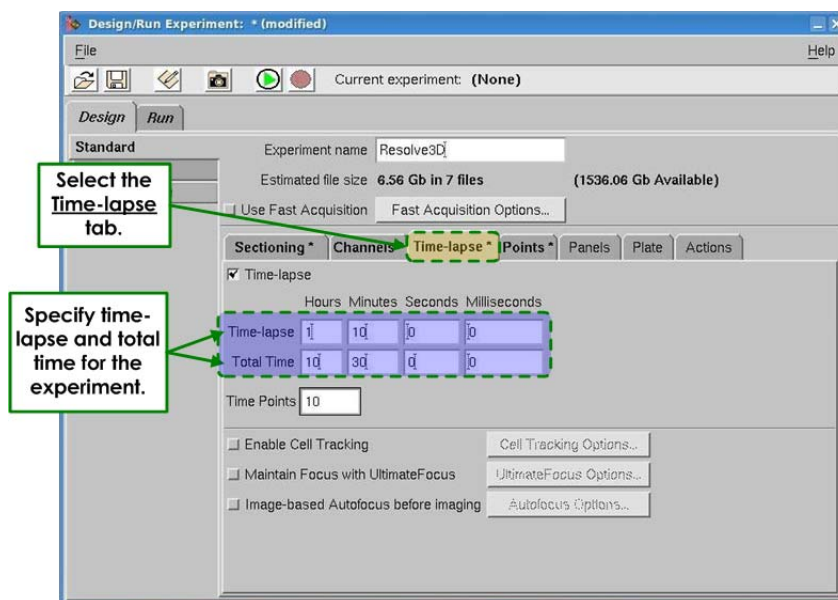

6. Select the **Actions** tab and select **Ratio Image** from the drop-down list of actions for this experiment. The **Time Points** field will default to **all** and the **When** control will be **After Imaging**.

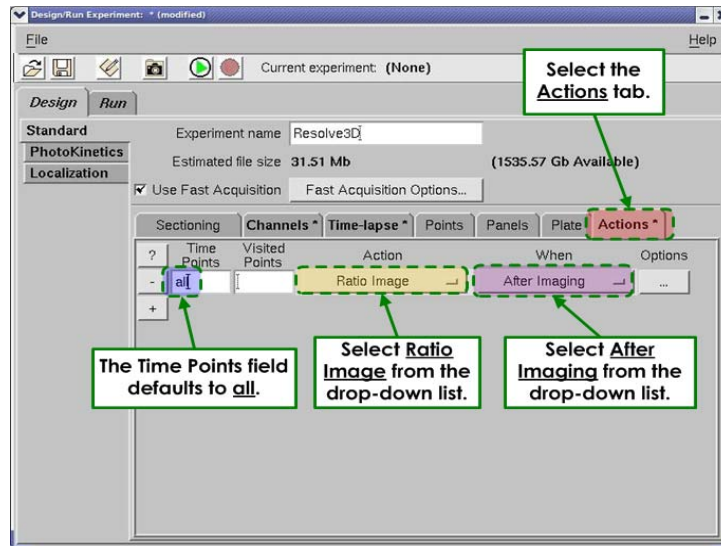

7. Select the **Run** tab and enter the image file name and a title for the ratio image. You can also enter text into the **Add note to log** field to include the text in your image log file.

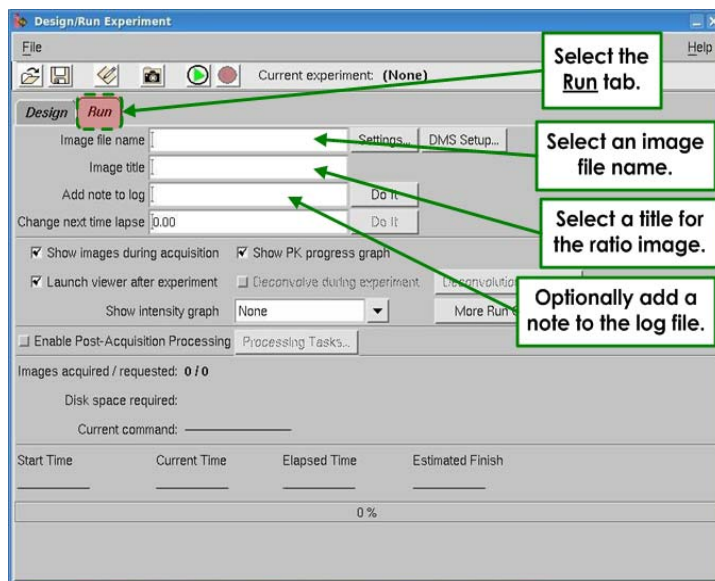

8. Click the **Start Scan** button to begin the imaging process. The ratio imaging process will occur in a separate Image viewer similar to the following:

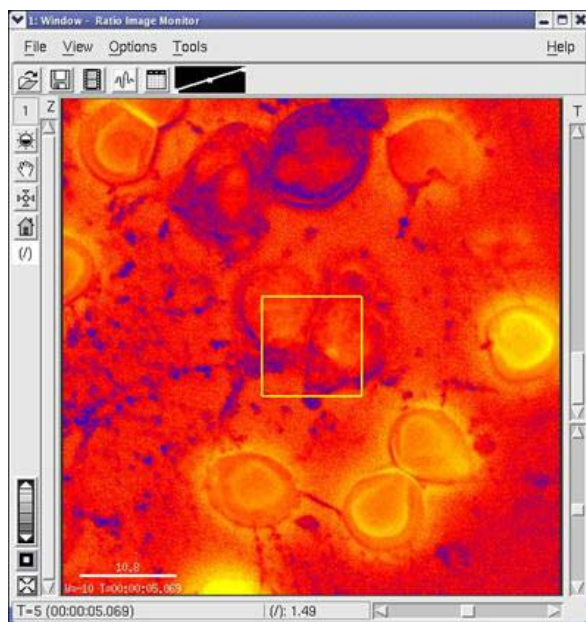

The square outline in the center of the image represents the mean value of the image data.

When the ratio imaging experiment is complete, a two-channel time-lapse image is displayed along with a ratio graph showing the mean value (the outlined area in the middle of the image) vs. time. The square outline represents the portion of the image used to calculate the mean for a ratio graph.

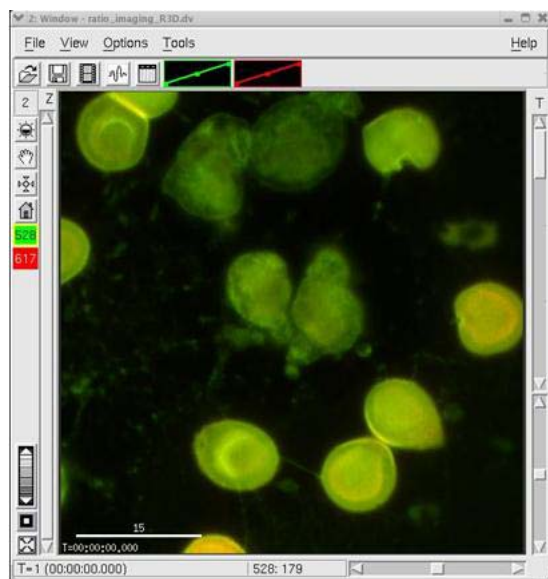

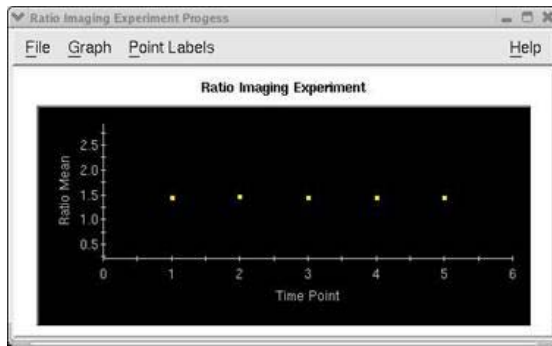

## Using the Microtiter Stage Option

The addition of a Microtiter stage to a *DeltaVision* system enhances the imaging system's capability by providing the ability to scan microtiter plates. With a Microtiter stage on a *DeltaVision* system, you can design a plate scan by generating a point list that corresponds to the nominal center point of each well of interest, and then defining how the wells are to be sampled.

The model used for sampling plates is a matrix of N rows by M columns of *panels* for each well. Each panel can be a Z stack, a single Z, or an *OAI* (optical axis integration) scan.



**Note** These panels are never stitched together like the panels defined in the Panels tab of the Experiment window.

The panels can be separated by spacing defined through the software. You can specify autofocus for each individual well, or for every panel within the matrix. You can also set up parameters to specify the autofocus sampling range that represents the well-to-well and panel-to-panel variability of the focal plane.



**Note** Although it's possible to use Z stacks with panels, it is not recommended. The data sets can get extremely large very quickly.

---



Microtiter Stage for *DeltaVision* Systems

## Before Operating the Microtiter Stage

The Microtiter stage requires 3 hours of warm-up time before the stage has stabilized. This warm-up time is necessary even if you are using an environmental chamber.

- The motors need ample warm-up time due to the long lead screws.
- Significant X, Y, and Z drift has been observed prior to 3 hours of warm-up. To avoid this drift, a complete system warm-up is essential.
- You can help the system warm up faster by running a continuous time-lapse experiment with 6 points covering the span of a 96-well plate.
- Aurora and MatriCal Microtiter plates are recommended for use with the Microtiter stage.
- Cell culture plates are not of optical quality and therefore will not work with the Microtiter stage.
- If you are using the plate-scanning feature, an air objective is recommended. It is difficult to be successful scanning large areas of a plate using an oil objective.
- It is imperative for proper scanning autofocus that all of the objectives have the correct lens information attached to them in the `Resolve3D.SYS` file. If you click on the **Info** button next to the **Lens** drop-down list, all of the fields for the objective should be filled.



**WARNING!** Do not remove any guarding or protective components from the Microtiter stage.

---

## Loading a Microtiter Plate

To load a microtiter plate:

1. From the Resolve3D main menu, select the **Microtiter Plate**  icon.

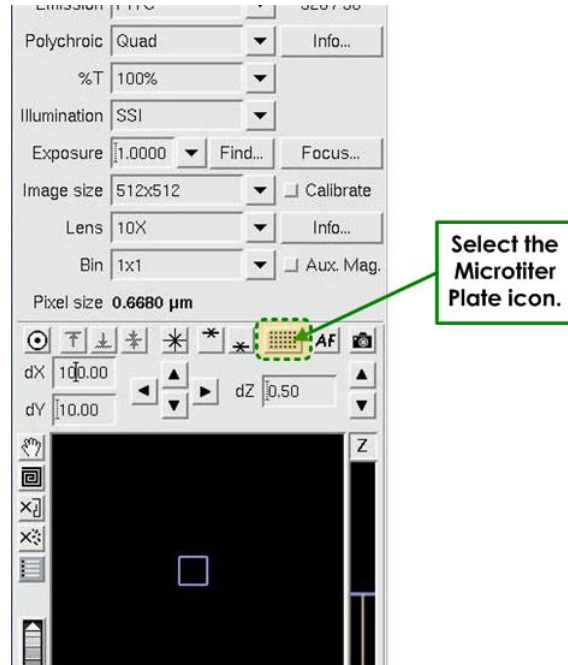

### Resolve3D | Microtiter Plate Icon

A representation of the microtiter plate is displayed in the Plate View window. The following illustration provides an overview of the functions available from the Plate View window.

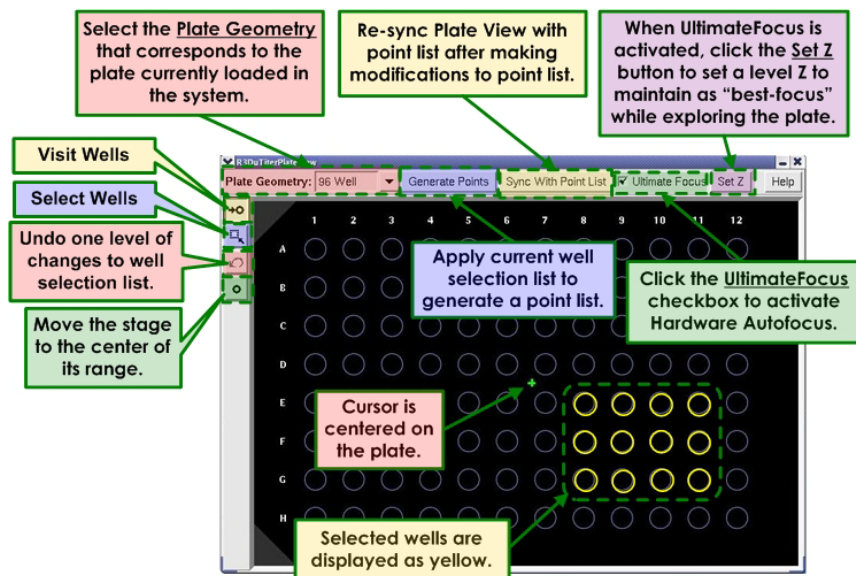

### Plate View Overview

The Plate View window initially opens with the interaction mode set to **Visit Wells** as shown.



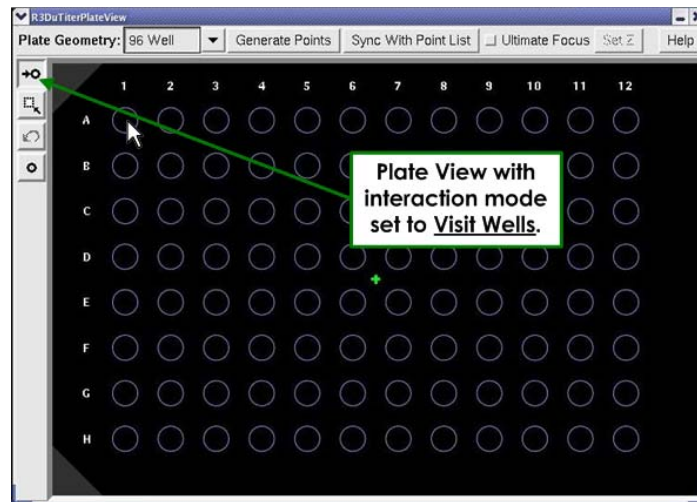

2. Load a plate into the plate carrier as shown:
  - a. Insert the right edge of the selected plate onto the right edge of the plate carrier.



- b. Depress the spring-loaded stabilizer in the top-left corner of the plate carrier.

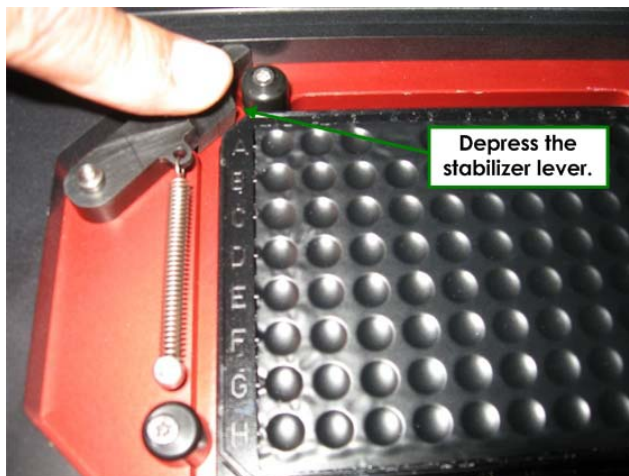

- c. Release the stabilizer so that it rests against the corner of the plate.

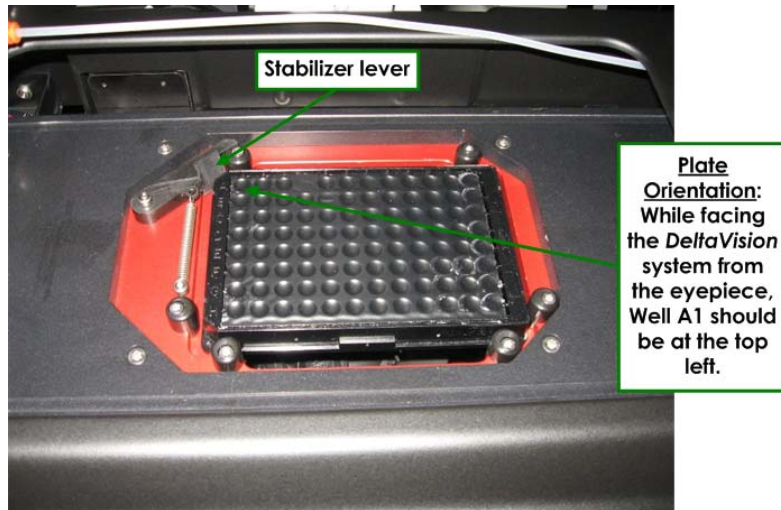

3. When loaded properly, the microtiter plate should be level in the plate carrier.

## Exploring a Microtiter Plate

To explore a microtiter plate:

1. From the Resolve3D main menu, select the **Microtiter Plate**  icon. A representation of the microtiter plate is displayed in the Plate View window.

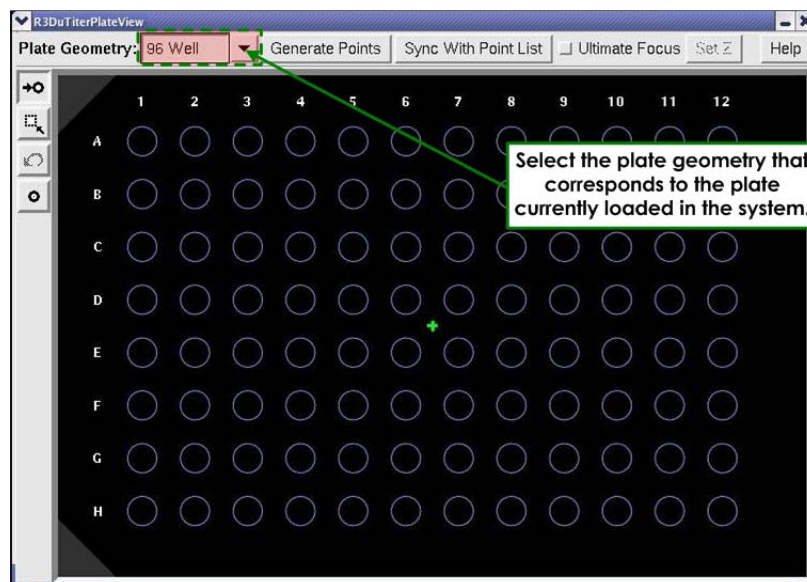



Plate Geometry Overlay

2. From the **Plate Geometry Overlay** field, select the plate geometry that corresponds to the plate you have loaded into the system for this experiment.

3. Click the **Visit**  icon to put the Plate View window in Visit mode.
4. Click on a well to visit the nominal X/Y center of the well.
5. Through the oculars, perform a rough focus on the first well of the plate using the microscope's focus knobs.



**Note** After obtaining a rough focus on the first well, you should not need to use the focus knobs.

6. Click the **Autofocus**  icon from the Resolve3D window to activate Autofocus. If the UltimateFocus Module is installed on your system, you can also set up the UltimateFocus feature to help maintain the plate focus. See *Using UltimateFocus* on Page 7.39 for more information.



**Note** If you're still having trouble focusing, you may need to adjust the setting in the **Maximum Z test range (µm)** field (Settings window | **Autofocus** tab).

7. Explore the plate to set up filters, exposure times, binning, and the rest of the variables you would normally configure for an acquisition.

## Designing a Plate Scan Experiment

To design an acquisition for a microtiter plate:



**Note** Before you begin designing a plate acquisition, be sure to wait until the system has completely stabilized.

1. From the Resolve3D window, click the **Experiment** icon to display the Design/Run Experiment window.
2. Click the **Design** tab.

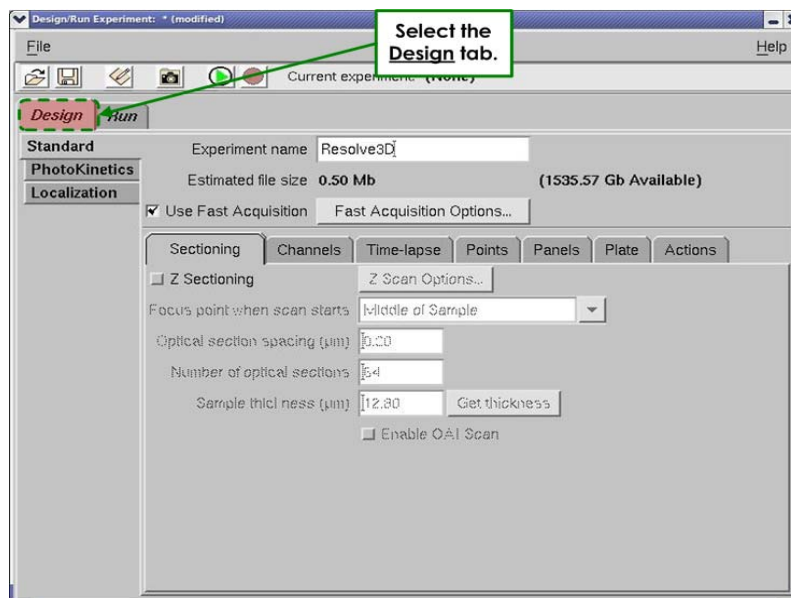

- Set up Z sectioning and channels as usual. The experiment design elements of **Time Lapse**, **Points**, **Panels**, and **Actions** are incompatible with Plate Scanning. These features are not used in this process.
- Select the **Plate** tab and activate the **Do Microtiter Plate Scanning** check box.

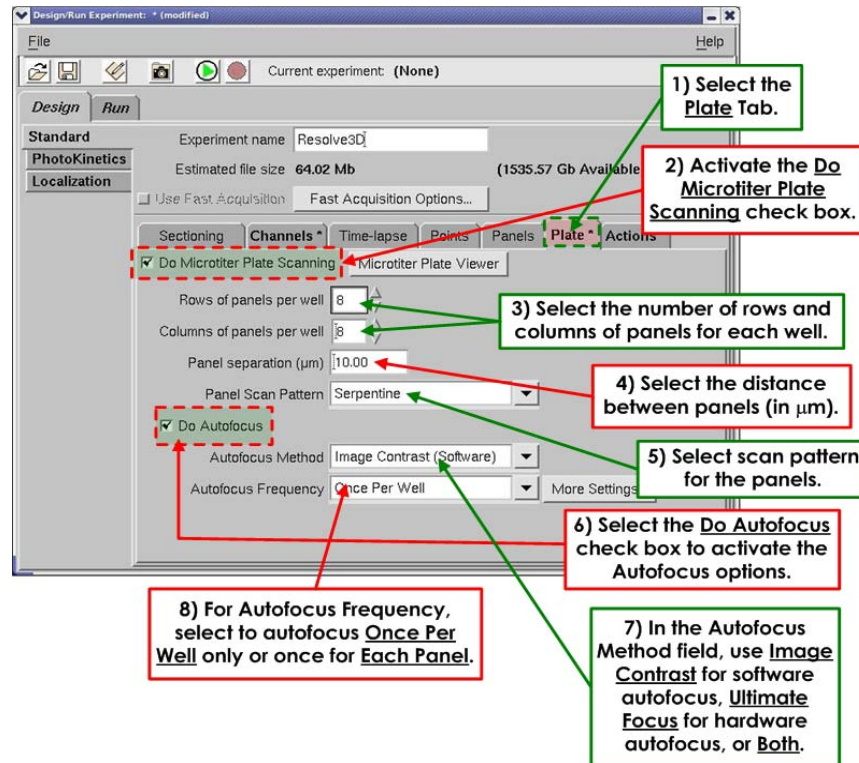

- In the **Rows of panels per well** and **Columns of panels per well** fields, specify the number of rows and columns of panels to be used to sample each well's contents. Keep in mind that using large numbers of panels can generate huge amounts of data.



**Note** Panels are saved as time points within one image.

6. In the **Panel Scan Pattern** field, select **Serpentine** or **Raster**. The **Serpentine** panel scan pattern is bi-directional.

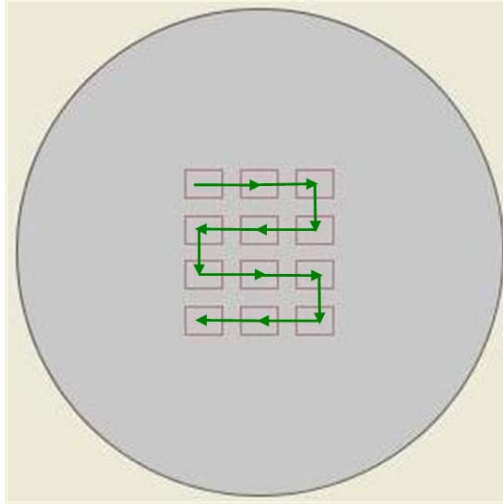

**Serpentine Panel Scan Pattern**

7. The Raster panel scan pattern is unidirectional.

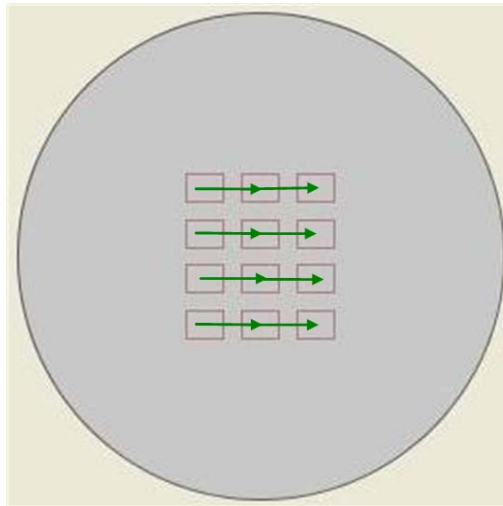

**Raster Panel Scan Pattern**

8. The length of time it takes to perform a Serpentine scan is less than the length of time for performing a Raster scan. This is because, with a raster scan, the microtiter stage must return to the beginning of each row of panels to start the next row. However, due to the unavoidable hysteresis involved with the bi-directional Serpentine scan, a Raster scan will always be the more accurate.



**Note** *Hysteresis* refers to the position differential of the stage when approaching a specific location from different directions due to mechanical conditions. In this case, the change in the direction of the scan results in a very slight, but nevertheless measurable, position difference between similar locations visited from the opposite direction.

9. On the positive side, using a Serpentine scan pattern can actually increase the reliability of panel-to-panel autofocus.



**Note** It is recommended that the Serpentine scan pattern is used whenever the experiment is relying on autofocus to scan.

10. In the **Panel Separation** field, specify the distance (in  $\mu\text{m}$ ) for panel separation. The single value is used for both horizontal and vertical separation of panels. The following graphic uses 300  $\mu\text{m}$  as an example.

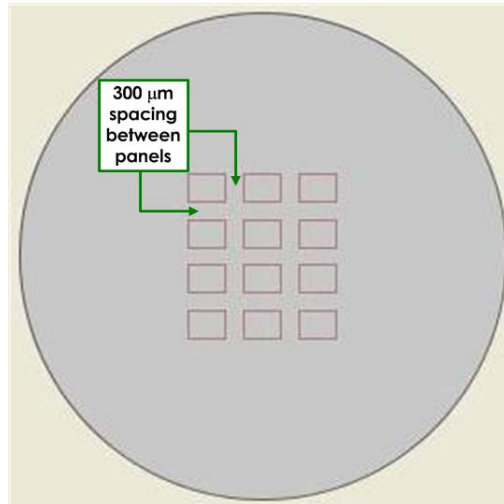

**Panel Separation**

11. Select the **Do Autofocus** check box to activate the autofocus fields.
12. In the **Autofocus Method** field, choose an appropriate Autofocus model to use for this acquisition. The options for this field are as follows:
- **UltimateFocus (Hardware)** – This method uses a laser (hardware) to perform autofocus on the sample.
  - **Image Contrast (Software)** – This method uses the software autofocus feature to perform autofocus on the sample.
  - **Both** – The UltimateFocus and then Image Contrast methods are used.

If you would like to modify the Image Contrast search parameters, click **Settings** on the Resolve3D control panel and see the **Autofocus** tab for Plate Scan parameters. The “long” range is used when doing the **Once Per Well** model or on the first panel of an **Each Panel** Autofocus style. The “short” range is used when focusing on each panel within a well. These values are retained, but are not part of the experiment macro.

13. In the **Autofocus Frequency** field, select how often you want the autofocus process to occur for this acquisition. The options for this field are as follows:
- **Once Per Well** – the stage moves to the center of the well, Autofocus finds the best plane of focus, and then the stage moves back to the first panel of the well.
  - **Each Panel** – Autofocus is used on every panel in every selected well.

For the default panel separation of 10  $\mu\text{m}$ , you may not need to use autofocus on every panel. When autofocus is used on every panel, you run a greater risk of photo-bleaching the sample. Check to be sure you need to autofocus every panel by scanning only the first well in your experiment.

- To adjust the Autofocus parameters, click the **More Settings** button next to the **Autofocus Frequency** field.

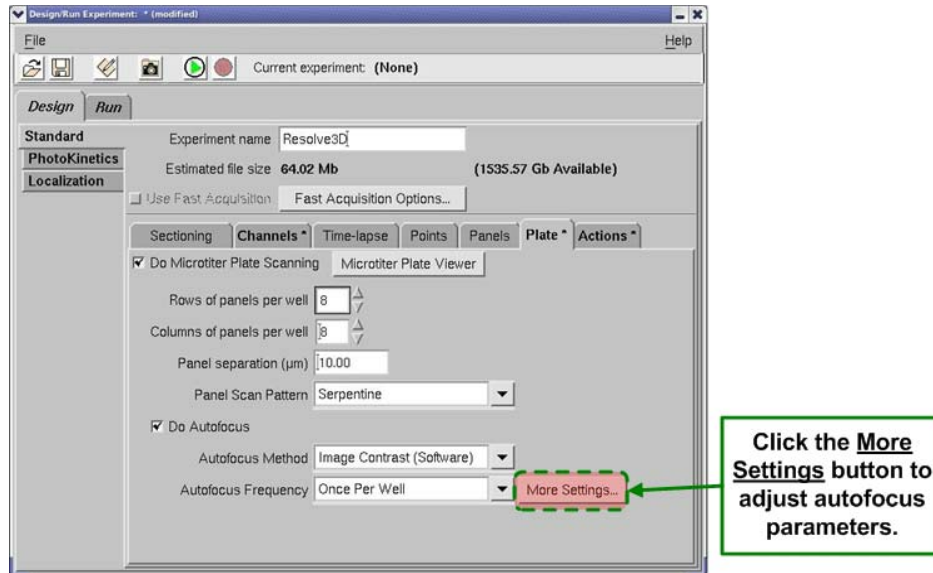

- The Plate Autofocus Settings window is displayed.

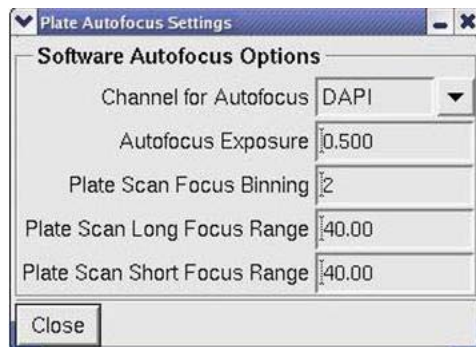

The fields in the Plate Autofocus Settings window are used as follows:

- Channel for Autofocus:** Select the desired channel for autofocus. You are selecting the EX Filter. The parameters for EM and ND are taken from the last image acquired with that EX filter in the Resolve3D window.
- Autofocus Exposure:** Set the autofocus exposure time. You will want to use the same or a shorter exposure time than what will be used during the acquisition time in your experiment. In order to make sure that your Autofocus

Exposure time is not longer than necessary, test the exposure time using the same binning value in the Resolve3D Window.



**Note** You may have to adjust the Resolve3D Autofocus settings in order to find the best focal plane using the **Autofocus** icon. Remember that the Plate Autofocus Settings are not the same as the Resolve3D Autofocus settings.

---

- **Plate Scan Focus Binning:** The default is set to a bin of 2x2. It is recommended to use binning for the autofocus for most samples in order to reduce the amount of light exposure to the cells. Please enter a single digit for this value. A Plate Scan Focus Binning of 2 is similar to a 2x2 in the Resolve3D window.



**Note** The software is set up so that you can autofocus with a different bin than acquisition. For example, you can autofocus with a binning of 2x2 and acquire data with a binning of 1x1.

---

- **Plate Scan Long Focus Range:** This value is the Maximum Z Test Range for the first image in every well. If autofocusing **Once Per Well**, this is the only Focus Range that is used for the experiment. If autofocusing **Each Panel**, this Focus Range is used only on the first panel in each well.
  - The **Plate Scan Long Focus Range** is combined with the Lens' Depth of Focus in order to find the best focal plane during the scan. It is imperative that the correct lens has been selected in the Resolve3D window and that the Lens has a valid Lens ID.
  - You cannot change the Z Step Size for the **Plate Scan Long Focus Range**. The system will take the same sized steps no matter the value of the **Plate Scan Long Focus Range**. Therefore, a scan of 100 microns will take twice the amount of time when compared to a scan of 50 microns.
  - When you are imaging multiple wells, the Plate Scan Autofocus starts from the best plane of focus from the previously scanned well. It then searches for the best signal-to-noise ratio in the distance  $\frac{1}{2}$  of the value of the **Plate Scan Long Focus Range** above that focal plane and  $\frac{1}{2}$  of the value of the **Plate Scan Long Focus Range** below that focal plane.

#### To determine an estimate for the Long Focus Range:

In order to determine a good estimate for the **Plate Scan Long Focus Range** value, you will need to manually determine the distance between focal planes in the four corners of your plate (or the 4 corners of the wells filled within your plate).

- Wells A1 and A2:
  - Use the Resolve3D Window to find the best focal plane in A1.  
**Note:** The microscope's focus knobs should *not* be used at this point.
  - Write down the Z coordinate from the Resolve3D Window (location highlighted in the yellow box to the left).
  - Move to A2. Use the Resolve3D Window to find the best focal plane.
  - Subtract:  $Z_{(\text{focal plane A2})} - Z_{(\text{focal plane A1})}$
  - Record the difference.



- Repeat for Wells A11 and A12.
  - Don't be concerned about the focal plane difference from A2 to A11. The focal plane will adjust as you move along Row A.
- Repeat for Wells H11 and H12.
- Repeat for Wells H1 and H2.
- Find the largest distance between wells from the tests above. Double this value and enter it as the estimate for the **Plate Scan Long Focus Range**. Make sure that this value is within the working distance of the objective.
- **Plate Scan Short Focus Range:** This is the Maximum Z Test Range between panels in a plate scan. If imaging more than one panel in each well, this value will be used for each panel after the first one.
  - The **Plate Scan Short Focus Range** is combined with the Lens' Depth of Focus in order to find the best focal plane within panels during the scan. It is imperative that the correct lens has been selected in the Resolve3D window and that the lens has a valid Lens ID.
  - You cannot change the Z Step Test Size for the **Plate Scan Short Focus Range**, which is the same as with the **Plate Scan Long Focus Range**.
  - To determine if autofocusing within wells is necessary or to determine the value for the **Plate Scan Short Focus Range**, measure the change in Z throughout one well. Find the best focal planes in different fields of view within close proximity in a well and use the Z coordinates to find out the distance between focal planes. Double the largest difference in Z to get the **Plate Scan Short Focus Range**.



**Note** If the distance between Z planes is not significant, you may want to consider autofocusing **Once Per Well** only. Running the autofocus once per well instead of per panel will save time for your experiment and will save your sample from the effects of photobleaching and/or phototoxicity.

---

16. Use the Plate View window to make a selection of wells to scan. From the Plate View window, click the  icon to change to **Select** mode.
17. With the mouse, click and drag an outlined region to select a group of wells on the plate. Click and drag while holding the Shift key down to extend the selection or to de-

select specific wells. You can use the **Undo**  icon to undo one level of changes to the well selection list.

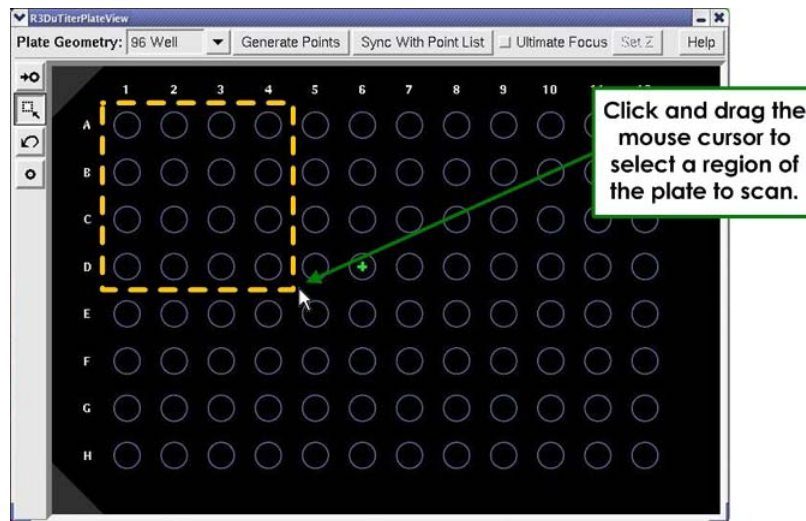

**Plate Region Selection**

18. The selected wells are highlighted in the Plate View window.

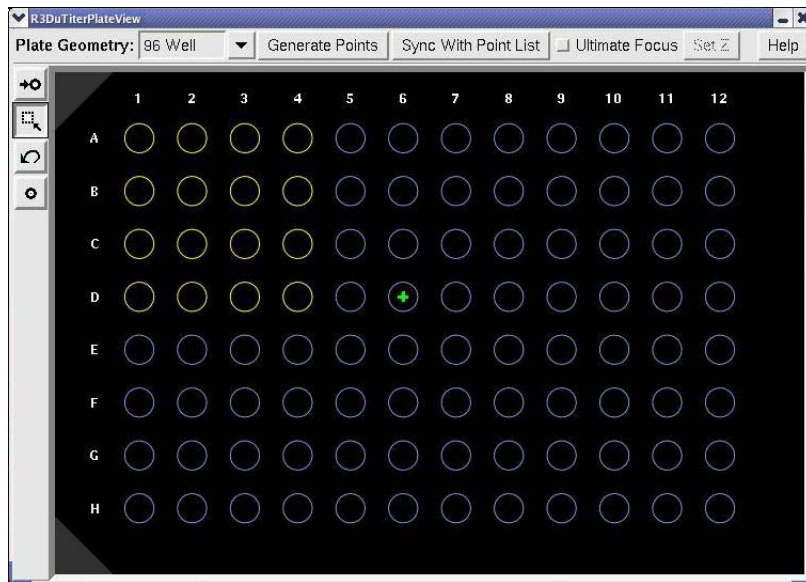

**Selected wells are highlighted.**

Alternatively, you can click on the row letters or column numbers to select the entire row or column.

Use this method in combination with the Shift key to select multiple rows or columns (or rows *and* columns).

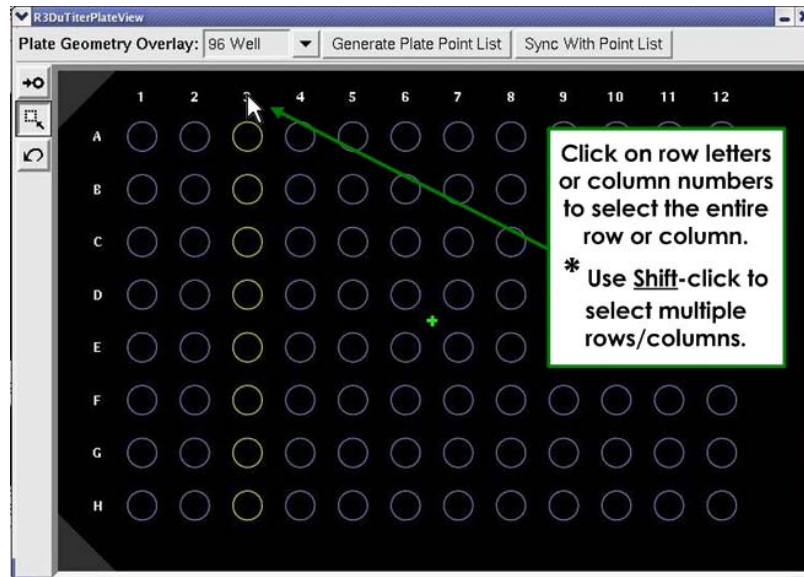

19. When you are satisfied with the well selection, click the **Visit Wells**  icon and click on the top left well in your selected list.
20. Bring this well into focus to set the best Z estimate for the start of the scan.
21. In the Plate View window, click **Generate Plate Point List** to apply your well selection list.

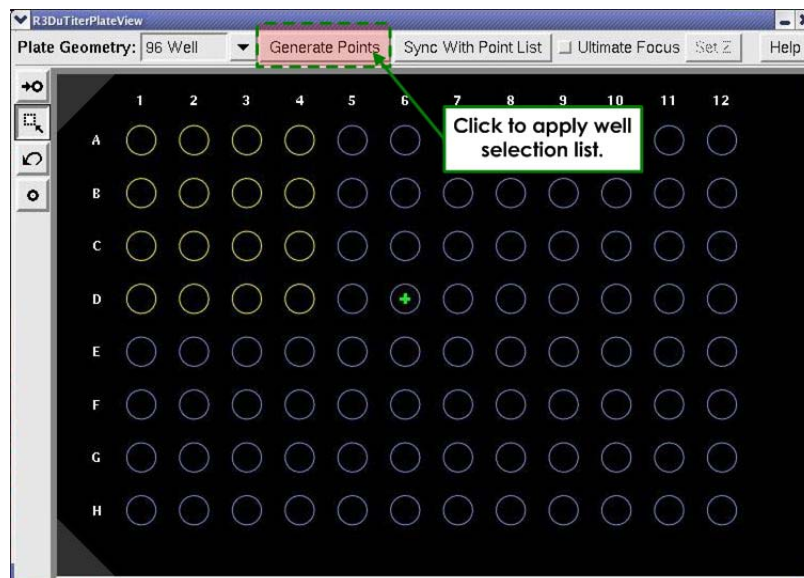

22. You can check your point list by selecting the **Marked Points List**  icon in the Resolve3D window. The Point List window is displayed.

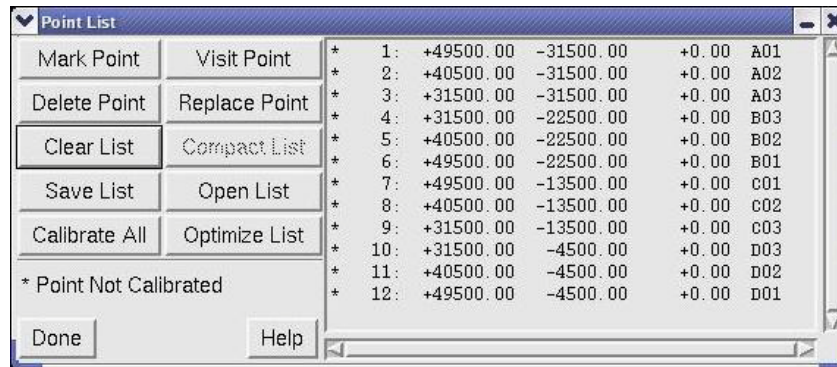

#### Point List Window

23. Notice in the Point List window that the points are labeled with the Well Row/Column specification.
24. Return to the Design/Run Experiment tool and save the experiment.

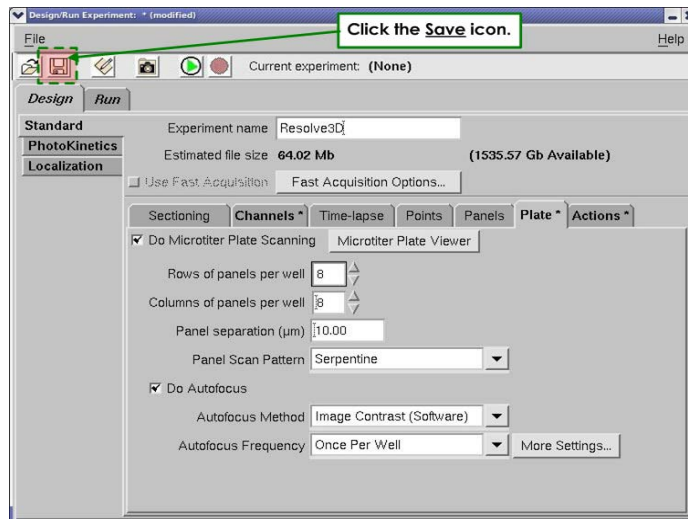

**Note** The saved Experiment Macro tells the system how you want the well scanning to be done. The Plate Point List tells the system what you want to scan. Since the Experiment Macro and the Plate Point List are relatively independent from one another, you can re-use the Experiment macro with a different list of selected wells, or you could re-use the list of selected wells and perform multiple styles of imaging on the same list.

## Running a Microtiter Plate Scan

### To run a scan:

1. For best Autofocus results, visit the first well (the upper-left corner) of your selection using the Plate Viewer. On the Marked Point list, this should be the top entry.

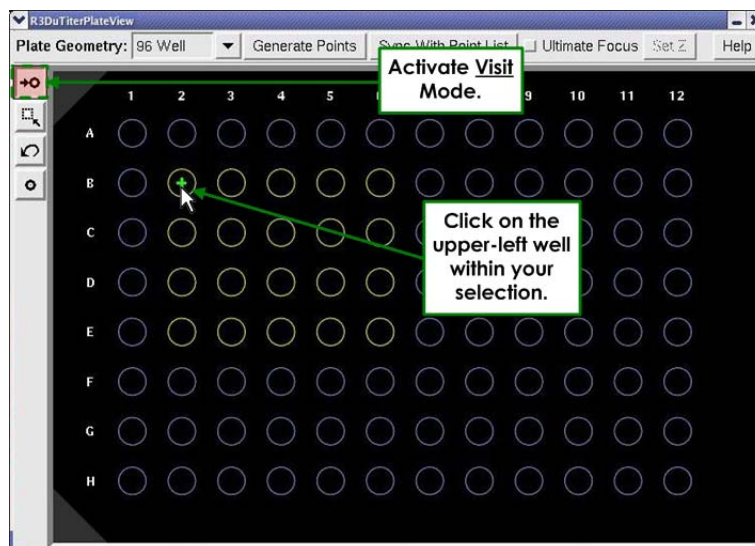

2. Use the **Autofocus** icon **AF** in the Resolve3D window to find the best focus. When you are satisfied with the focus, choose **Replace Point** from the Point List window to restate the Z position of that point.
3. In the Design/Run Experiment tool, provide a name for the experiment.

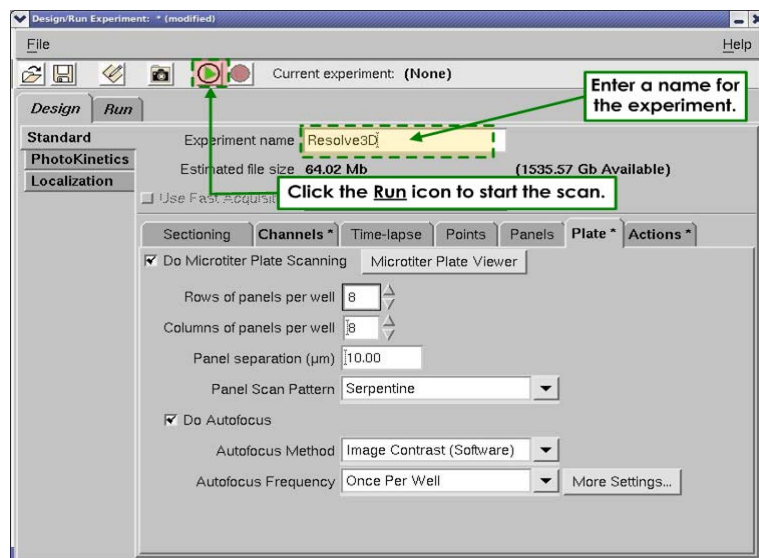

Resolve3D automatically creates a subdirectory of your current data folder with the name you provide here. All of the scan data for this experiment are placed in that folder.

- Click the **Run**  icon to start the scan.

You can stop the scan at any time using the **Stop**  icon. When you abort the scan in this manner, scan data is lost for all unfinished wells.

The most effective way of monitoring the scan is using the Plate Viewer. It updates its current location indicator whenever it moves in X and Y.

## Reviewing a Finished Plate Scan

### To review a finished scan:

- From the *softWoRx* main menu bar, select **Utilities | Review Plate Scan**. The Plate Scan Reviewer window is displayed.

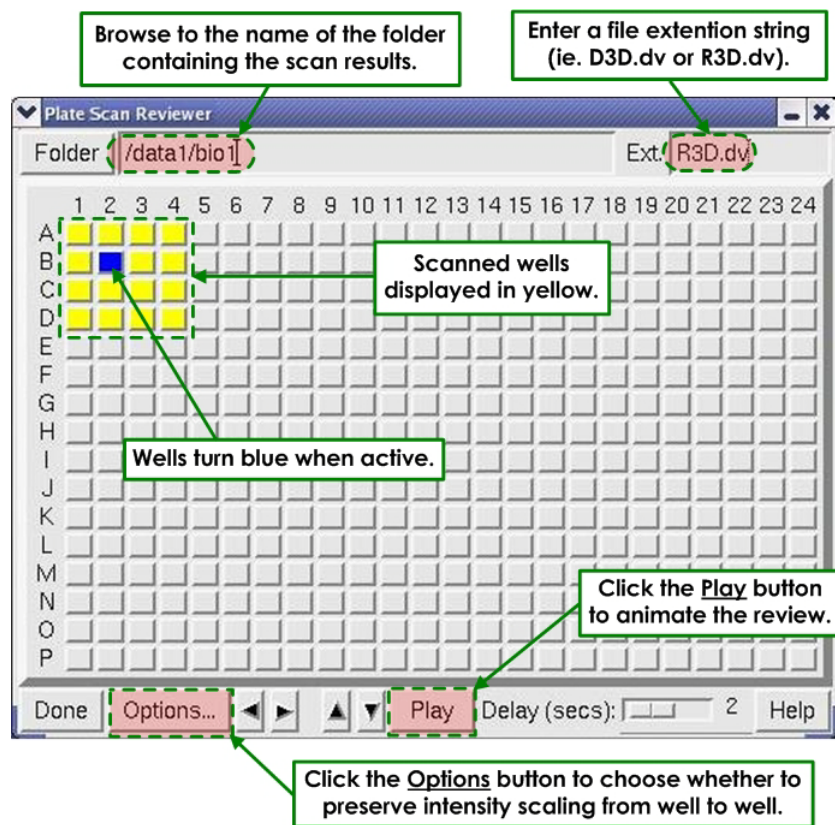

- Click the **Folder** button to select the folder where you saved the scan.
- If the data is already processed, you may need to specify the file extension string (like D3D.dv or R3D.dv) to view the files of interest. If files are found that adhere to the plate scan file naming convention, they are displayed as yellow buttons on the Plate Scan Reviewer tool. Click on a yellow button to open the Image Viewer and display an image from that well. The button turns blue when active.

4. Select the **Play** button to animate the review. The Play mode steps through all of the images in order.



**Hint:** Use the Image Window's Montage View to view all of the panels within a well. If, for instance, you scanned 2x2 panels, choose **View | Montage | 2x2** to see all the regions. This is a "Montage by Time" situation since the panels are considered the Time dimension of the *DeltaVision* file.

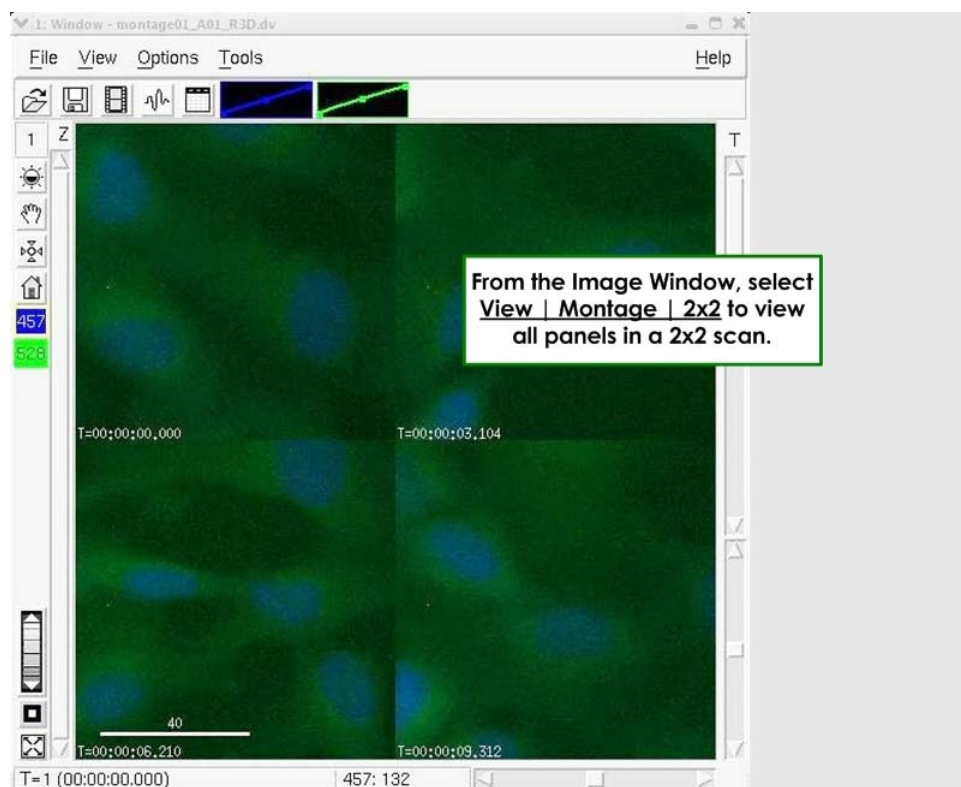

## Re-scanning Selected Wells

If you determine that you want to re-scan some of the wells (due to Autofocus miscalculations, etc.), you can re-scan an individual well or group of wells using the same objective and experiment macro. The difference is that you'll be modifying the Plate Point List to select only the well(s) to be re-scanned.



**Note** For instructions on re-scanning selected wells using a *different* objective, refer to the next section (below).

### To re-scan selected wells:

1. From the Plate View window, select the well or wells to be re-scanned and click **Generate Plate Point List** to replace the current Marked Point list with this modified one. Remember, that the points are generated with the current stage Z value, so make sure the *DeltaVision* system is in focus.

- In the Design/Run Experiment window, use the same experiment name as you used the first time. You may be prompted to re-save the experiment since the point list has changed.
- From the Design/Run Experiment window, click the **Run**  icon to restart the scan. You are prompted to confirm that you want to overwrite the file(s) you scanned before.

## Re-scanning Selected Panels with a Different Objective

If you determine that you want to re-scan some panels with a different objective (i.e. you scanned the plate with an air objective, but you'd like to reimage with a 60x oil objective) you will need to edit the coordinates of a points list in order to return to the panel location. Since the field of view is different for each objective magnification, you cannot simply rescan the panels. The method below describes the process of going back to the center coordinates of your image. If the object of interest isn't in the center of the field of view, you may have to make small movements to search for it. The region of interest will be within the field of view of the oculars, so it may also be helpful to switch to the oculars to locate it.

### To re-scan selected panels with a different objective:

Find the coordinates for your panel of interest as follows:

- In the Resolve3D log file (\*R3D.dv.log), find the image of interest. It will be displayed as a time point. Write down the time point number.
- To find the image number, multiply the time point number by the number of wavelengths acquired in the experiment (for example, if the time point is 25 and you have DAPI and FITC in your channel, the image number is 50).

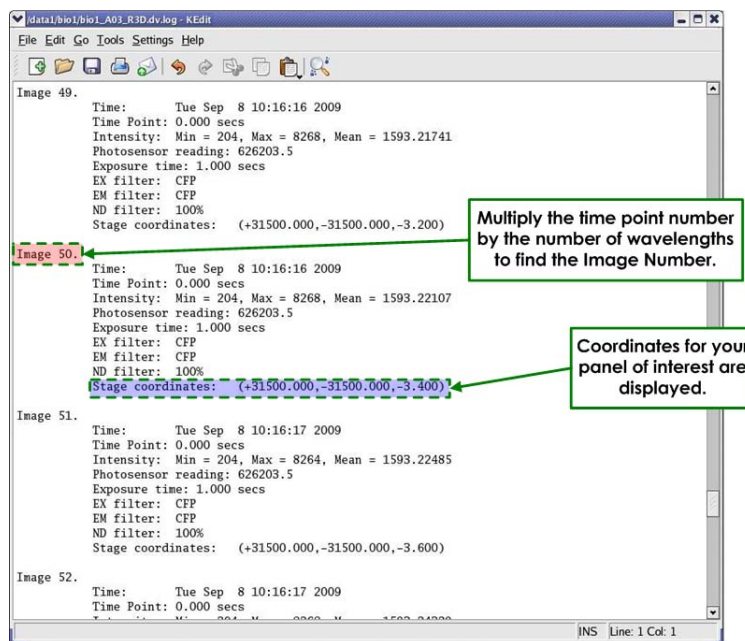



- Every acquisition experiment creates a log file (image\_name.dv.log). Open the log file for your image.
- Find the image number calculated in Step 1 and write down the X, Y, and Z coordinates for all of the points that you would like to revisit.



**Note** It's critically important that you include both positive (+) and negative (-) indicators when noting coordinates.

#### Edit the Point List as follows:

- From the Resolve3D window, click on the **Marked Points List**  icon. The Point List window is displayed.
- Press the **Clear List** button.
- Use the Joystick to navigate to a location in X, Y to revisit with the new objective.
- Find the best plane of focus.



**Note** Upon returning to a previously visited point, you may need to search around to find the exact location. Also you will always need to adjust the Z focus. This is especially true when you change objectives.

- Press the **Mark Point** button.
- Repeat Steps 3 through 5 for as many points as you want to revisit.

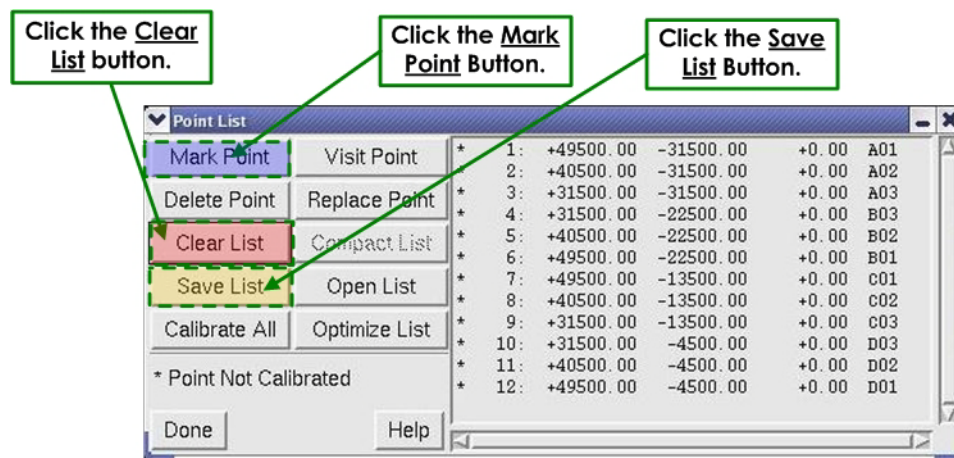

- Click on the **Save List** button. The Save Point List File window is displayed.

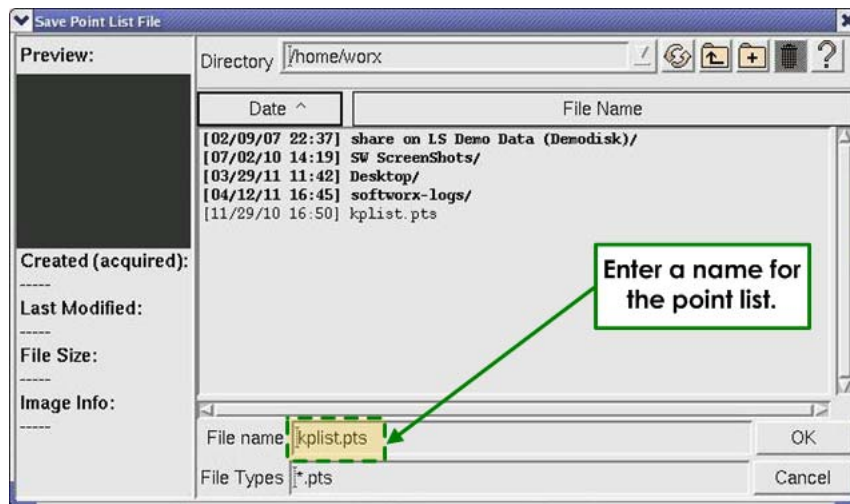

8. Give the Point List a Name and click **OK**.

## Adding Overlays to the Microtiter Overlay Window

Your system was set up with the overlay options of the 96-well and 384-well plates. The instructions in this section describe the method for adding 2, 4, 6, 12, 24, and 48-well plates to the Microtiter Overlay window.

### To add plate overlays to the Overlay window:

1. Open the `scan_overlay_standard.db.txt` file from the `/usr/local/softWoRx/config` folder.
2. Locate the desired plate configuration in the **Name** field.
3. Record the **Type Number** corresponding to the plate configuration. For example, if you were to add the 2-well plate, you would record a type number of 2002.
4. Save a backup copy of the `scan_overlays.txt` file in the `/usr/local/softWoRx/config` folder.
5. Open the `scan_overlays.txt` file.
6. Add "Type Number = xxxx" for the overlay(s) that you would like to add, where xxxx is the **Type Number** recorded in Step 3.



**Note** Do not alter the line in the `scan_overlays.txt` file that reads **Format = 2**.

7. Add more overlays in the same manner.

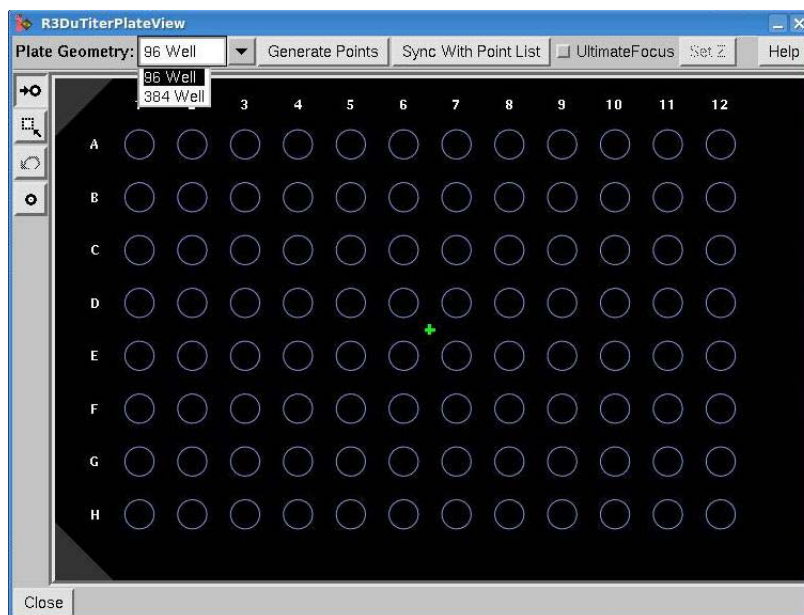
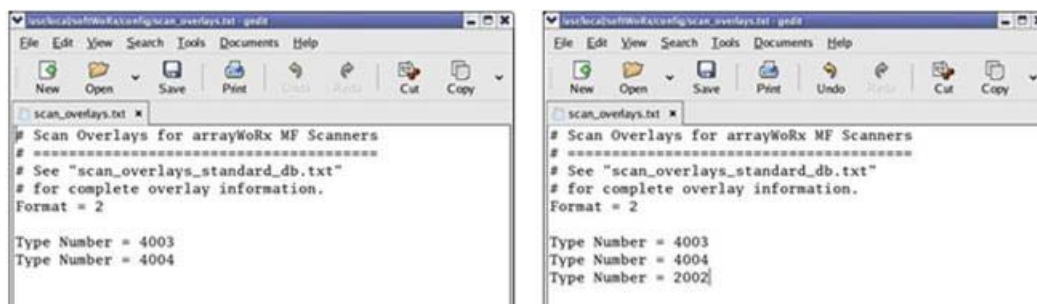

## Using UltimateFocus

If your DeltaVision system is equipped with the UltimateFocus Module, you can use this feature to help maintain focus within a specific move threshold. The UltimateFocus Module is always on and is enabled through a check box toggle available at key points from within the softWoRx software. You can use UltimateFocus either while exploring a sample, or when collecting experimental data.

After the initial plane of focus is determined, you can then scan the sample area with the UltimateFocus correction mechanism applied as follows:

1. From the Resolve3D main menu, click the **Continuous Acquire** icon. The Continuous Acquire window is displayed.

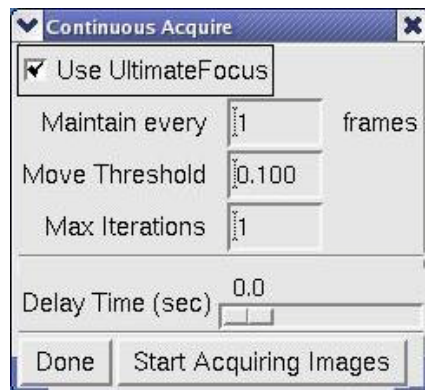

2. Activate the **Use UltimateFocus** check box.

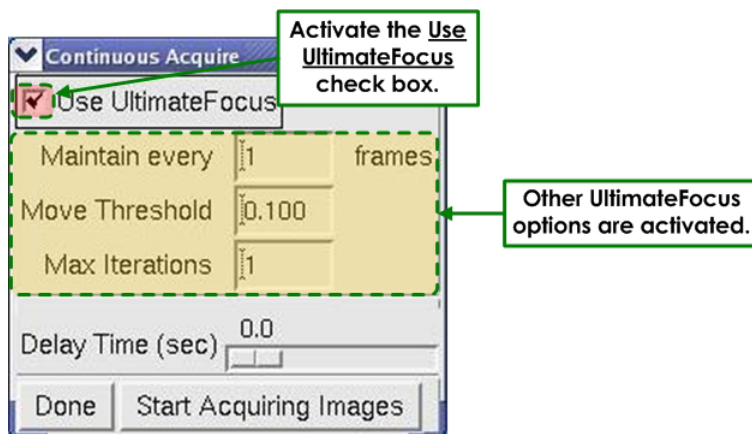

### Using the Microscope's Oculars:

The default parameters for the Continuous Acquire window are shown in the example above. With these settings, you can scan the sample looking through the oculars, with the joystick speed set to SLOW.

### During Camera Acquisition:

When you press the **Start Acquiring Images** button on the Continuous Acquire window, the camera collects images using the excitation and exposure settings currently selected in the Resolve3D main menu.

From the Continuous Acquire window, you can adjust the following focus parameters:

- The **Maintain every \_\_\_ frames** field defines how often the stage corrections for UltimateFocus are made. Entering **1** tells *softWoRx* to perform the Move Threshold check for every image, entering **2** indicates performing the process for every other image acquired, and so on. Entering a higher number in this field will increase the speed of your acquisitions.
- The **Move Threshold** field defines the minimum Z position change from the point of origin. If the change in the Z position is less than the value indicated in the **Move Threshold** field, the position of the stage *will not* change. If the

change in position is greater than the **Move Threshold**, the stage *will* move to correct the Z position. The default value is set to 0.100 microns.



**Note** For experiments in which fast acquisition speed is the most important factor, limiting the number of corrections will increase the speed of the image acquisition.

---

- The **Max Iterations** field defines the number of stage corrections the UltimateFocus module will make using the Move Threshold. This field sets the upper limit for corrective moves allowed to the stage position at one time. Limiting the number of iterations increases the speed of your image acquisitions at the possible cost of focus accuracy. For fast imaging, it is recommended that the setting in the **Max Iterations** field be set to no greater than **1**.

## Monitoring Stage Corrections

In the following Resolve3D main menu example, a sample was scanned using the UltimateFocus module. The Message Pane at the bottom of the menu lists each correction to the focal plane made by the module.

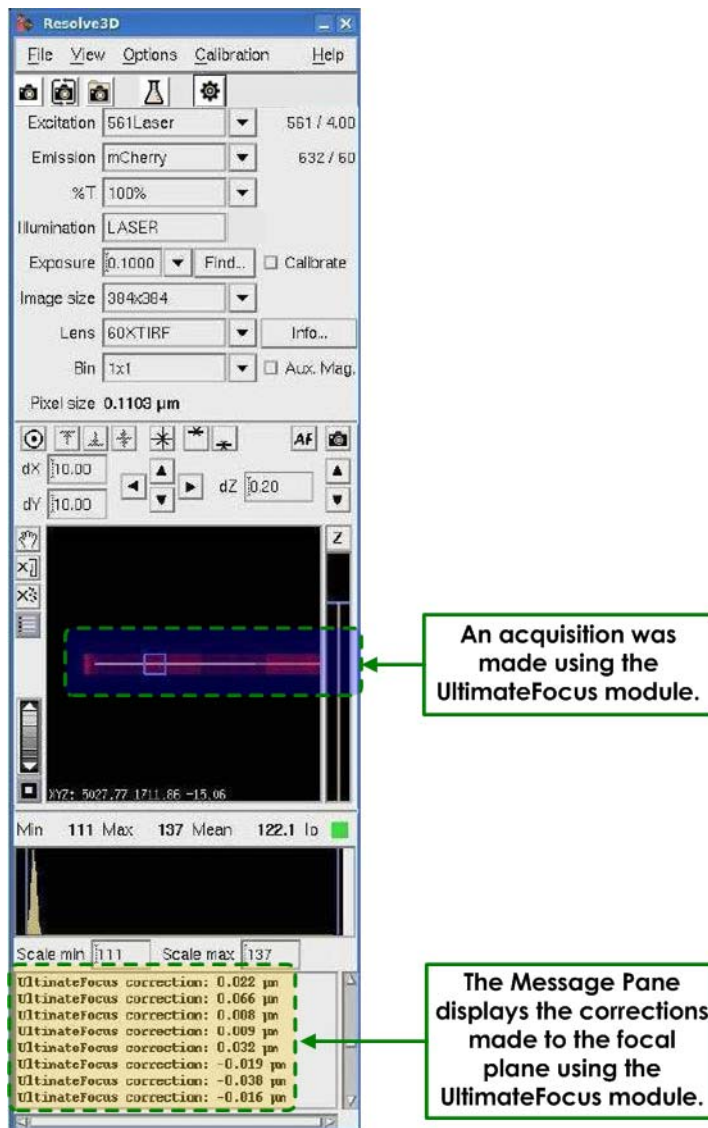

## Tips for Focus Maintenance

### Focus Maintenance with Long Time-lapse Experiments

- For time-lapse intervals much greater than the imaging time requirement.

A common problem with long time-lapse experiments has been that objects drift out of Z focus due to physical changes in the microscope stand and stage as a result of environmental conditions. To address this, softWoRx has the ability to allow periodic adjustments to be done **during** the time-lapse wait interval. To accomplish this, you can specify an UltimateFocus Action to be triggered for all time points, and further to use the **When** control to tell the system to perform the focus maintenance periodically **During** the time-lapse wait. It will be necessary to toggle the **Maintain Focus with UltimateFocus** button **Off** in the **Time-lapse** tab as the Action will be sufficient to

maintain the focus. This should provide maximum flexibility to minimize Z drift focus artifacts in the experiment.

### Focus Maintenance with Medium Time-lapse Experiments

- For short time-lapse intervals that are safely greater than the imaging time requirement.

In this scenario, you can specify **Maintain Focus with UltimateFocus** in the **Time-lapse** tab of the Experiment Designer. When you encounter this situation while running the experiment, the system will determine whether it has enough time to do the UltimateFocus maintenance and if so, do it **just before** the time lapse expires and imaging starts. The idea is to get focus adjusted as close to the start of imaging as possible.

### Focus Maintenance with Very Short Time-lapse Experiments

- For time-lapse intervals nearly the same or less than the imaging time requirement.

When imaging as fast as possible, it seems very unlikely that significant enough environmental drift would occur from one frame to the next to make a discernible difference in focus. Therefore, to maximize frame rate, you can easily design an experiment that triggers an UltimateFocus Action with a certain periodicity. For example, you can choose to do UltimateFocus maintenance **every 20** frames. You would need to toggle the **Maintain Focus with UltimateFocus** button **Off** in the **Time-lapse** tab of the Experiment Designer and add an UltimateFocus Action with **every 20** as the specification for which time points to apply the Action. This allows fairly fast imaging (as fast as conventional time lapse can do), but with an occasional UltimateFocus maintenance event to compensate for drift.

## Multi-well Plate Scanning with UltimateFocus

If your DeltaVision system is equipped with the optional Microtiter Stage and the UltimateFocus Module, the UltimateFocus can be used with the Microtiter stage to maintain focus when running a plate scanning experiment. This laser-based focus method monitors the change in the index of refraction as it goes through the coverslip and sample media. UltimateFocus will only perform well with an aqueous-based sample media.

UltimateFocus for plate scanning requires a calibration profile of the long-range focus for the plate. This profile is unique to each objective lens, polychroic, and plate type used on the DeltaVision. You'll need to perform a calibration for each objective / polychroic / plate-type combination. The profile is automatically saved for use in future experiments after you have collected the calibration. For best results, however, the calibration should be done each time the objective lens, polychroic, or plate type is changed. You'll use the sample plate to be scanned in the experiment to perform the calibration step. This will provide the best results.

### To calibrate a multi-well plate:

1. Ensure that the correct objective lens is selected in the **Lens** field of the Resolve3D main menu.
2. Select the appropriate polychroic in the **Polychroic** field.

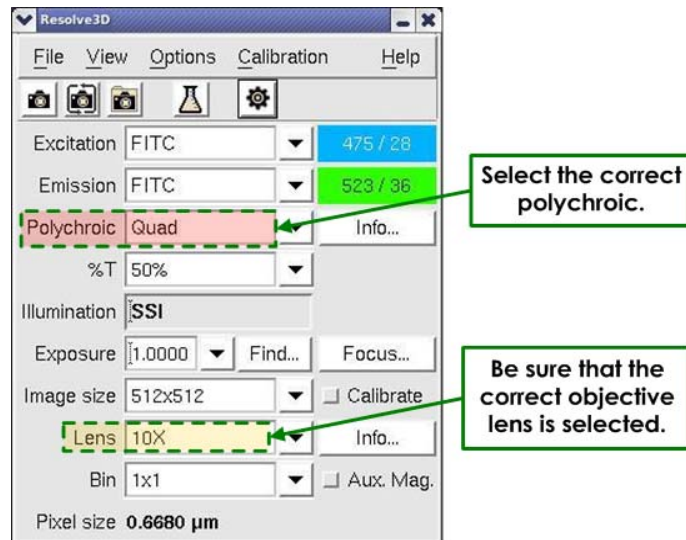

3. Click the **Settings** icon in the Resolve3D main menu to open the Settings menu. Then activate the **Autofocus** tab.

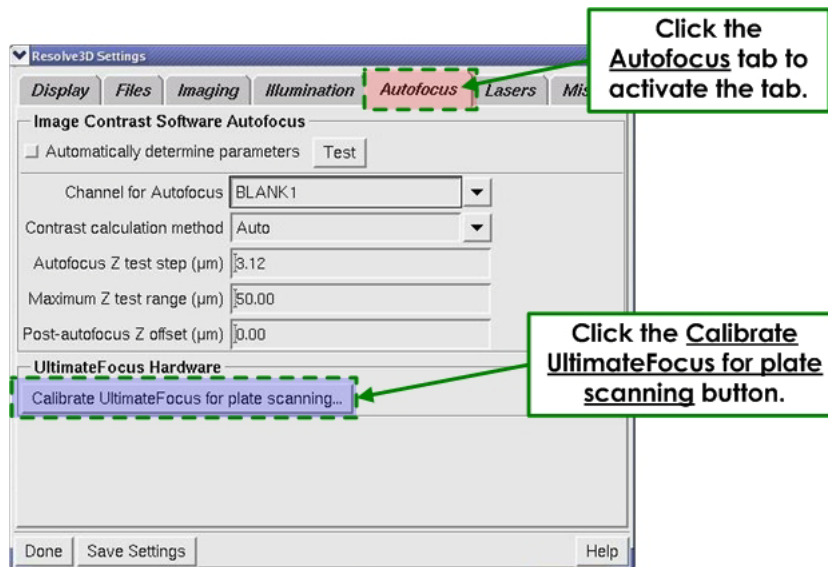

4. In the **Autofocus** tab, click the **Calibrate UltimateFocus for plate scanning** button. The UltimateFocus Plate Calibration window is displayed.



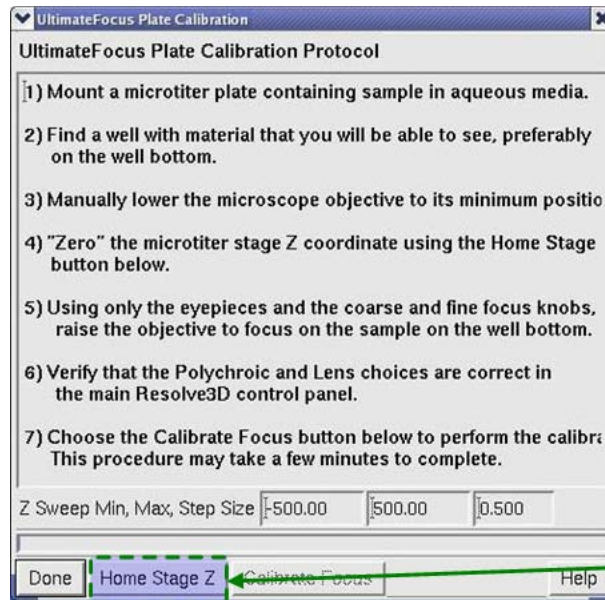

Click the **Home Stage Z** button.

5. Follow the instructions in the UltimateFocus Plate Calibration window to complete the calibration process as in the steps that follow.
6. Place a multi-well plate on the microtiter stage. (See *Loading a Microtiter Plate* on Page 7.20 for details.)
7. From the Resolve3D main menu, select the **Microtiter Plate**  icon.

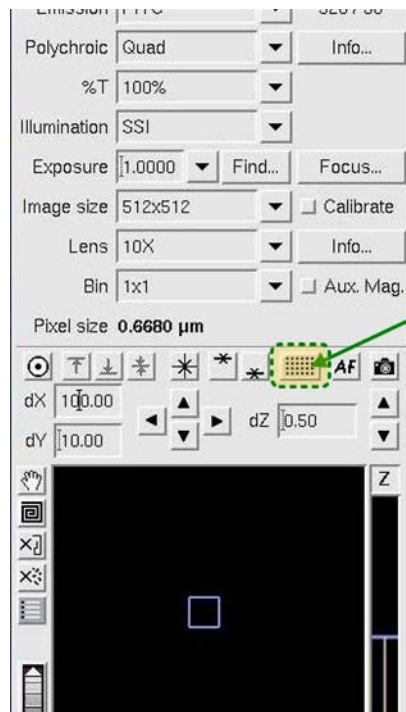

Select the **Microtiter Plate** icon.

A representation of the microtiter plate is displayed in the Plate View window.

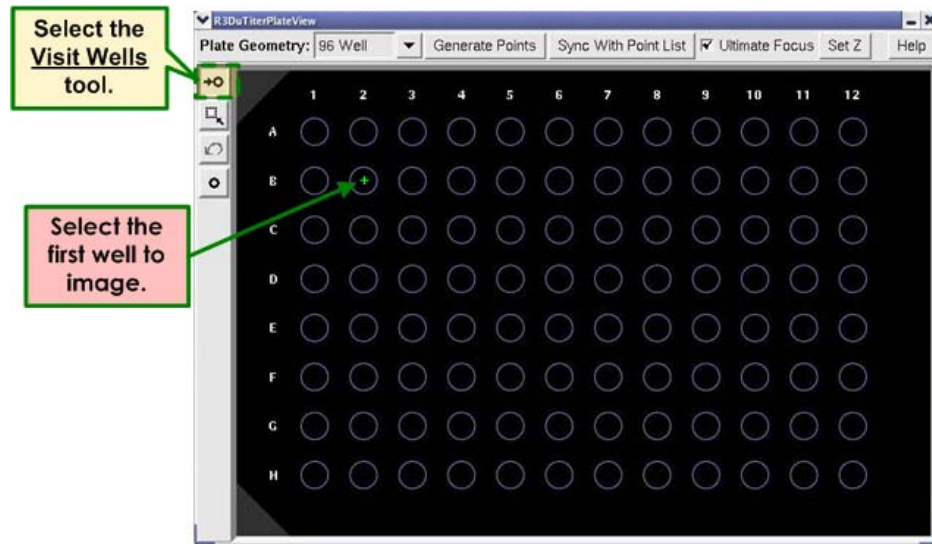

8. Select the **Visit Wells** tool and then select a well with visible sample material, preferably at the bottom of the well.
9. Manually lower the objective turret to its minimum position.
10. Click the **Home Stage Z** button at the bottom of the Ultimate Focus Plate Calibration Protocol window to “zero” the microtiter stage Z coordinate.
11. Using the eyepieces and the microscope’s manual focus controls, raise the objective to focus on the sample material at the bottom of the well.
12. Click the **Calibrate Focus** button at the bottom of the Ultimate Focus Plate Calibration Protocol window to start the calibration process.



**Note** This procedure may take a few minutes to complete.

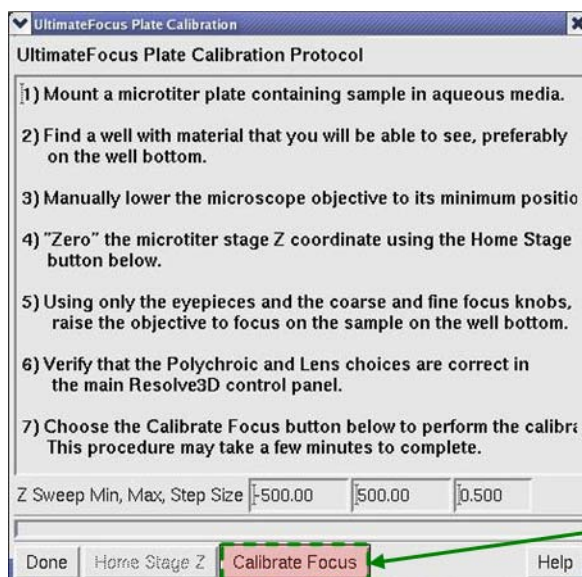

Click the **Calibrate Focus** button.

### To set up and run an UltimateFocus plate experiment:

1. Ensure that the port selector is set to the **Camera**  setting.
2. Use the controls in Resolve3D to focus on the sample and refine exposure conditions for each channel in your experiment. If your experiment will be using Z sectioning, define the desired Z thickness.
3. In the Microtiter Plate View window, use the **Select Wells** mode to highlight the wells you want to image.

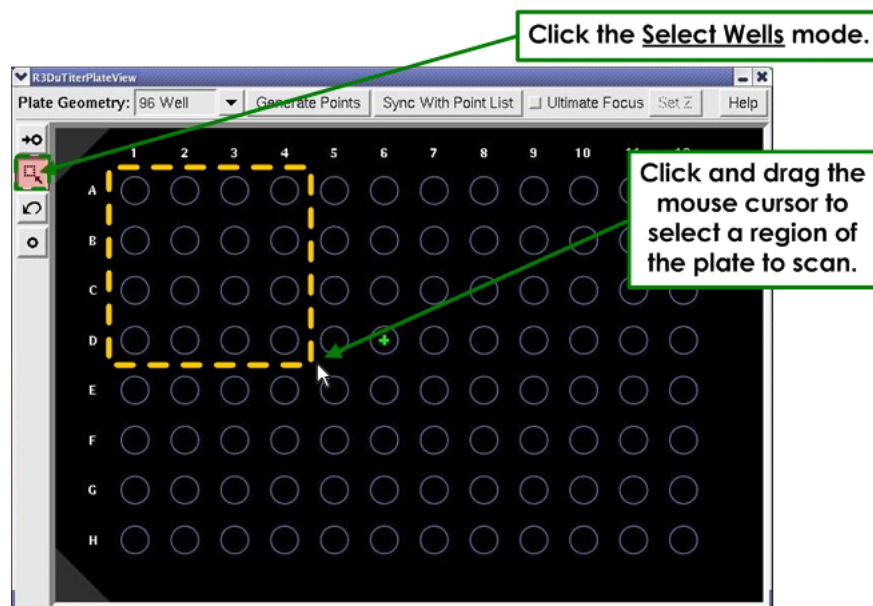

Click and drag while holding the Shift key down to extend the selection or to de-select specific wells. You can use the **Undo**  icon to undo one level of changes to the well selection list.



**Note** Alternatively, you can click on the row letters or column numbers to select the entire row or column. Use this method in combination with the Shift key to select multiple rows or columns (or rows *and* columns).

4. Click the **Generate Points** button at the top of the Plate View window.

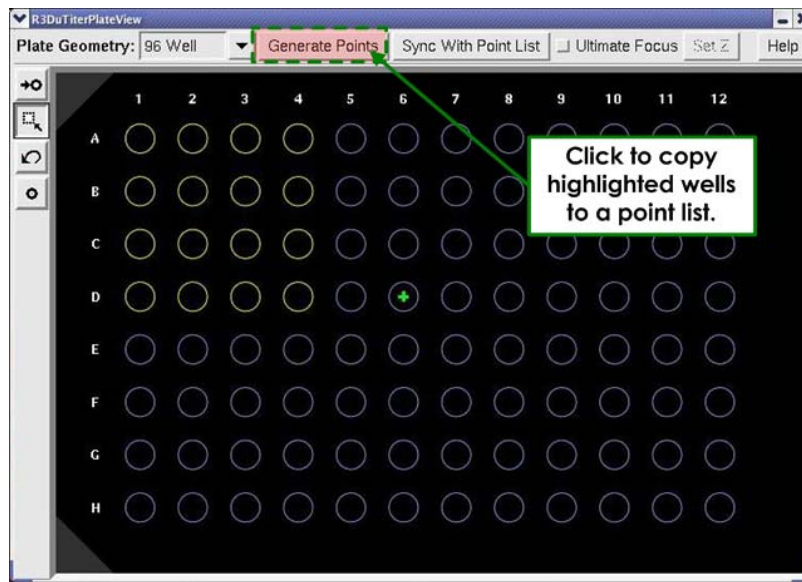

5. To use UltimateFocus to explore various wells on the plate, activate the **UltimateFocus** check box at the top of the Plate View window.
6. Click the **Set Z** button to calibrate the current focus point of the current well as the desired Z position for the experiment. **Set Z** helps the system by setting a Z offset from the interface boundary to the plane of focus which you are interested in maintaining.



7. Select the first well in the region of the plate you want to scan and click the **AF** button on the Resolve3D main menu.
8. In the Resolve3D main menu, click **Experiment** to open the Design/Run Experiment window.
9. Set up the **Sectioning**, **Channels**, and **Plate** tabs. In the **Plate** tab, select the desired autofocus method as shown.

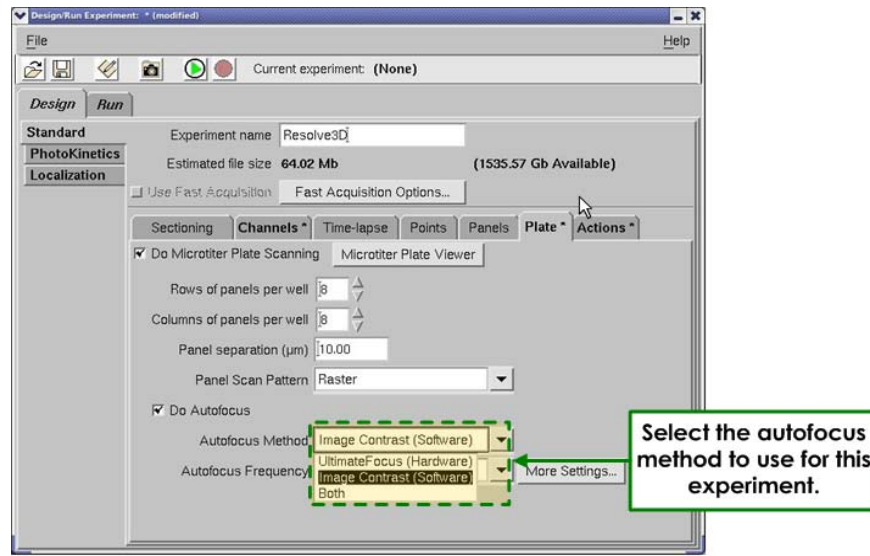

10. Click the **Run**  icon to start the scan.

You can stop the scan at any time using the **Stop**  icon. When you abort the scan in this manner, scan data is lost for all unfinished wells.



## 8. Facility Requirements/Components

---

This chapter describes the main components of the DeltaVision System. It includes the following sections:

- *Electrical and Environmental Requirements* describes the DeltaVision operating and facility requirements.
- *Overview of Components* shows the location of the key system components.
- *Optical Components* describes the system light sources, cameras, and filters.
- *Desktop Components* provides information about the monitor, the keypad and joystick, the vibration isolation table that supports the microscope, and other components.
- *Cabinet Components* describes the combined Instrument Controller and Microscope Interface Chassis (IC/MIC) and the Workstation.
- *Other Standard Components* describes the Repeatable Slide Holder, the Fiber Optic Module, the tool kit, and standard software.
- *Optional Components* describes DeltaVision options such as the X4 Laser Module, the EMCCD Camera, the Environmental Chamber, the Microtiter Stage, the InsightSSI solid state light source, the UltimateFocus<sup>®</sup> Module, Differential Interference Contrast Components, and the *softWoRx Explorer* application.
- *Consumable Parts* lists the fuses and other components that you may need to replace to maintain the system.

## Electrical and Environmental Requirements

An important aspect of collecting high quality images is meeting the proper electrical and environmental requirements for the system.

### Electrical Requirements

#### Line Requirements

**Operating Power:** Two separate circuits, both configured in one of the following ways:

- 10A Circuit: 200 - 240 VAC, 50Hz
- 15A Circuit: 100 - 120 VAC, 60Hz

Regardless of the system voltage, one circuit is used for the Instrument Controller, a heater (if the Environmental Chamber is installed), and a xenon lamp (if one is installed). The other circuit is used for the rest of the DeltaVision system.

**Transients:** Transient over-voltages in accordance with Installation Category II in IEC 664

**Maximum Power:** 1200 VA



**WARNING!** To avoid personal injury and/or damage to the system, the DeltaVision Imaging System must always be connected to a grounded power outlet.

---



**WARNING!** The DeltaVision Imaging System is intended to operate from a power source that does not apply more than 100-120/200-240V (50-60Hz) between the supply conductors or between either supply conductor and ground. A protective ground connection, by way of the grounding conductor in the power cord, is essential for safe operation.

---

#### Power Cord Set Requirements

The power cord set received with DeltaVision meets the requirements for use in the country where the equipment will be used.



**WARNING!** Only use power cords delivered or approved by GE Healthcare.

---

#### General Requirements

The requirements listed below are applicable to all countries:

- The length of the power cord set can be a maximum of 9.84 feet (3.0 m).
- All power cord sets must be approved by an acceptable accredited agency responsible for evaluation in the country where the power cord set will be used.



- The power cord set must have a minimum current capacity of 10A for 230 - 240 VAC systems or 15A for 100-120 VAC systems, as required by each country's power system.
- The appliance coupler must meet the mechanical configuration of an EN60320/IEC 320 Standard Sheet C13 (or C19 for power strip) connector.

### Country-specific Requirements

The following table shows the accredited agency and power cord set requirements for each country.

Country	Accredited Agency	Power Cord Set Requirements
Australia	EANSW	The flexible cord must be <HAR> Type HO5VV-F, 3-conductor, 1.0 mm <sup>2</sup> conductor size. Power cord set fittings (appliance coupler and wall plug) must bear the certification mark of the agency responsible for evaluation in the country where it will be used.
Austria	OVE	
Belgium	CEBC	
Denmark	DEMKO	
Finland	SETI	
France	UTE	
Germany	VDE	
Italy	IMQ	
Norway	NEMKO	
Sweden	SEMKO	
Switzerland	SEV	The flexible cord must be Type SJT or equivalent, No. 14 AWG, 3-conductor. The wall plug must be a two-pole grounding type with a NEMA 5-15P (15A, 125V) configuration.
United Kingdom	BSI	
United States	UL	The appliance coupler, flexible cord, and wall plug must bear a "T" mark and registration number in accordance with the Japanese Dentori Law. The flexible cord must be Type VCTF, 3-conductor, 2.00 mm <sup>2</sup> conductor size.
Canada	CSA	
Japan	JIS	

## Environmental Requirements

An important aspect of collecting high quality images is having the proper environment for the system. The following environmental requirements are outlined in this section.

### General Environmental Requirements

#### Floor space:

DeltaVision - 3 ft × 6 ft (90 cm × 180 cm). Include 18 in (45 cm) space behind the instrument rack.

*personalDV* - 22in x 54 to 62in (depending on whether or not the keyboard is kept in a slide-out tray). Include 18 in (45 cm) space behind instrument rack.

Maximum System Weight: 940 lbs (425 kg).

**Service:** Indoor use only.

**Temperature:** 65 - 77 °F (18 - 25 °C), daily variation of no more than 3 °F (1.8 °C). The actual room temperature should be stable to within 1 degree (Fahrenheit or Celsius) per hour.

Fluctuations in temperature will affect microscope optics, which can cause the specimen to drift approximately 1  $\mu\text{m}$  per 0.1 degree Celsius.

**Humidity:** Stable humidity levels under 50%, with daily variations of less than 10%. High humidity can result in condensation on the CCD camera window that obscures image formation. Excessive humidity may also reduce filter life and may result in chromatic aberrations in the images.

**Altitude:** up to 6550 ft (2000 m).

**Pollution:** POLLUTION DEGREE 2<sup>1</sup> in accordance with IEC 664.

Ingress Protection Level: IP20

### Communication Recommendations

Connect the workstation to a local area network for data storage and access to GE Healthcare's web site.



**CAUTION!** GE Healthcare Bio-Sciences Corporation is not responsible for damage or harm to the workstation or imaging system due to network security breaches.

---

Having a telephone in the same room as the system will facilitate communication with Technical Support if needed.

### Air Movement

Air movement around the microscope can cause specimen drift on the scale of several microns. Two common sources of air movement are window air conditioners and open windows. Central air conditioning is recommended. However, the system should not be placed in the direct path of the incoming air.

### Vibration Isolation

The vibration absorbing design of the system minimizes motion artifacts from internal vibration due to shutters, filter wheels, and stage movement. The system is also designed to damp out external vibration as well. Avoiding locations near refrigerators, elevators, ventilation equipment, and other sources of vibration will improve image resolution.

### Ambient Illumination

For best results, minimize ambient illumination during data collection. A light-tight room is recommended. Ensure that there are no light sources pointed downward into the lens.

A small desk lamp located near the workstation is recommended for preparing and monitoring experiments. The workstation keyboard is backlit for working in low light situations.

You can press the BLANK SCREEN key on the keypad to darken the monitor for improved image quality. Pressing any key on the keyboard restores monitor function.

- 
1. IEC 61010-1: 2<sup>nd</sup> ed. International Electrical Commission defines POLLUTION DEGREE 2 as follows: "Normally only non-conductive POLLUTION occurs. Occasionally, however, a temporary conductivity caused by condensation must be expected."

## Dust

It is important to minimize dust on the microscope components because dust on components can cause spots on microscope images. Minimize contamination by maintaining a clean room and covering the microscope when it is not in use. Store all extra filter sets, cameras, objectives, plates, etc. away from dust.

## Overview of Components

The standard DeltaVision components are shown below. Detailed descriptions of these components and descriptions of optional components are included in the following sections.

### Standard DeltaVision Components



## Standard *personalDV* Components

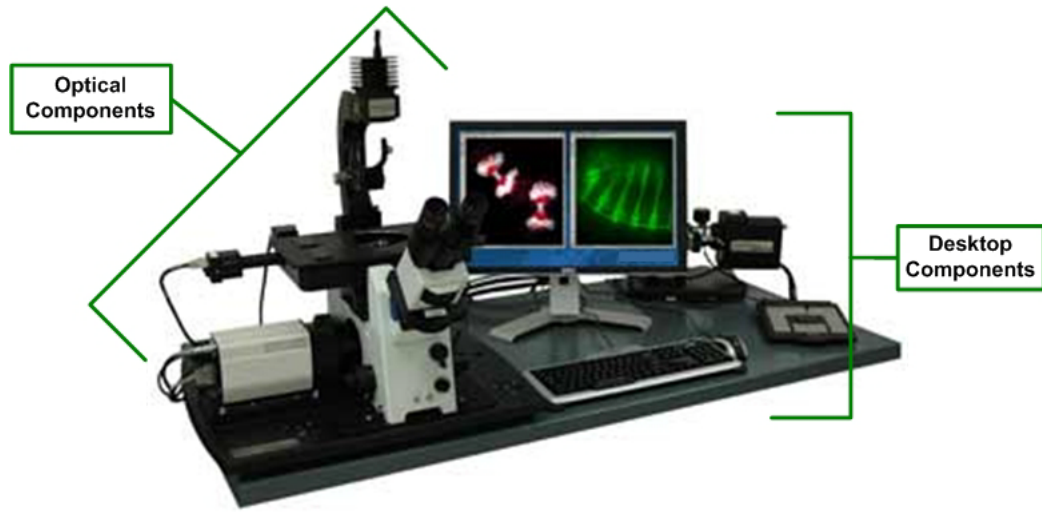

## Optical Components

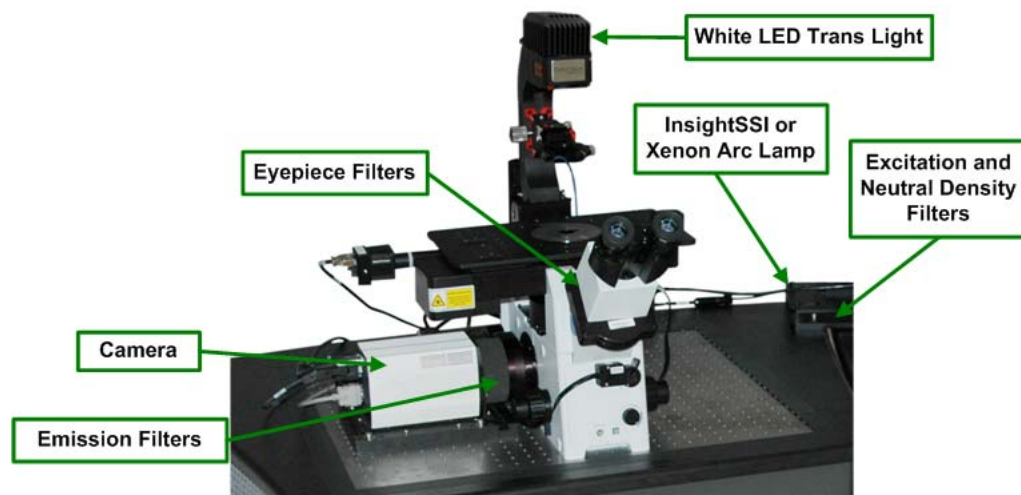

**Note** Optical components are shown for a typical installation, which includes the Olympus IX71 Microscope. Other microscope configurations vary slightly. The Olympus IX71 is currently the only microscope available with DeltaVision systems.

## Fluorescence Microscope

The microscope is an advanced research grade epifluorescence inverted microscope. Each objective is qualified by GE to guarantee the highest possible quality. The point

spread function (PSF) is measured in order to uphold the image quality. The microscope supports a Differential Interference Contrast (DIC) module as an optional component. A transmitted light is included with your system to enable automated DIC and Brightfield image acquisition.

## Optical Filters

The system uses a polychroic filter and filter wheels rather than a simple dichroic filter cube. The excitation, neutral density, and emission settings are selected in one of three ways:

- Selecting options in the Resolve3D window of the *softWoRx* acquisition software.
- Selecting a mode from the keypad.
- Rotating the eyepiece filter wheel (if Resolve3D is running).



**Note** The eyepiece filter wheel is operated manually but reports its position to the instrument controller, which in turn adjusts the excitation and emission filters automatically.

---

Depending upon the environment, filters last between one and three years. To ensure optimal performance, filters should be periodically inspected and replaced if necessary.

The Standard and Live Cell DeltaVision Filter sets are listed in *Appendix D, "Reference Information"* on Page D.1.

## Fluorescence Illuminators

A DeltaVision system can be configured with either an Olympus Fluorescence Illuminator or an Automated Fluorescence Illuminator. The key differences between the two fluorescence illuminators are outlined in the following sections.

### Olympus Fluorescence Illumination Module

The Olympus Fluorescence Illumination Module (Olympus FI) is attached to the rear of the DeltaVision imaging system. The Olympus FI is a less expensive choice for fluorescence illumination if you are *not* planning to use multi-line TIRF or the UltimateFocus Module. You are still able to use broadband light sources, such as Solid State Illumination (InsightSSI) or a xenon lamp. You will still be able to use the single-line TIRF technique, but you must have an optional laser module to do so. In general,

the configuration settings for the Olympus FI (field stop aperture, etc.) are set manually.

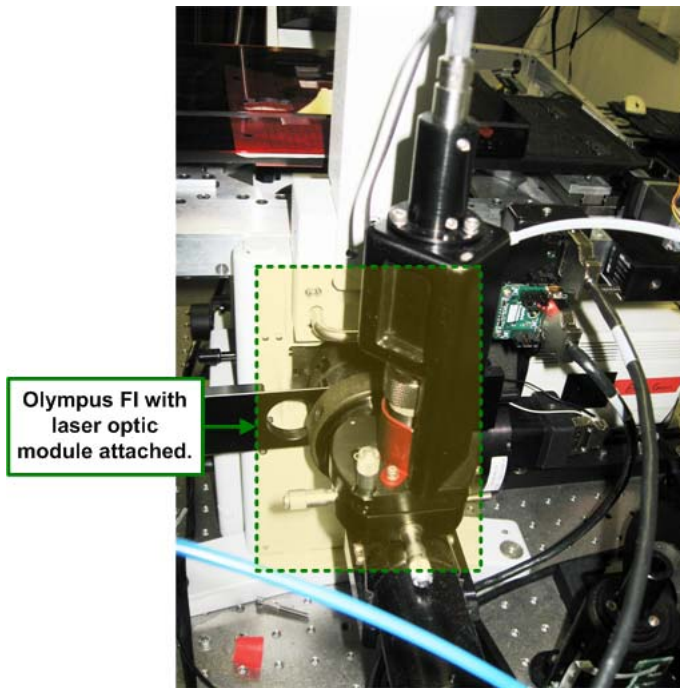

### **The Fiber Optic Module**

Use the Fiber Optic Module (FOM) to align the light path from the fiber optic cable to the Olympus Fluorescence Illuminator. This module allows you to adjust the tilt, horizontal, and vertical orientation of the light path.



Fiber Optic Module

### **Automated Fluorescence Illumination Module**

The Automated Fluorescence Illumination (Auto FI) Module is attached to the rear of the DeltaVision system and extends to the right side. The Auto FI Module is actually a

hardware interface that supports a combination of three smaller modules, each adding its own special utility to enhance the capabilities of the DeltaVision system. The Broadband Module (described below) is always included with the Auto FI Module. The TIRF/PK Module and the UltimateFocus Module are optional components. The configuration settings for the Auto FI Module are set up through software, which can be especially convenient if an Environmental Chamber is being used with the DeltaVision system. See *The Environmental Chamber* on Page 8.30 for details.

The three components that may be included with the Auto FI Module are as follows:

- The **Broadband Module** – is an input module for broadband light sources, such as Solid State Illumination (InsightSSI) or a xenon lamp. The Broadband Module provides a user-configurable illumination function for selecting either Critical or Kohler Illumination. The module also houses the beam conditioner, a field stop aperture, and a photo-sensor interface. The Broadband Module is standard on a DeltaVision system with the Auto FI Module installed.



**WARNING!** DO NOT disconnect or remove the fiber optic cable from the broadband module. Unless otherwise instructed by procedures in this manual or by an authorized GE representative, users should not disassemble any part of the DeltaVision Imaging System.

- 
- The **TIRF/PK Module** – provides the ability to introduce a laser beam into the optical path of the DeltaVision microscope. With lasers attached (like the X4 Laser Module), users can generate photokinetic events and TIRF (Total Internal Reflective Fluorescence) experiments. TIRF is an imaging method that illuminates a thin section of the sample. The excitation light emits from the objective at a shallow angle, enters into the cover slip, and bounces inside the cover slip creating an *evanescent* field of fluorescence. The TIRF/PK Module is available on a system with the Auto FI Module installed. For more information on the X4 Laser Module and the TIRF technique, see “X4 Laser Module and TIRF” on Page 8.41.



**Note** Your TIRF/PK Module may include TIRF only, PK only, or both TIRF and PK.

- 
- The **UltimateFocus™ Module** – maintains focus during an experiment, after the operator has found focus and marked a point of interest. The UltimateFocus Module uses an infrared laser that follows the illumination path and bounces off the cover slip/sample interface. The reflected beam is evaluated and the software returns an offset to the Z motor for automatic stage adjustment to maintain focus. The UltimateFocus Module is available on a DeltaVision system with the Auto FI Module installed.

Each of these components is mounted to the rear of the DeltaVision imaging system (while facing the microscope) as shown below.

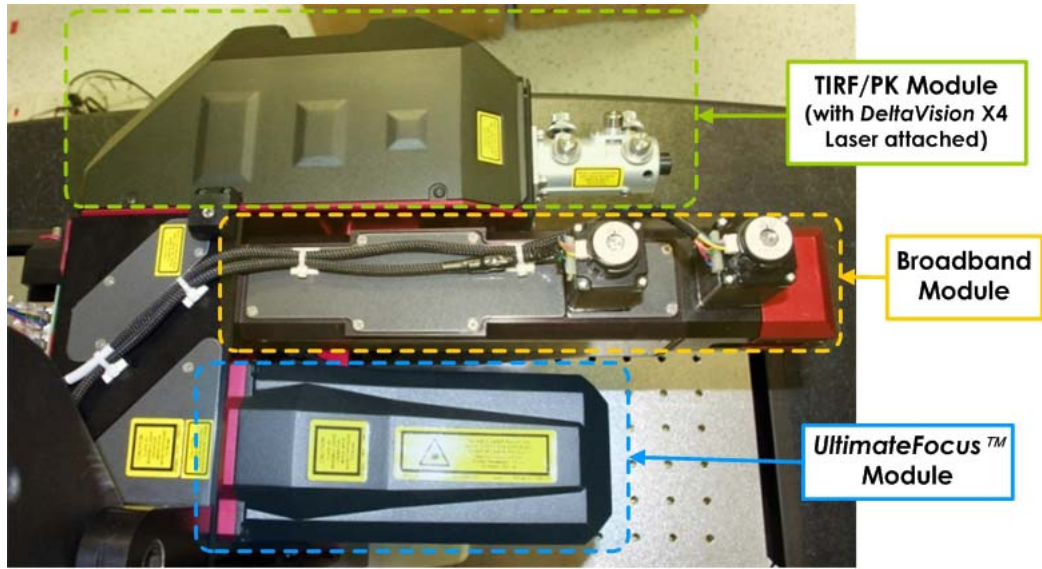

DeltaVision Fluorescence Illumination Module



**Note** Particularly when using the InsightSSI Solid State Illumination Module, you may find that you need to decrease the imaging system's illumination output by placing an additional neutral density (ND) filter directly into the Broadband Module. Pull up on the red ND Filter Holder (shown below) and insert an ND filter (p/n 52-852283-000-9).

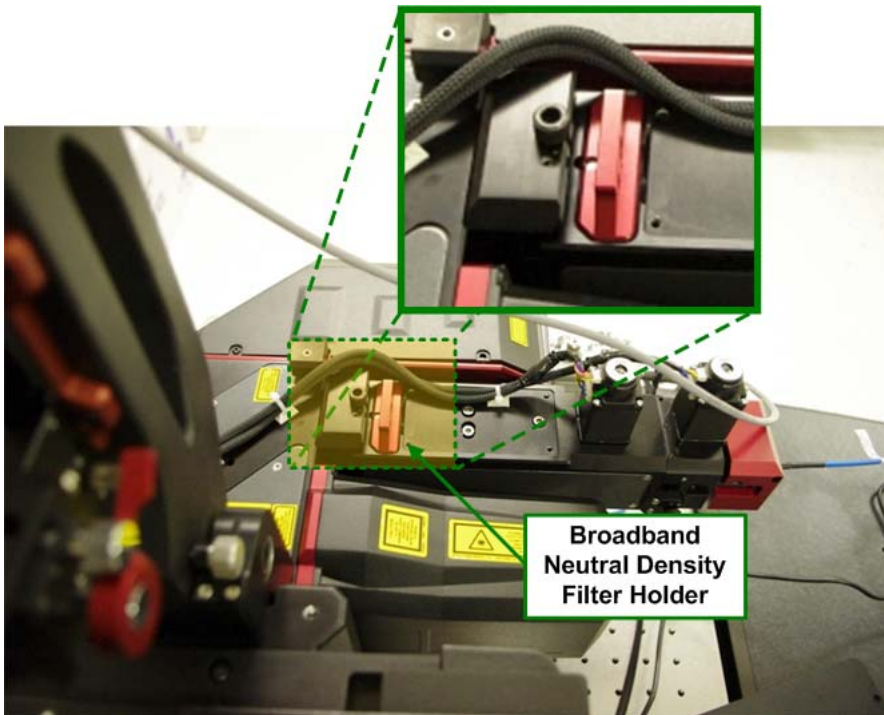

Broadband Neutral Density Filter Holder



## Cameras

DeltaVision supports several different camera models providing you with a range of options to meet your specific imaging needs. Possible camera models include the PCO Edge CMOS, the Evolve EMCCD, and the CoolSNAP HQ<sup>2</sup>. The following sections describe the benefits and key features of each type of camera supported.

### PCO Edge CMOS Camera

The PCO Edge CMOS Camera is capable of delivering extremely low noise, fast frame rates, a wide dynamic range (15-bit readout, camera switches to 12-bit readout with fields of view larger than 1024 X 1024), high quantum efficiency, high resolution, and a large field of view (up to 2048 X 2048). The PCO Edge also includes the capability of using a rolling shutter allowing for the fastest data collection speed possible with DeltaVision (~400fps for 512x512 pixels, single-channel, without Z scan). In general, the PCO Edge is the best camera choice if speed and sensitivity are your critical experimental variables.



PCO Edge<sup>®</sup> CMOS Camera

The PCO Edge camera's main features are:

- Low noise: 1.4 electrons
- High resolution: 5.5 megapixel
- High dynamic range: 22000:1
- High speed: 100 to 400fps (depending on experiment type)
- Free of drift: stabilized Peltier cooling in order to avoid any drift phenomena in image sequences



**Note** Using cooled cameras in humid conditions allows the possibility for condensation to form on the CCD camera window. If this happens, a mottled pattern is superimposed on the images. You will need to lower the ambient humidity level to avoid condensation.

---

## Configuring the PCO Edge sCMOS Camera for Fast Imaging

Complete the following procedures to optimally configure the PCO Edge sCMOS camera for fast imaging using the rolling shutter.

1. From the Resolve3D main menu, click the **Settings** icon. The Resolve3D Settings menu is displayed.

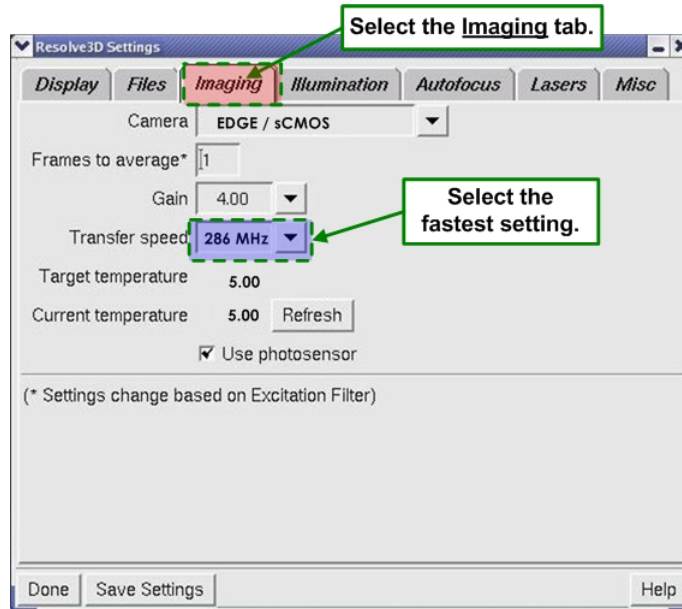

2. On the Resolve3D Settings menu, select the **Imaging** tab.
3. In the **Transfer speed** field, select the fastest setting available (usually 286 MHz).
4. From the Resolve3D main menu, click the **Experiment** button. The Design/Run Experiment window is displayed.

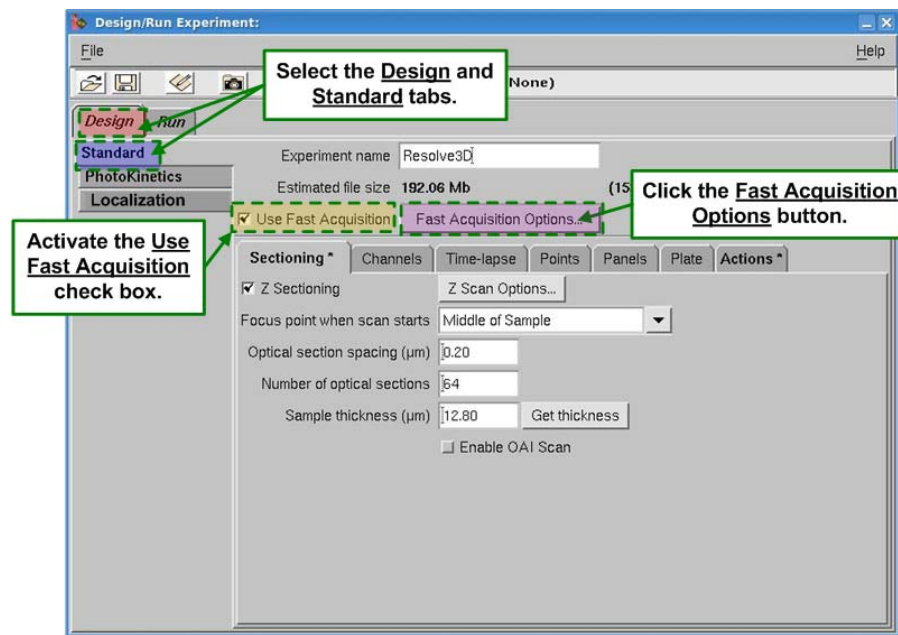

5. On the Design/Run Experiment window, make sure the **Design** tab and the **Standard** tab are active.
6. To achieve maximum frame rate, activate the **Use Fast Acquisition** check box.
7. Click the **Fast Acquisition Options** button to open the Fast Acquisition Options window.

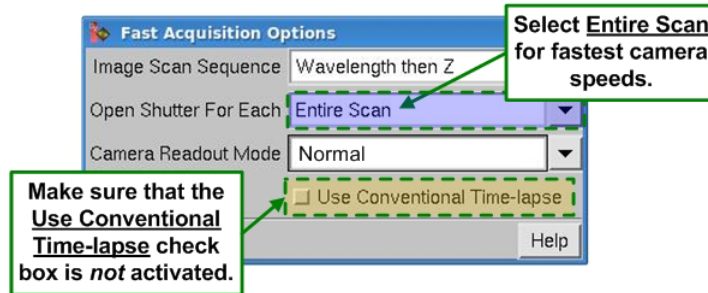

8. In the **Open Shutter For Each** field, select **Entire Scan** to enable the fastest camera speeds.
9. Ensure that the **Use Conventional Time-lapse** check box is not activated (no check mark).



**Note** Using Z sectioning or channel switching that requires motion of the stage or filter wheels will significantly slow down the frame rate. (Also, **Camera Readout Mode** has no effect on sCMOS speeds.)

10. From the Resolve3D main menu, click the **Experiment** button and then click on the **Run** tab to display the Design/Run Experiment window as shown.

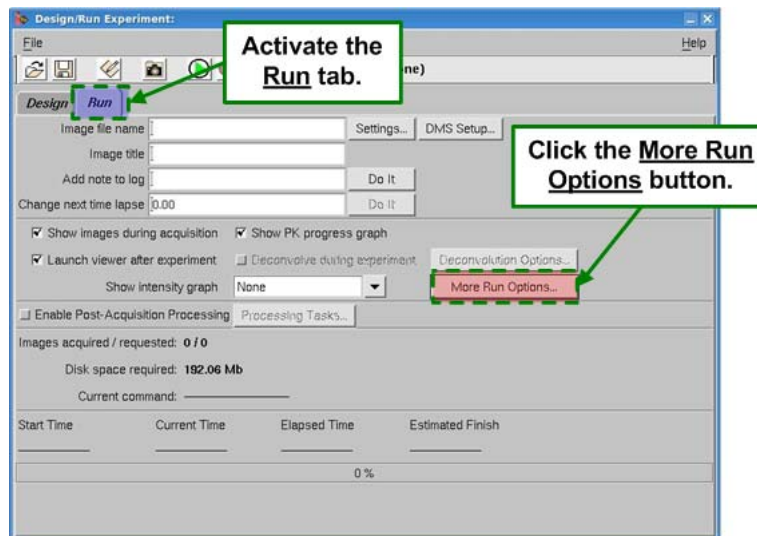

11. Click on the **More Run Options** button. The More Run Options window is displayed.

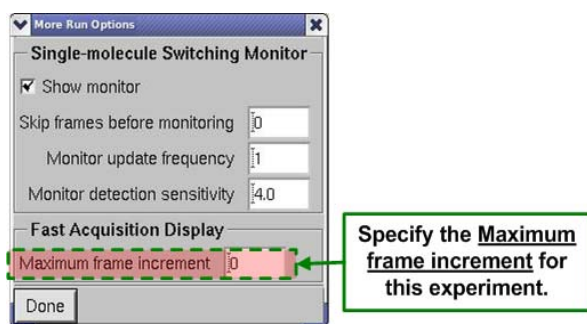

12. In the **Maximum frame increment** field of the More Run Options window, you can specify how many frames will be displayed when running fast experiments.



**Note** For fastest acquisition, it is recommended that you set the number in the **Maximum Frame Increment** field as high as possible (up to the total number of frames being acquired).

A value of 0 forces each frame to be displayed as it is collected. A value of 10 would display only each 10th frame. It is important to note that this only affects the display of the images as they are collected. All of the images are saved to the data file regardless of the **Maximum frame increment** setting.

### Application Tips

The following is a list of tips for using the PCO Edge sCMOS camera with a high-speed DeltaVision system.

- 15-bit camera - 32,767 counts is saturation (12-bit camera for fields of view larger than 1024 X 1024)
  - Fixed samples - Aim for 5000 to 6000 counts as max intensity.
  - Live samples - Use 2X to 3X counts of signal above background.
- To overcome photobleaching or photo-toxicity:
  - Consider using the **95MHz** option in the **Transfer Speed** field on the **Imaging** tab of the Resolve3D Settings window to reduce read noise.
  - Binning only averages photons (instead of summing) from binned pixels. It cannot be used to amplify the signal, but it can be used to increase the readout speed.
- Köhler illumination should be used with fields of view larger than 1024 X 1024. On average, Köhler illumination requires 4 times the amount of exposure time to achieve the same image intensity. Flat field calibration is recommended.

## CoolSNAP HQ<sup>2</sup> CCD Camera

The CoolSNAP HQ<sup>2</sup> camera from Photometrics is a 12-bit camera designed to collect data at a high frame rate and a maximum field of view of 1024 X 1024 pixels. You can vary field of view size as well as additional experimental parameters to optimize camera performance to fit your data requirements.

The high frame rate of the CoolSNAP HQ<sup>2</sup> is useful when collecting images of live cells that deteriorate over short periods of time.

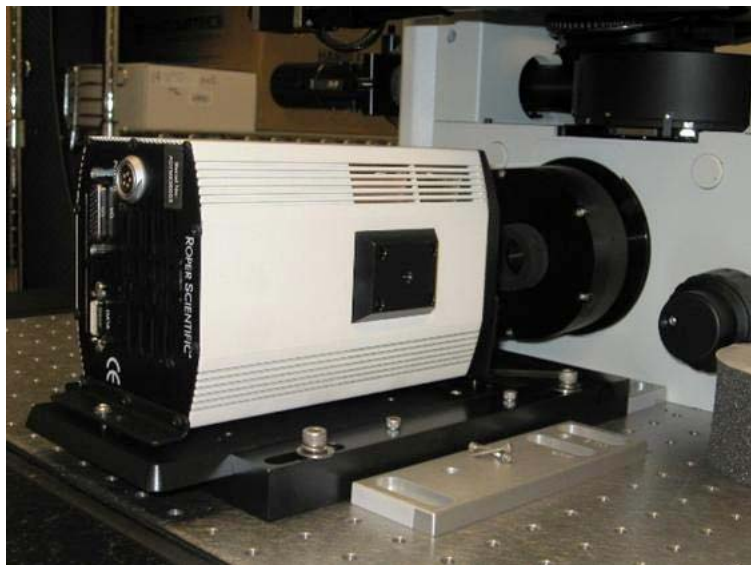

#### CoolSNAP HQ<sup>2</sup> CCD Camera

The CoolSNAP HQ<sup>2</sup> camera is air-cooled to a temperature of -30C. The cooling apparatus is incorporated into the camera head assembly. This kind of design means that the cooler can only be operating when the camera is powered on.



**CAUTION!** Do not disconnect cables from the CoolSNAP HQ<sup>2</sup> camera when the power is on. Be sure to leave a 1 in (2.5 cm) minimum space around the cooling fan. Use only the cables and power supplies that are designated for this system.



**Notes 1)** If no images are acquired over a 4-hour period, the CoolSNAP HQ<sup>2</sup> camera cooling automatically shuts down.

**2)** Using cooled cameras in humid conditions allows the possibility for condensation to form on the CCD camera window. If this happens, a mottled pattern is superimposed on the images. You will need to lower the ambient humidity level to avoid condensation.

#### Application Tips

The following is a list of tips for using the CoolSNAP HQ<sup>2</sup> CCD camera with a high-speed DeltaVision system.

- For a 12-bit camera, 4095 counts is saturation
  - Fixed sample imaging - Aim for 2000-3000 counts as max intensity.
  - Live sample imaging - Use 2X to 3X counts of signal above background.
- To overcome photobleaching or photo-toxicity:

- Use **2x2** binning to improve the maximum intensity in the data readout. (Binning sums the intensities of the binned pixels to make 1 pixel in the raw data.)
- Use the **Gain** setting of **4x** to amplify intensity.

## ES<sup>2</sup> CCD Camera

The CoolSNAP ES<sup>2</sup> CCD Camera is similar to the CoolSNAP HQ<sup>2</sup> Camera, except the ES<sup>2</sup> is not as deeply cooled. This makes it more affordable, but it also yields slightly higher noise. The noise difference is virtually unnoticeable unless you are using long exposure times (>7s).



**Note** Using cooled cameras in humid conditions allows the possibility for condensation to form on the CCD camera window. If this happens, a mottled pattern is superimposed on the images. You will need to lower the ambient humidity level to avoid condensation.

---



CoolSNAP ES<sup>2</sup> CCD Camera

## Photometrics Evolve Camera

The Evolve camera from Photometrics is a 16 bit EMCCD camera with a maximum field of view size of 512x512 pixels. The EMCCD chip in the Evolve camera is a back-thinned chip and the camera is air cooled to -70C to ensure high performance and minimal noise in the EMCCD data readout. The Evolve camera is typically considered for applications in which you cannot afford to expose your specimen to much light and need more than just

binning or gain to get a usable level of intensity out of your sample without compromising the biology.



Photometrics® Evolve Camera

The Evolve Camera was designed by Photometrics to perform very well in low-light applications and is therefore an excellent camera for live-cell imaging. This camera also reads out pixel data in electrons, resulting in more accurate and reproducible data. Some of the key features of the Photometrics Evolve Camera are:

- EM gain
- Back-illuminated EMCCD
- Optimized field of view and very high sensitivity
- PAR feedback system
- ACE (Advanced Clocking Enhancement) technology
- 10-MHz readout
- 5- and 1- readout
- Dual amplifiers
- 16-bit digitization

The Evolve camera is displayed on the **Imaging** tab of the softWoRx Settings menu as two cameras:

- **Conventional** readout mode is the most efficient readout mode of any DeltaVision camera option at greater than 85%. This mode is recommended for use if you have a strong, stable signal that does not require the use of the EM gain. There are two read-out speed options for the conventional mode:
  - 1MHz
  - 5MHz (There is a slight trade-off of noise for the faster 5MHz readout speed.)
- **Electron Multiplying** readout mode is used when your experiments require pushing the limit of signal over noise. The range of the Evolve camera gain

options is 1-1000, with a recommended "sweet-spot" between 150-200 to ensure maximal signal benefit over noise contribution. There are two readout speed options for the Electron Multiplying mode:

- 5MHz
- 10MHz (There is a slight trade-off of noise for the faster 10MHz readout speed.)

An additional feature built into the Evolve camera is the *Rapid-Cal* Calibration, which should be used routinely to ensure that, as the EMCCD chip ages, you are applying consistent gain values.

#### To run the calibration:

1. Turn off the IC/MIC, leaving the camera power on.
2. Turn the front silver wheel labeled "Rapid-Cal" until it locks into position and the LED indicator light comes on. The light should blink amber for up to several minutes, indicating a calibration is occurring. The light will change to a solid green light once the calibration is complete.
3. When the indicator light is green, turn the calibration wheel back to the open, imaging position and then re-initialize the DeltaVision.



**Note** Using cooled cameras in humid conditions allows the possibility for condensation to form on the CCD camera window. If this happens, a mottled pattern is superimposed on the images. You will need to lower the ambient humidity level to avoid condensation.

---

#### Application Tips

The following is a list of tips for using the Photometrics Evolve camera with a high-speed DeltaVision system.

- For a 16-bit camera, 65535 counts is saturation
  - Fixed sample imaging - Aim for 12000-15000 counts as max intensity.
  - Live sample imaging - Use 2X to 3X counts of signal above background.
- Choose experiment-specific camera readout settings
  - Use the **Conventional** readout option for bright samples that do not require signal amplification.
  - Use the **Electron Multiplying** readout to overcome photobleaching or photo-toxicity. Use a **Gain** setting between 150-200 to optimally utilize the electron multiplying benefit over noise contribution.
- Run the Photometrics Rapid-Cal process once a month to ensure consistency of applied gain over time.

#### Light Sources

A DeltaVision imaging system provides at least two, and sometimes three light sources: either a solid state illumination (InsightSSI) module or a xenon arc lamp for the broadband light source, a white LED for transmitted light, and an optional laser module for laser-based light.





**Note** A DeltaVision system can optionally be configured with both broadband light sources (InsightSSI and a xenon arc lamp). Note that only one broadband light source can be used at any given time.

---

### Xenon Lamp

One of the choices offered for a DeltaVision broadband light source is the xenon arc lamp. Illumination for the microscope is delivered from a xenon lamp to the specimen through a fiber optic cable.

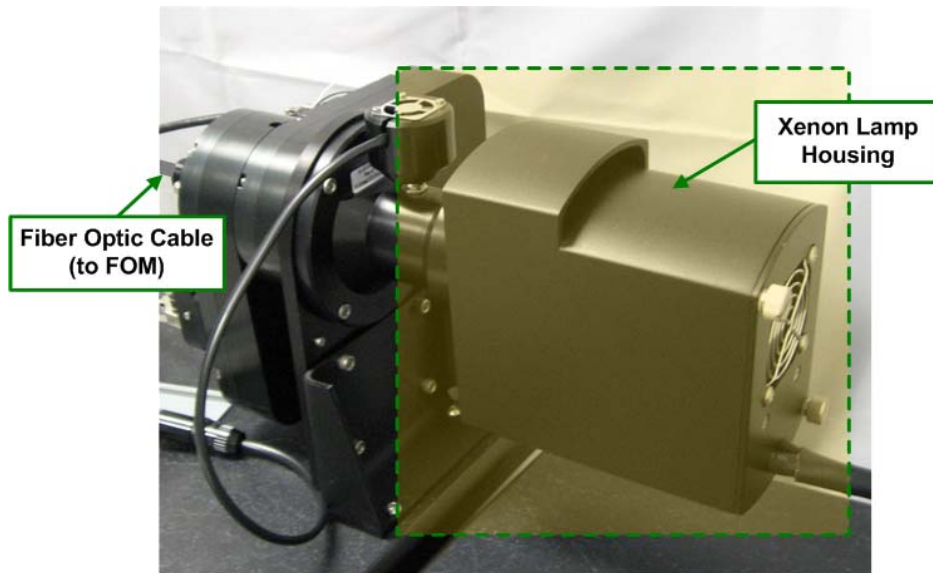

**Xenon Lamp Housing**

For instructions on how to replace the xenon bulb, see “Replacing the Xenon Bulb” on Page 10.3.



**WARNING!** Do not disconnect the xenon arc lamp power cable when the power is on.

---



**WARNING!** The xenon arc lamp presents potentially harmful risks to the user, including the possibility of UV exposure to skin and eyes. Before operating the microscope, consult *Chapter 2: Safety* for important information regarding arc lamp operation.

---



**Note** The illumination path alignment is critical to acquiring the highest possible image resolution. If you have reason to suspect that the illumination path alignment is inaccurate for your DeltaVision system, contact your GE representative.

---

### **Photo sensor and Checking Illumination Consistency**

Most light sources do not always provide consistent illumination. DeltaVision incorporates a photo sensor that measures and stores relative intensities during acquisition. The illumination light passes through the fiber optic module (FOM), where approximately 1% of the light is diverted to the Photo sensor. The remaining 99% of the light is delivered to the microscope. The Photo sensor measures illumination intensity by sampling a small percentage of the light from the broadband light source during an exposure. The photo sensor signal is recorded by the instrument controller and then used to correct for variations in the xenon lamp intensity during an experiment.

The Corrections tool in *softWoRx* normalizes each image based on its photo sensor value. These corrections are automatically applied during deconvolution. This enables quantifiable intensity comparisons between images, even if the brightness of the excitation light varies between the images.

### **InsightSSI (Solid State Illumination)**

The InsightSSI Module, another choice offered for a DeltaVision broadband light source, adds a solid state light source to your imaging system. Because the light produced by the InsightSSI Module is solid state and can be switched on and off very quickly, no shutters are necessary for imaging. The InsightSSI Module increases power across all wavelengths. This feature can greatly reduce exposure times. Not having to wait for a xenon bulb to stabilize is another advantage of using a solid state light source. The InsightSSI Module turns on and off instantly.



**Four-color InsightSSI Module**

Depending on the type of imaging you plan on doing, the InsightSSI Module is available with a choice of three different excitation filter sets:

- Four-color InsightSSI Module – for fixed cell applications
- Four-color InsightSSI Module – for live cell applications
- Seven-color InsightSSI Module – for both fixed and live cell applications

Seven-color *InsightSSI* Module



The three available filter sets are detailed in the following tables:

#### Four-color Standard Filter Set







Wavelengths (nm)	Suggested Fluorophores
● 381-399	DAPI, Hoechst, Alexa Fluor <sup>®</sup> 350, Dylight <sup>™</sup> 350, CF <sup>®</sup> 350, Cascade Blue, Lucifer Yellow, AMCA, CellTracker <sup>®</sup> Blue, all Qdot <sup>®</sup> nanocrystals
● 461-489	FITC, Alexa Fluor <sup>®</sup> 488, Dylight <sup>™</sup> 488, CF <sup>®</sup> 488, Oregon Green 488, Calcium Green, Flou-3, Flou-4, CellTracker <sup>®</sup> Green, Rhodamine 123, MitoTracker <sup>®</sup> Green, LysoTracker <sup>®</sup> Green
● 529-556	TRITC, Cy3 <sup>®</sup> , Alexa Fluor <sup>®</sup> 546, Alexa Fluor <sup>®</sup> 555, Alexa Fluor <sup>®</sup> 568, Dylight <sup>™</sup> 549, CF <sup>®</sup> 555, MitoTracker <sup>®</sup> Orange
● 621-643	Cy5 <sup>®</sup> , Cy5.5, APC, Alexa Fluor <sup>®</sup> 647, Alexa Fluor <sup>®</sup> 635, Alexa Fluor <sup>®</sup> 660, Dylight <sup>™</sup> 633, Dylight <sup>™</sup> 649, CF <sup>®</sup> 633, CF <sup>®</sup> 647, MitoTracker <sup>®</sup> Deep Red

#### Four-color Fluorescent Protein Filter Set

Wavelengths (nm)	Fluorescent Proteins	Suggested Fluorophores
● 426-450	CFP	Pacific Blue <sup>™</sup>
● 461-489	GFP, EGFP	FITC, Alexa Fluor <sup>®</sup> 488, Dylight <sup>™</sup> 488, CF <sup>®</sup> 488, Oregon Green 488, Calcium Green, Flou-3, Flou-4, CellTracker <sup>®</sup> Green, Rhodamine 123, MitoTracker <sup>®</sup> Green, LysoTracker <sup>®</sup> Green

 505-515	YFP	Alexa Fluor 532
 563-588	mCherry	Alexa Fluor <sup>®</sup> 568, Alexa Fluor <sup>®</sup> 594, Dylight™ 594, MitoTracker <sup>®</sup> Orange, MitoTracker <sup>®</sup> Red, LysoTracker <sup>®</sup> Red, CellTracker <sup>®</sup> Red

### Seven-color Combined Filter Set

Wavelengths (nm)	Fluorescent Proteins	Suggested Fluorophores
 381-399	BFP	DAPI, Hoechst, Alexa Fluor <sup>®</sup> 350, Dylight™ 350, CF <sup>®</sup> 350, Cascade Blue, Lucifer Yellow, AMCA, CellTracker <sup>®</sup> Blue, all Qdot <sup>®</sup> nanocrystals
 426-450	CFP	Pacific Blue™
 461-489	GFP, EGFP	FITC, Alexa Fluor <sup>®</sup> 488, Dylight™ 488, CF <sup>®</sup> 488, Oregon Green 488, Calcium Green, Flou-3, Flou-4, CellTracker <sup>®</sup> Green, Rhodamine 123, MitoTracker <sup>®</sup> Green, LysoTracker <sup>®</sup> Green
 505-515	YFP	Alexa Fluor 532
 529-556	OFP, RFP, DsRed	TRITC, Cy3, Alexa Fluor <sup>®</sup> 546, Alexa Fluor <sup>®</sup> 555, Alexa Fluor <sup>®</sup> 568, Dylight™ 549, CF <sup>®</sup> 555, MitoTracker <sup>®</sup> Orange
 563-588	mCherry	Alexa Fluor <sup>®</sup> 568, Alexa Fluor <sup>®</sup> 594, Dylight™ 594, MitoTracker <sup>®</sup> Orange, MitoTracker <sup>®</sup> Red, LysoTracker <sup>®</sup> Red, CellTracker <sup>®</sup> Red
 621-643		Cy5 <sup>®</sup> , Cy5.5, APC, Alexa Fluor <sup>®</sup> 647, Alexa Fluor <sup>®</sup> 635, Alexa Fluor <sup>®</sup> 660, Dylight™ 633, Dylight™ 649, CF <sup>®</sup> 633, CF <sup>®</sup> 647, MitoTracker <sup>®</sup> Deep Red

A critical advantage of using the InsightSSI Module for your DeltaVision system's broadband light source instead of the xenon lamp is speed. When mechanical shutters are eliminated from the system, shorter exposure times can be achieved.



**Note** Additional high-speed polychroic options are available for the four-color fluorescent protein InsightSSI and the seven-color InsightSSI.

## LED Transmitted Light

An LED transmitted light source is also provided.



LED Transmitted Light Source



**Note** Most of the DeltaVision light sources (the xenon lamp, solid state illumination, or the LED transmitted light) can be used with the eyepieces or the cameras. Lasers cannot be used with the eyepieces.

## Desktop Components

Desktop Components include the flat panel display monitor, the keyboard, the mouse, the keypad/joystick. DeltaVision includes a vibration isolation table. *personalDV* includes a bench-top microscopy isolation platform.

### Flat-Panel Display Monitor

All DeltaVision systems are equipped with Flat-Panel LCD monitors. These monitors offer a very high level of performance in several areas pertaining to the quality of displayed images, the most critical of which is contrast ratio.

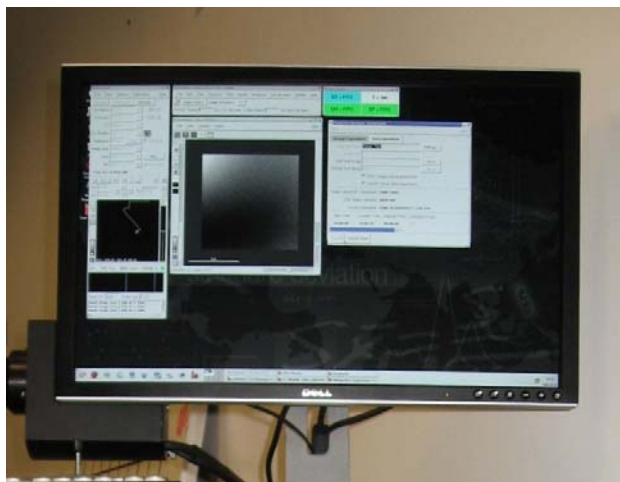



**Note** For instructions that show how to adjust the monitor, see the Flat-Panel Display manual.

---



**CAUTION!** DeltaVision is configured to work with the monitor that is included with the system. Other monitors are not necessarily supported.

---

## The Keypad and Joystick

Many of the functions accessible through Resolve3D are also available on the keypad/joystick (see “Keypad/Joystick Operation” on Page E.44).



## Vibration Isolation Table

Within the vibration isolation table is a breadboard surface that is supported by mechanical vibration isolators. These components provide optimal performance without an external air source. The isolators are sized for the system weight as delivered. If significant additional weight is added to the breadboard, higher capacity isolation may be required. Contact your GE representative for more information.



**Note** The vibration isolation table is not included with personalDV. Instead, personalDV includes a bench-top isolation platform to provide similar stability for the microscope. The DeltaVision vibration isolation table is available for personalDV as an optional upgrade.

---

## Cabinet Components



**Note** The component cabinet is included with DeltaVision only. The cabinet is not available for personalDV.

The cabinet contains all of the electronic control equipment and provides surfaces for the keyboard and the Flat Panel Display. The front two wheels should remain locked and the cabinet left in place. There are many cables connecting the microscope that can be damaged if they are pulled. The standard cabinet components are shown below.

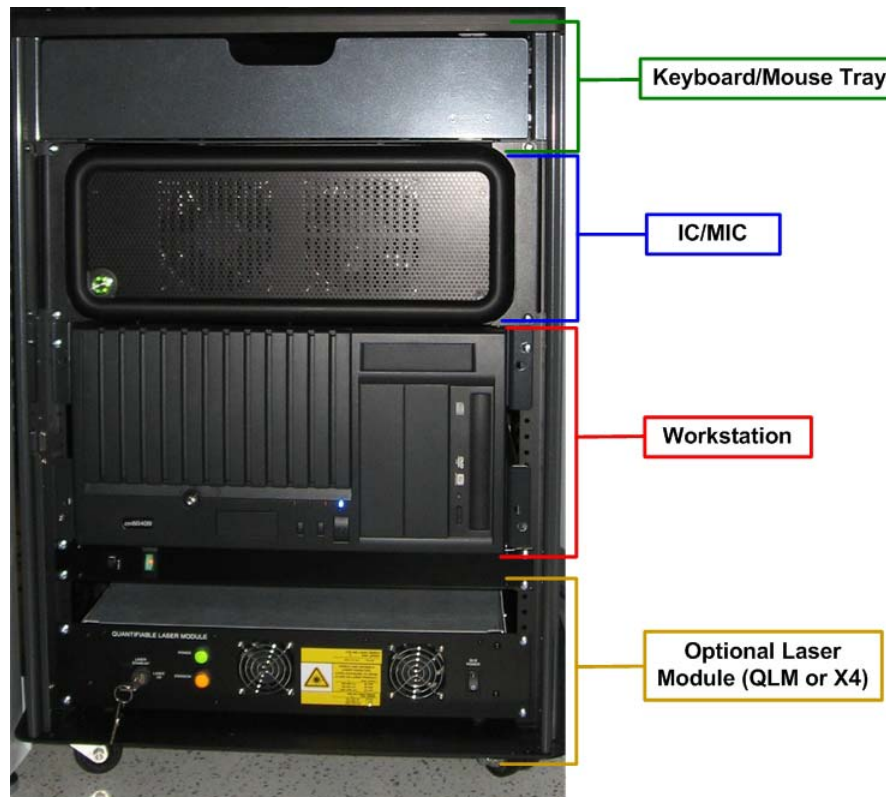

Cabinet Components



**Note** Configuration of DeltaVision cabinet components may vary slightly.

## Instrument Controller / Microscope Interface Chassis (IC/MIC)

The Instrument Controller (IC) is the portion of the computer that interfaces with all of the microscope hardware (including the microscope stage motors, filter wheel motors, and cameras). It coordinates all activities related to positioning the stage and collecting images. Data from the camera feeds through the controller to the workstation. The

controller also receives instructions from the workstation and issues commands to the motors through the Microscope Interface Chassis.

The Microscope Interface Chassis (MIC) side of the computer provides power and control for the filter motors, stage drive, and shutters. It also contains the Photo sensor, which is connected to the microscope through a fiber optic cable.

**Notes**

**#1** The Instrument Controller/Microscope Interface Chassis has no user-serviceable parts inside.

**#2** Occasionally, you may need to replace fuses on the back panel of the chassis. Consult Chapter 9 for a description of this procedure. Unless there is an obvious reason why the fuse blew, you should contact GE Customer Service when you need to replace fuses.

---

## Workstation

The workstation hosts the *softWoRx* application that is the primary interface used to control the DeltaVision system..



**Note** The workstation has no user-serviceable parts inside.

---

## Other Standard Components

Other standard components include the Repeatable Slide Holder, the Slide Holder Adapter, and the Fiber Optic Module.

### The Repeatable Slide Holder

The Repeatable Slide Holder holds the slide on the stage. It also allows you to move the slide across the stage and to mark the slide position when you remove the slide.

The ability to move the slide across the stage allows you to view the full slide on the 1" x 1" stage area. With the slide held against the three brass locators by the Return Spring, you can use the Slide Adjustment Knob to move the slide laterally.

Marking the position of your slide is useful when you are conducting a point visiting experiment and you need to remove the slide before you are finished. You can use the Position Indicator (the letter scale at the bottom of the slide holder) to record the position of your slide. When you resume your experiment, you can place the slide in the position that you recorded.



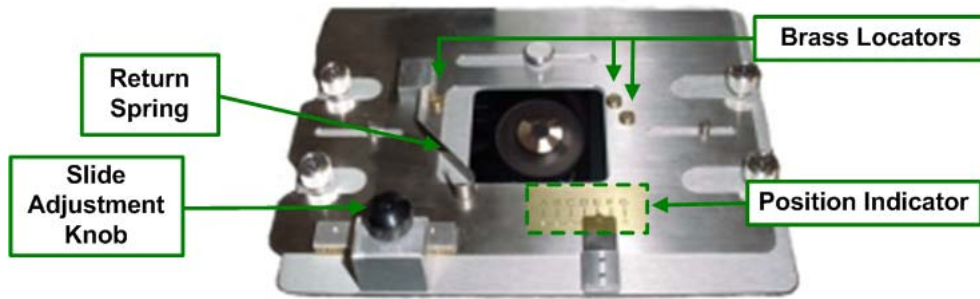

The Repeatably Slide Holder



**Note** If you are using a Petri dish or any other format that is not similar to a 1" x 3" slide, you will need to remove the Repeatably Slide Holder or use the Slide Holder Adapter.

For more about using the Repeatably Slide Holder, see *"Finding a Specimen and Recording its Slide Holder Position"* on Page 7.1.

## Slide Holder Adapter

The Slide Holder Adapter holds a chambered coverglass. It is mounted on the Repeatably Slide Holder. NUNC Lab-Tek™ II chambered coverglass with one, two, four, or eight wells are available. The Slide Holder Adapter also supports Petri dishes from 25 – 40 mm in diameter.



Slide Holder Adapter

## Calibration Kit

The Calibration Kit is provided for calibration operations on the DeltaVision system. The kit includes the following six slides:

- Three plastic fluorescent calibration slides – for flat-field calibration:
  - Blue plastic (EX 408nm, EM 440 nm) – Good for DAPI, Hoechst, etc.

- Orange plastic (EX 488nm, EM 519nm) – Good for FITC, GFP, TRITC, CY-3<sup>®</sup>, etc.
- Red plastic (EX 590nm, EM 650nm) – Good for CY-5<sup>®</sup>, etc.
- Silicon mirror slide – for light path alignment and troubleshooting.
- Silicon grid slide – for pixel size measurement.
- 100nm Rhodamine<sup>®</sup> bead slide – for PSF measurement.

## The Tool Kit

A tool kit provided with all DeltaVision systems includes tools for maintaining the system. This kit includes:

- Ties and belts for suspending cables, screws, and other fasteners
- Cleaning material (Q-tips and lens paper)
- A hex wrench set (5/64" – 3/16")
- A set of metric L keys (1mm –5mm)
- A #1 Phillips screwdriver
- A 5mm T Handle hex key
- An acrylic bulls eye level
- A micrometer nut wrench

## Software

All DeltaVision systems include *softWoRx* for Linux (1 copy).



**Note** DeltaVision systems can be ordered with a number of different software configurations. Talk with your GE representative to determine the best configuration for your applications.

---

### **softWoRx**

*softWoRx* is the Linux software application that runs the acquisition workstation. The software allows you to perform the following tasks:

- Acquire image data
- Set up and run experiments
- Deconvolve data
- Measure point spread functions
- Calculate optical transform functions
- Process 2-D and 3-D images
- Perform quantitative analysis
- Archive data
- Configure task chains
- Manage user accounts

## Optional Components

You can purchase several optional DeltaVision components. Some options are available for all DeltaVision systems, but many are available only for specific DeltaVision models. Check with your GE representative for details.

- The **Environmental Chamber** provides a controlled temperature environment for live cell imaging. The chamber also supports CO<sub>2</sub> injection, which allows you to control humidity and pH by maintaining a CO<sub>2</sub> flow over the sample. For additional information about the Environmental Chamber, see Page 8.30.
- **Microtiter Stage** for DeltaVision provides the system with the ability to scan microtiter plates. For more details on the Microtiter Stage, see Page 8.37.
- **Additional Filter Modules** can be loaded with custom filters or with the Live Cell filter set to provide greater flexibility for your lab. For more information about these Filter Modules, see Page 8.7.
- The **X4 Laser Module** adds multi-line TIRF (Total Internal Reflection Fluorescence), Fluorescence Recovery After Photo-bleaching (FRAP) analysis, and other photokinetic experiment capabilities to your DeltaVision system. TIRF is an optical technique in which laser light is introduced to the microscope in a way that limits fluorescence imaging to a thin area at the surface of the substrate. Typically, the TIRF sample is only illuminated 100-200nm into the specimen, resulting in an enhanced signal-to-noise ratio and increased imaging contrast. For more information on the X4 Laser Module and the TIRF technique, see “X4 Laser Module and TIRF” on Page 8.41. For details on FRAP analysis, see “*Analyzing Fluorescence Recovery After Photo-bleaching*” in the *softWoRx Imaging Workstation User’s Manual*.
- The **InsightSSI (Solid State Illumination) Module** is a solid state light source available for DeltaVision systems. The InsightSSI Module is available with either a set of four wavelengths for fixed cell imaging *or* a set of four wavelengths for live cell imaging, or seven wavelengths for both fixed *and* live cell imaging. For more information about the SSI Module, see “InsightSSI (Solid State Illumination)” on Page 8.20.
- The **Evolve EMCCD-type Camera** is an optional camera that provides high signal-to-noise ratios for low-light fluorescence, TIRF, or single molecule fluorescence. For more information on the Evolve Camera, see Page 8.16.
- The **PCO Edge CMOS Camera** has extremely fast frame rates and offers a wide dynamic range. This is the camera supported for use with DeltaVision in localization experiments. For more information about this camera, see “PCO Edge CMOS Camera” on Page 8.11.
- The **UltimateFocus Module** is a tool for maintaining focus during an experiment. After the operator has found the proper focus and marked a point of interest, the UltimateFocus Module maintains focus during the experiment. The UltimateFocus Module uses an infrared laser that follows the illumination path and bounces off the cover slip/sample interface. The reflected beam is evaluated and the software returns an offset to the Z motor for automatic stage adjustment to maintain focus. The UltimateFocus Module is optional for most DeltaVision systems. For more information on the UltimateFocus Module,

see "The UltimateFocus Module" on Page 8.46 and "Using UltimateFocus" on Page 7.39.

- **Analysis Workstations** include the *softWoRx* Linux workstation and the *softWoRx Suite* Windows workstation. For further information on these workstations, see Page 8.26.
- Available software includes two optional modules for DeltaVision systems: the **softWoRx Explorer** option and the **softWoRx Suite** advanced option. More information on software options is provided in "Software" on Page 8.28.
- A selection of **Differential Interference Contrast (DIC)** components are supported by DeltaVision systems. For alignment and setup details, see "Differential Interference Contrast (DIC) Module" on Page 8.47.
- The following **Optional Objectives** are tested by GE to ensure that they meet our rigid quality standards.

Optional Objectives
U-APO 40X Oil, 0.65-1.35NA, 0.10mm WD
U-PLAN S-APO 100X Oil, 1.4NA, 0.12 WD
U-PLAN APO 60X W/PSF Water, 1.20 NA, 0.25mm WD

The following subsections describe each of the optional DeltaVision components.

## The Environmental Chamber

Environmental control is an essential factor in live-cell microscopy or any other type of experiment requiring system stability. Focus instability can be difficult to resolve for critical experiments. Small changes in ambient temperature can lead to thermal expansion or contraction in the microscope stand, the stage, or the objective. These subtle changes can completely shift the optimal plane of focus. The Environmental Chamber is

designed to precisely control temperature and CO<sub>2</sub> levels making it ideal for long term time-lapse applications and high-resolution imaging.

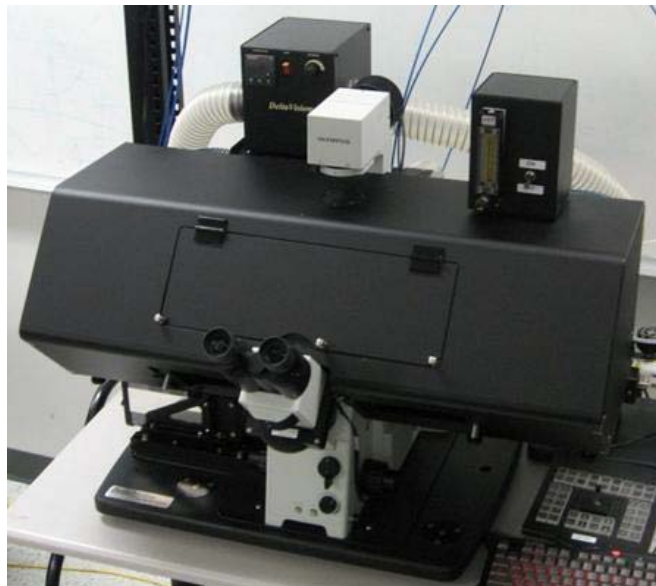

**Environmental Chamber - Opaque**

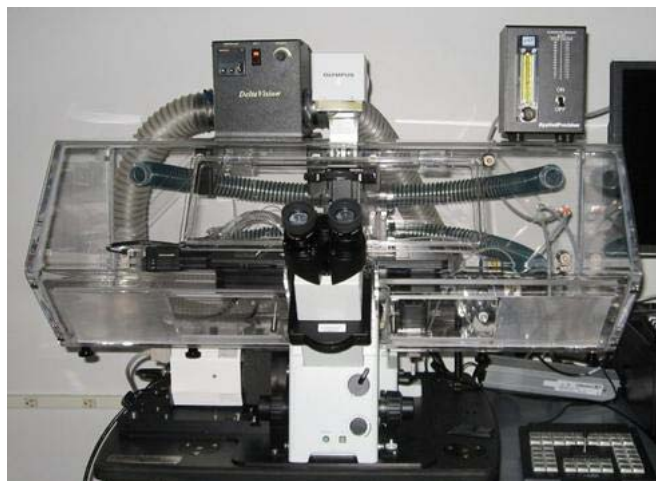

**Environmental Chamber - Transparent**

The Environmental Chamber includes a temperature controller, a CO<sub>2</sub> humidifier, and a CO<sub>2</sub> chamber. This product is generally installed by a trained GE service representative.

### **Basic Environmental Chamber Components**

Use the functional descriptions in this section for a basic understanding of the utility provided by the Environmental Chamber option installed on a DeltaVision system.

### Temperature Controller

The power switch for the temperature controller is on the back panel next to the power cord connection (see below). This switch controls the main power for the fan, the heater, and the microprocessor controller.

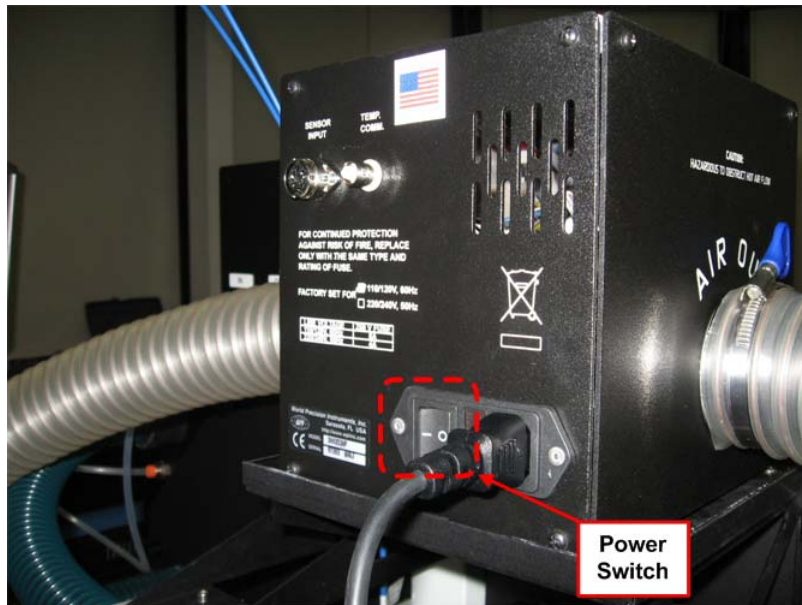

Temperature Controller Power Switch

The Heater Switch on the front panel of the temperature controller controls only the heater. When the Heater Switch is off and the Power Switch is on, the fan and microprocessor controller are still powered.

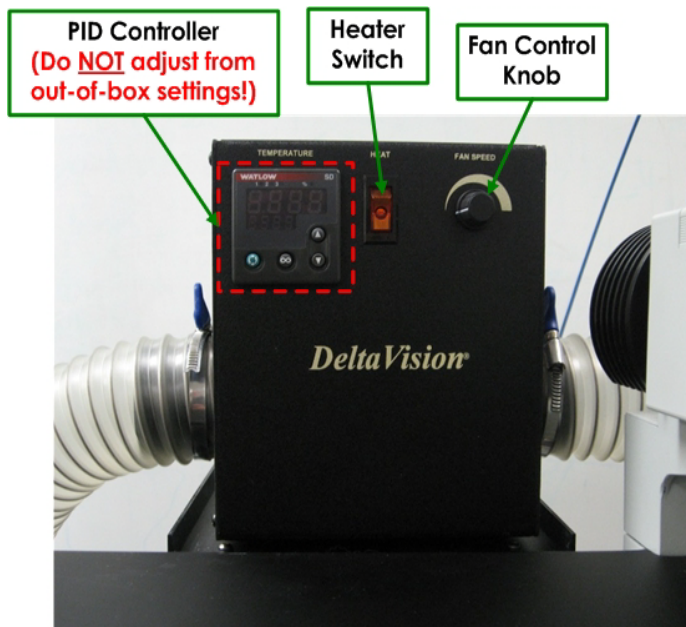

Heater Switch and Fan Control Knob

The temperature controller is preset for use with DeltaVision Environmental Chamber by default. The out-of-the-box settings for the PID controller should not be changed. All testing and calibration have been performed using the preset configuration. (PID denotes Proportional, Integral, and Derivative values. These values can be interpreted in terms of time: *P* depends on the *present* error, *I* on the accumulation of *past* errors, and *D* is a prediction of *future* errors, based on the current rate of change.)



**CAUTION!** Changing the settings on the PID controller from the default configuration may cause problems when using the device for the Environmental Chamber on a DeltaVision system.

### Fan Control Knob

The Fan Control Knob on the front panel adjusts the airflow rate from 20 to 50 cubic feet per minute. A lower flow rate can provide quieter operation and may be suitable for some applications. In order to keep the temperature more even throughout the Environmental Chamber, however, a higher flow rate setting is generally recommended. A higher fan speed setting will generate more air flow within the environmental chamber so that the temperature in the chamber remains more uniform.



**Important** It is recommended that, for normal use, the Fan Control Knob is set to the middle of the full range of the knob's rotation and that you wait approximately 3 hours for the Environmental Chamber to stabilize before beginning any imaging tasks.



**WARNING! Avoid blocking the airflow.** Although a built-in thermal cutoff switch in the temperature controller is designed to reduce the hazard, a fan failure or obstruction in the airflow has the potential for overheating the system and damaging the DeltaVision system or even causing a fire.

### CO<sub>2</sub> Humidifier

When filled with pre-warmed water, the CO<sub>2</sub> Humidifier contains enough water to last for seven days of continuous use. The CO<sub>2</sub> Humidifier can be cleaned with any of the following: lab soap (such as Alconox), 70% Ethanol, or 10% bleach.

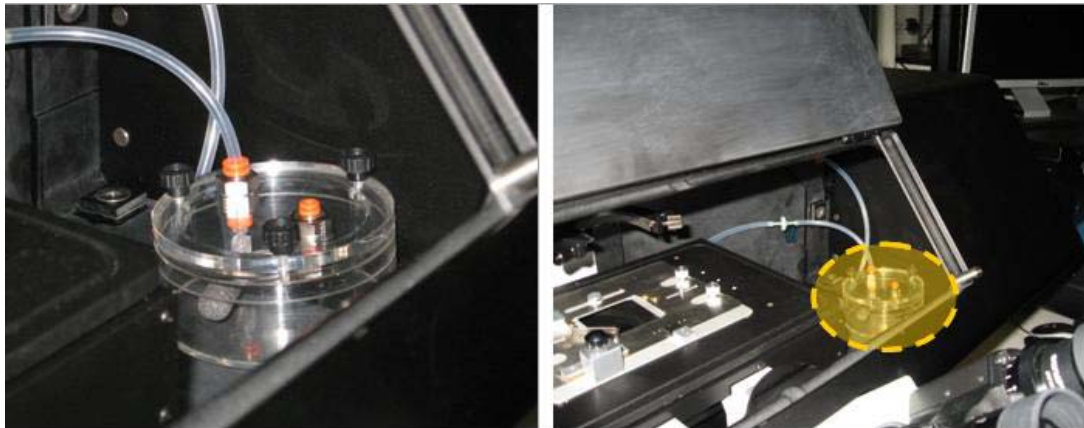

### Flowmeter

The Flowmeter for the Environmental Chamber controls the flow of the air/CO<sub>2</sub> mixture in and out of the chamber. Users will need to provide premixed air cylinders for the Environmental Chamber. The Flowmeter provides a flow range from 1.3 ml/min to 5.8 ml/min. The Flowmeter should be set so that bubbles are slowly emerging from the stone, similar to the bubbles in carbonated soda.



**CAUTION!** The maximum inlet pressure for the Flowmeter is 100 KPA (14.5 PSI).

### CO<sub>2</sub> Chamber

The CO<sub>2</sub> Chamber fits directly over the sample area and provides CO<sub>2</sub> to the sample during imaging. Place the chamber over the sample before imaging.

The CO<sub>2</sub> Chamber is not attached in any way to the DeltaVision stage however, proper orientation of the CO<sub>2</sub> Chamber is essential for successful imaging. The CO<sub>2</sub> input tube



should be on the right side (as shown below) and the chamber should be flush with the silver block on the left side.

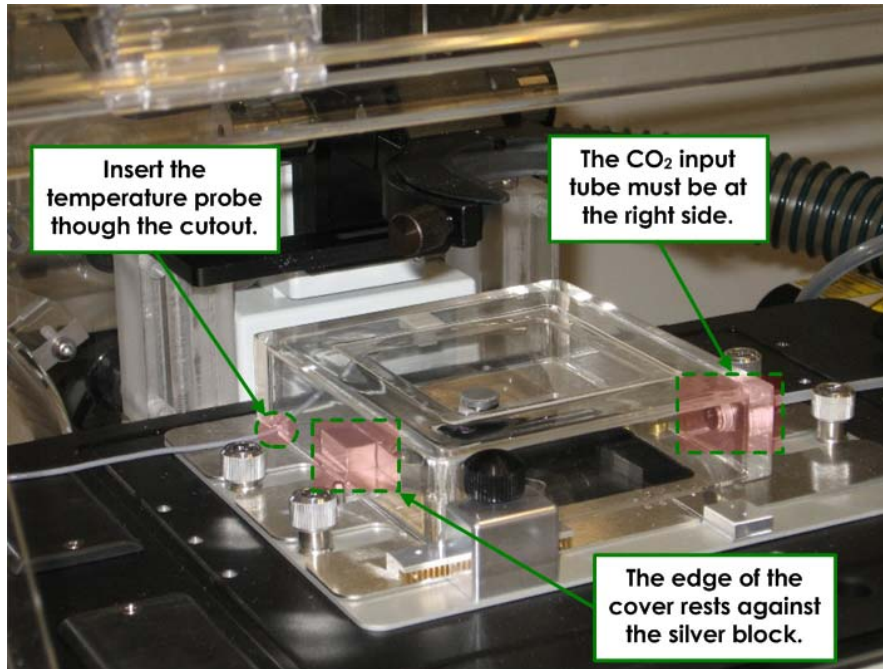

CO<sub>2</sub> Chamber - Positioning

When you use the CO<sub>2</sub> Chamber, the temperature probe must be relocated from its stand near the transmitted light tower and inserted through the cutout on the left side of the chamber as shown.

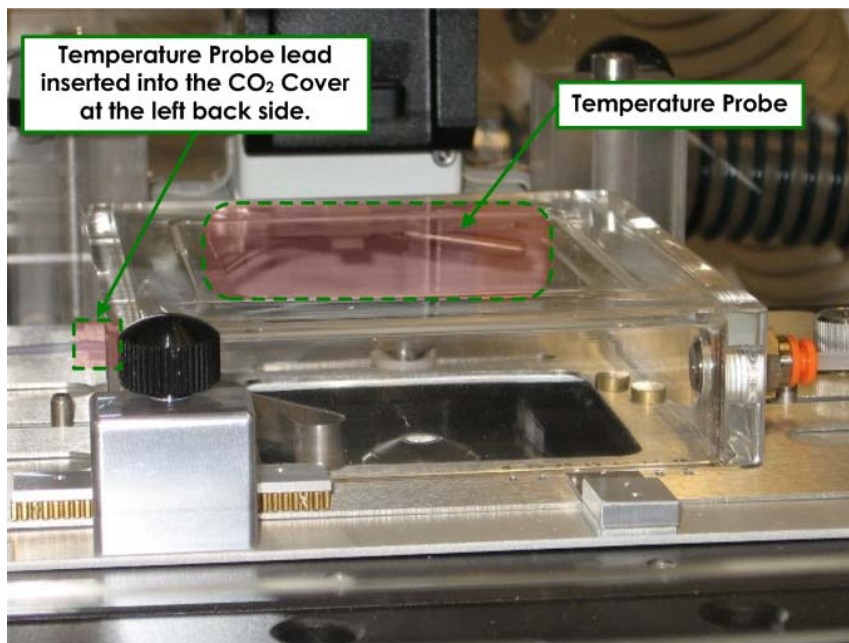

CO<sub>2</sub> Chamber - Temperature Probe



**Note** Using the CO<sub>2</sub> chamber limits the use of the Repeatable Slide Holder. With the CO<sub>2</sub> chamber installed, some of the detent positions are not available.

---

The CO<sub>2</sub> chamber for the Microtiter Stage (see next section) is larger to accommodate a microtiter plate, but otherwise is set up using the same method as the standard CO<sub>2</sub> chamber.

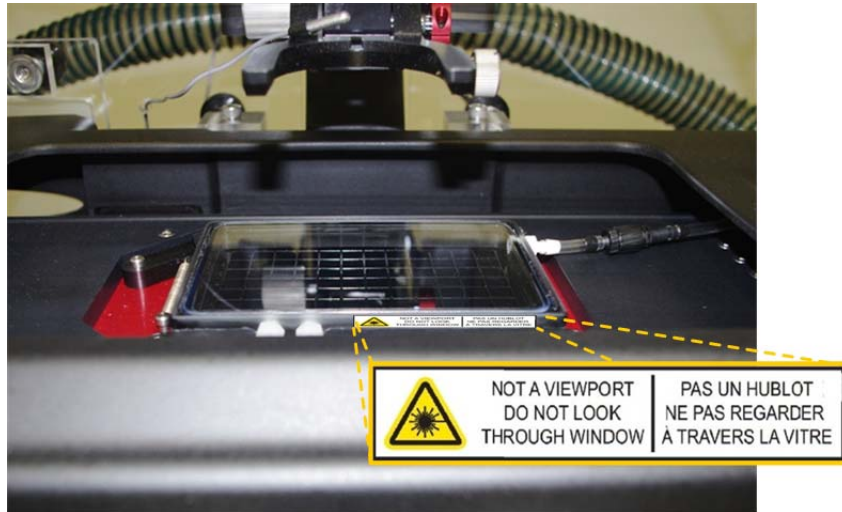

Microtiter Stage CO<sub>2</sub> Chamber and TIRF Cover



**WARNING!** DO NOT use the system for TIRF imaging without this cover in place.

---

### Air Filter

The Environmental Control System is equipped with an intake air filter. This filter is removable and cleanable. You are advised to clean this filter every six months.



Heater Filter Housing

**To remove and clean the air filter:**

1. Turn off the heater.
2. The filter can be removed from the filter box without removing the filter box from the heater. If desired, remove the filter box by pulling it away from the heater. Magnets hold the filter box in place.

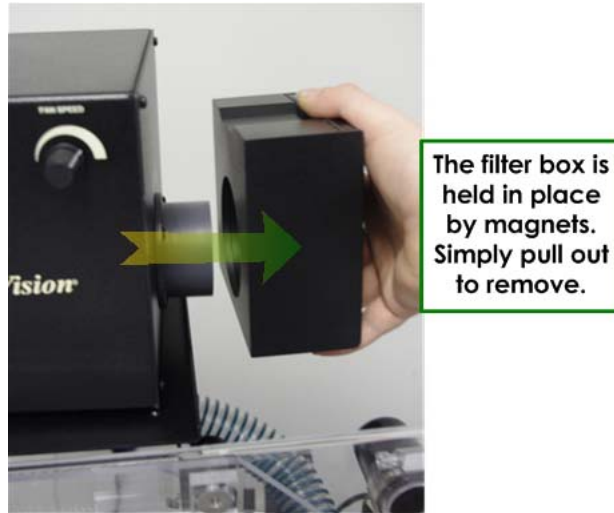
**Removing the Filter Housing**

3. Slide the filter out of the filter box as shown below.

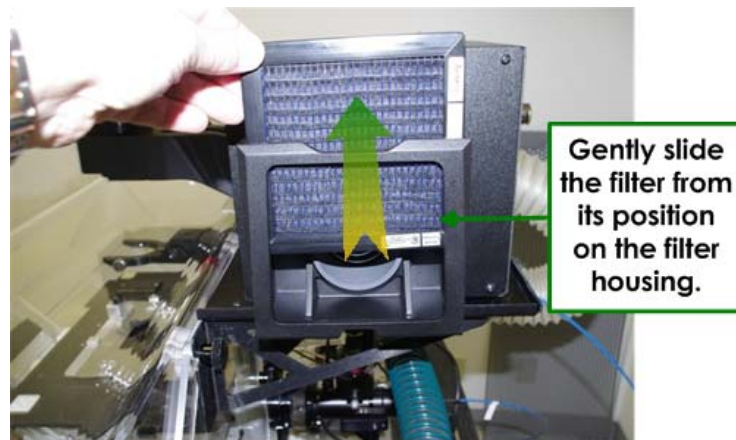
**Removing the Filter**

4. Using a vacuum cleaner, thoroughly clean the filter mesh.
5. Reinstall the filter and box in reverse order of removal.
6. Continue with normal operation of the system.

**The Microtiter Stage Option**

The addition of a Microtiter stage to a DeltaVision system enhances the imaging system's capability by providing the ability to scan microtiter plates. With a Microtiter stage on a

DeltaVision system, you can design a plate scan by generating a point list that corresponds to the nominal center point of each well of interest, and then defining how the wells are to be sampled.

The model used for sampling plates is a matrix of N rows by M columns of *panels*. Each panel can be a Z stack, a single Z, or an *OAI* (optical axis integration) scan. The panels can be separated by spacing defined through the software. You can specify autofocus for each individual well, or for every panel/stack within the matrix. You can also set up parameters to specify the autofocus sampling range that represents the well-to-well and panel-to-panel variability of the focal plane.



**Microtiter Stage for DeltaVision Systems**

For instructions on basic operation of the Microtiter Stage option, refer to “Using the Microtiter Stage Option” on Page 7.18.

### **Additional Filter Modules**

You can purchase additional DeltaVision filter modules and use them to quickly change the filter sets to meet different imaging requirements.

You can purchase a Live Cell Filter Module that is pre-loaded with four filter sets that are commonly used for live cell imaging. You can also purchase empty filter modules and insert customized filter sets into those modules.

### **TIRF/PK Module**

The TIRF/PK Module provides the ability to add a laser beam into the optical path of the DeltaVision microscope. A laser beam is introduced into the back aperture of the microscope objective to provide a focused illumination spot in the center of the optical field. With lasers attached (like the DeltaVision X4 Laser Module), users can design photokinetic experiments and TIRF (Total Internal Reflective Fluorescence) experiments. TIRF is an imaging method that offsets the laser excitation light slightly off-axis using a special TIRF-based objective. The excitation light emits from the objective at a shallow

angle, enters into the cover slip, and bounces inside the cover slip creating an evanescent field of fluorescence. The TIRF/PK Module is optional for the DeltaVision system and is offered in three varieties: TIRF/PK, TIRF only, and PK only.

## X4 Laser Module

The X4 Laser Module houses up to four lasers. The lasers are enclosed in a rack-mounted module that fits in the cabinet. All lasers in the X4 Laser Module are active at the same time and controlled with electronic shuttering. Light is directed from the lasers to the light path through the TIRF/PK module that mounts on the back of the Fiber Optic module.

If your system has the X4 Laser module, you can use *softWoRx* to run Photokinetic laser-based experiments and/or TIRF (Total Internal Reflection Fluorescence) experiments.

### Laser Safety using the X4 Laser Module

The laser interlock is attached to the port selector knob on the front of the microscope. When the port selector is set to the eyepieces, the laser shutters are prohibited from opening. Only when the port selector knob is set to the Camera port will the laser shutters open.

For complete information on laser safety and proper labeling for the X4 Module, refer to *Appendix F, Lasers and Safety Issues*.

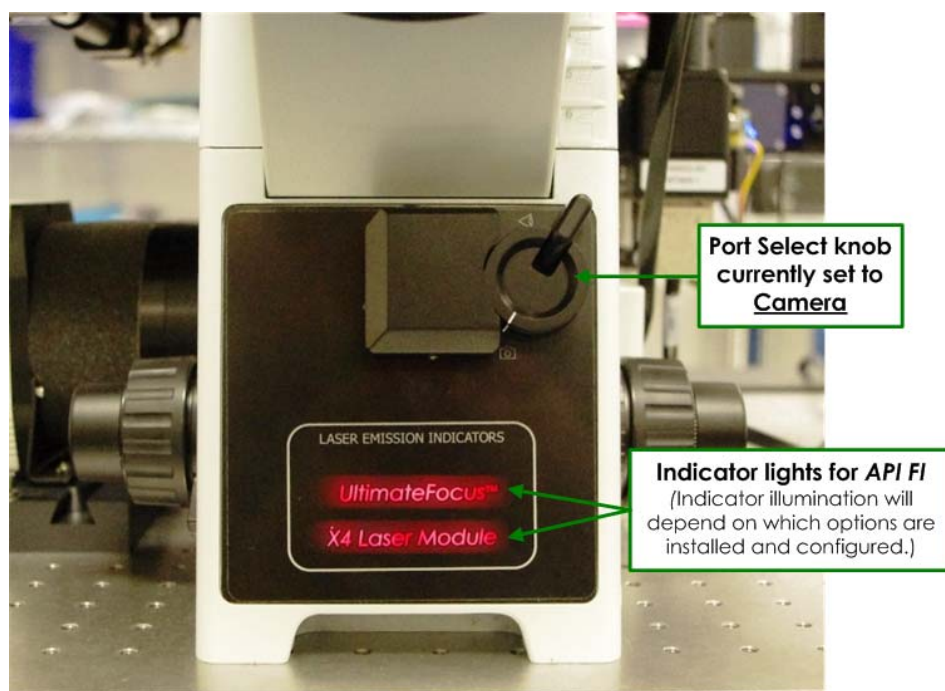

The port selector knob and the UltimateFocus and X4 Laser Module indicator lights are shown on the front of the DeltaVision microscope.

For more information on the X4 Laser Module and the TIRF technique, see *X4 Laser Module and TIRF*.

## Using the X4 Laser Module

The X4 Laser Module can contain up to four lasers. All of these lasers can be active at the same time to allow for extremely fast sequential activity. When using any or all of these lasers, your first task should be to check their status.

You can view and adjust the status of all available lasers from the Resolve3D Settings window, in the **Lasers** tab. The lasers are displayed with one of four levels of status:

- **Off** – The laser is not in use and is in rest mode. The laser may enter rest mode if it has not been used for a specified period of time. In this mode, laser lifetime is preserved.
- **Warming Up** - The X4 Module has recently been started and the laser electronics are warming up prior to allowing access for control. This period is 60 seconds from when the laser electronics was enabled during initialization.
- **Stabilizing** – The laser is adjusting to a new requested power setting. The length of time for a laser to stabilize after a new power request varies between 3 and 15 seconds depending on the laser model.
- **Ready** – The laser is now available for use.
- **Locked** – The laser interlocks are open, prohibiting all laser function (for example, the eyepiece port is selected).

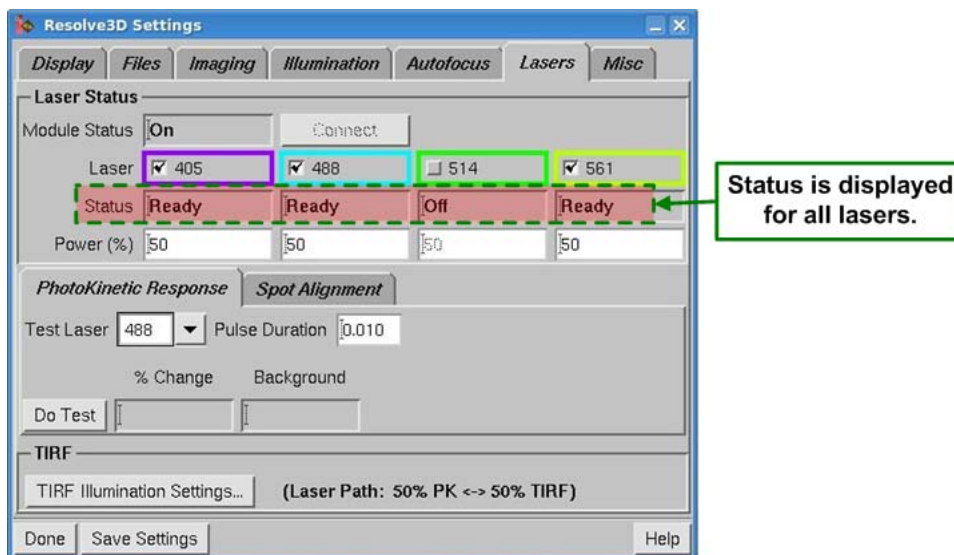

Resolve3D Settings Window | Lasers tab showing status for all four lasers

### Activating a Laser:

- Click the check box next to the specific laser to enable/disable emission.

### Setting Laser Power:

- Laser power is displayed as a percentage of the full power of each laser. Adjust the laser's power by entering a numerical value.

## X4 Laser Module and TIRF

With the X4 Laser module, you can use *softWoRx* to run Photokinetic laser-based experiments or TIRF experiments. The module houses up to four lasers and all lasers can be active at the same time and controlled by electronic shuttering.

TIRF is an optical sectioning technique that limits fluorescence imaging to a thin area at the surface of a specimen, typically restricted to a depth of only 100 – 200nm, resulting in an enhanced signal-to-noise ratio and increased imaging contrast.

This technique uses a simple law of physics to improve biological imaging. When light passes from a medium of high refractive index to a medium of low refractive index and the angle of incidence is greater than or equal to the critical angle, the light will reflect off of the interface and not actually enter the second medium. Under these conditions, an electromagnetic wave traveling perpendicular to the interface is created. This electromagnetic wave has the same wavelength as the light that created it and decays very rapidly in the direction of the optical axis such that most of the energy is lost within a couple of hundred nanometers of the interface. This electromagnetic wave is known as an *evanescent wave*.

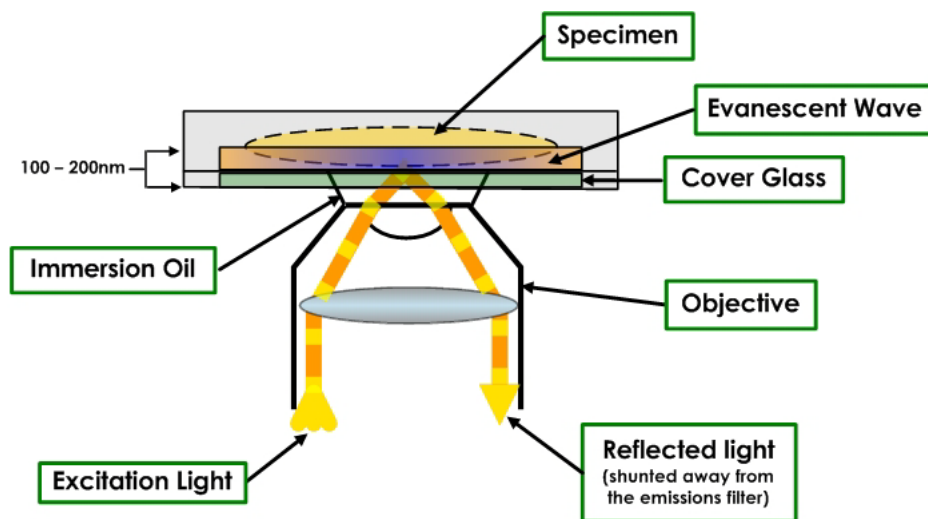

If there are fluorescent molecules in close proximity to the interface, and these molecules are capable of absorbing the wavelength of the evanescent wave, then these molecules (known as *fluorophores*) will become excited and fluoresce. Since the evanescent wave decays rapidly, molecules that are more than about 200nm from the surface of the interface will not be sufficiently excited to fluoresce. These molecules contribute to neither the signal nor the background (noise) fluorescence.

For TIRF slides, the sample must be grown on a glass cover slip and the sample is bathed in a water-based buffer with a refractive index of approximately 1.33. The glass cover slip typically has a refractive index of about 1.518. When light is introduced from the cover slip to the buffer at an angle that is greater than about  $61^\circ$ , the light reflects off the glass-water interface and establishes an evanescent wave that will travel into the buffer.

Fluorophores close enough to the interface and that can be excited by the evanescent wave will generate fluorescence that is then detected through the objective lens.

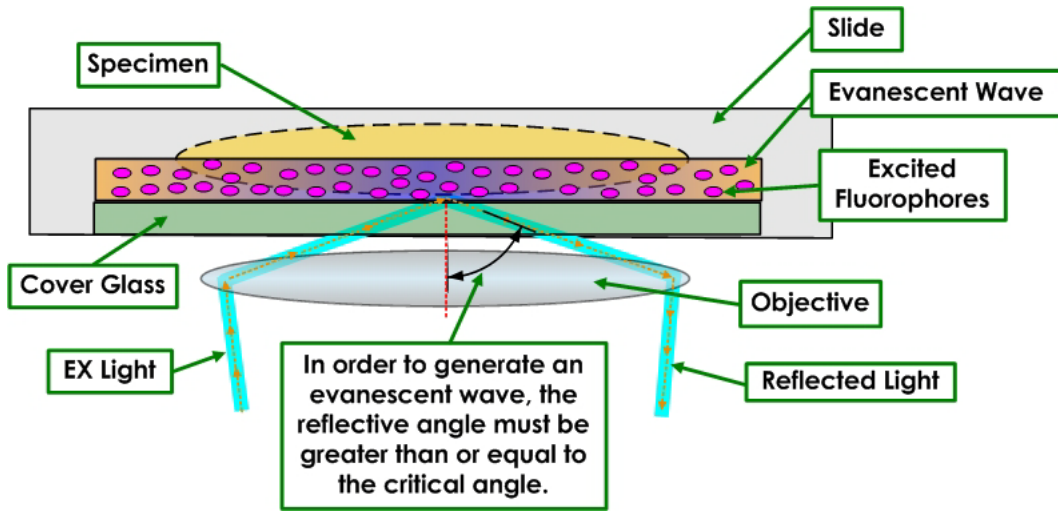

## TIRF-specific Laser Safety Considerations

Due to the TIRF illumination optics, the light being emitted from the DeltaVision objective is collimated and has high power density. The TIRF system also has the ability to direct this light to sharp off-axis angles relative to the objective axis.



**WARNING!** When using the TIRF system, use extreme caution that the emitted light is not directed into the user's eyes. Appropriate laser safety goggles selected for the specific wavelength activated are mandatory.



**WARNING!** DO NOT use the system for TIRF imaging without the TIRF Cover in place.

## Imaging Using TIRF

To generate a TIRF image:

1. Locate the sample through the eyepieces using widefield fluorescence.



- From the Resolve3D Settings window under the **Lasers** tab, click the **TIRF Illumination Settings** button near the bottom of the window.

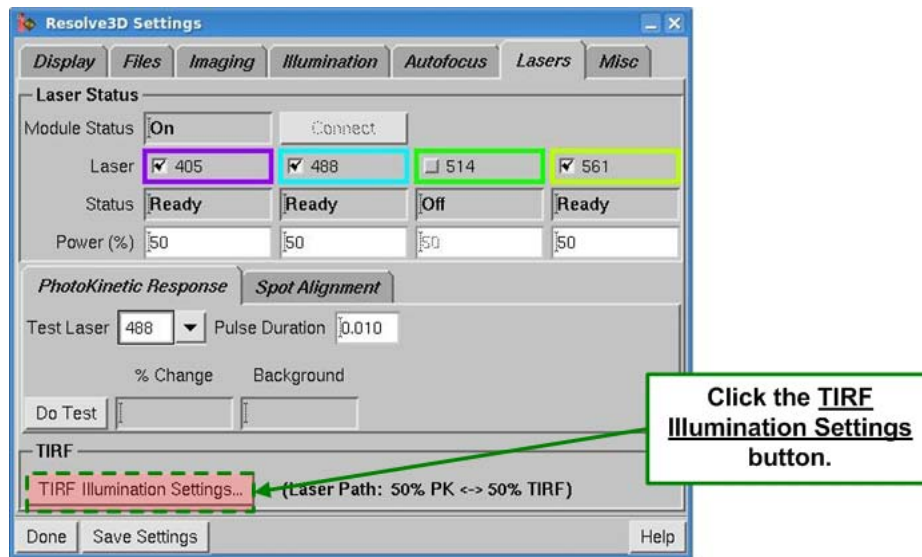

The TIRF Illumination Settings window is displayed.

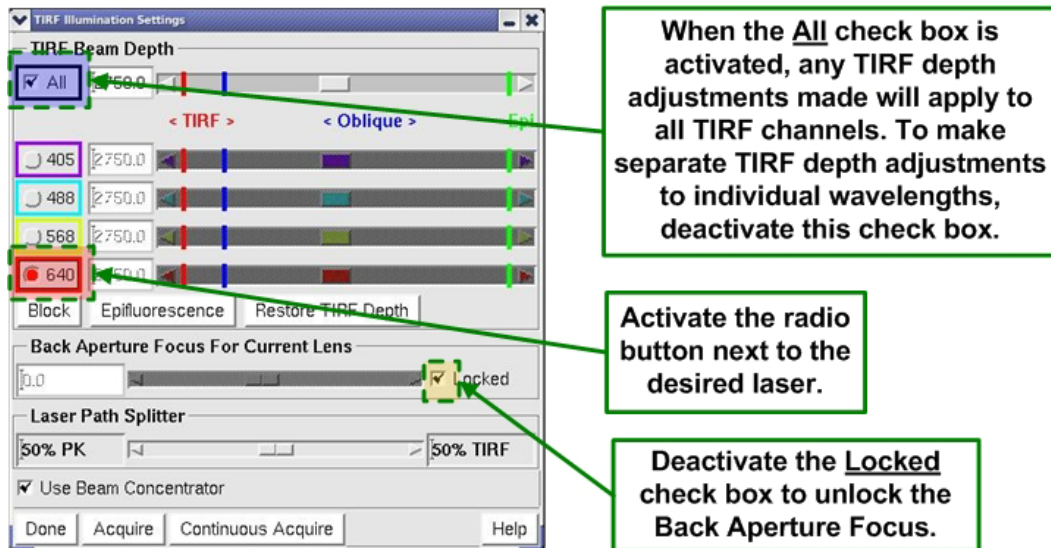

- Activate the radio button next to the laser you want to adjust.
- (Advanced only – not required): Deactivate the **All** check box to make unique angle adjustments for each wavelength (channel).
- (Advanced only – not required): In the **Back Aperture Focus For Current Lens** field, deactivate the **Locked** check box to release the slider tool for use. By default, this check box is activated (slider is locked).
- From the Resolve3D main menu, use the **Acquire** button with the Z control to adjust the focal plane.

When you control the incident angle of illumination, an evanescent field is generated. Adjusting the angle changes the depth of light penetration into the sample.

You can adjust all laser angles together, or you can adjust them separately when you activate the **Adjust channels independently** check box.

7. Adjust the TIRF angle as follows:
  - **Coarse adjustments** are made to the TIRF angle by dragging and dropping the box in the slider bar using the left mouse button. An image is acquired when the mouse button is released.
  - **Fine adjustments** are made to the TIRF angle by clicking the arrows on either end of the slider bar or by using the left or right arrows on the workstation keyboard.
8. To illuminate the sample and not generate an evanescent wave, click the **Epifluorescence** button.
9. To return the laser to that last incident angle used, click the **Restore TIRF Depth** button.
10. Adjust the slider for the **Laser Path Splitter** to determine the amount of light to send to the TIRF light path.

The screenshot shows the 'TIRF Illumination Settings' dialog box. It features several sections:
 

- TIRF Beam Depth:** A list of channels (All, 405, 488, 568, 640) with sliders for each. The 'All' channel is selected. Below the sliders are buttons for 'Block', 'Epifluorescence', and 'Restore TIRF Depth'.
- Back Aperture Focus For Current Lens:** A slider set to 0.0 with a 'Locked' checkbox.
- Laser Path Splitter:** A slider between '50% PK' and '50% TIRF'.
- Use Beam Concentrator:** A checked checkbox.
- Buttons at the bottom: 'Done', 'Acquire', 'Continuous Acquire', and 'Help'.

 Three callout boxes with green borders and arrows point to specific controls:
 

- The top callout points to the 'Epifluorescence' button, stating: 'Click the **Epifluorescence** button to illuminate the sample and not generate an evanescent wave.'
- The middle callout points to the 'Restore TIRF Depth' button, stating: 'Click the **Restore TIRF Depth** button to return the laser to the last incident angle used.'
- The bottom callout points to the 'Laser Path Splitter' slider, stating: 'Adjust the **Laser Path Splitter** slider to indicate how much light should go to the TIRF light path.'

## Photokinetic (PK) Experiments

A template within softWoRx, in the Resolve3D Design/Run Experiment window contains basic photokinetic experiments such as FRAP (fluorescence recovery after photobleaching).

### To run a basic PK experiment:

1. Click the **Experiment** button in the Resolve3D main menu to open the Design/Run Experiment window.
2. Select the **Design** tab, then select the **PhotoKinetics** tab.

- On the **Laser Events** tab, select the desired laser from the drop-down menu.

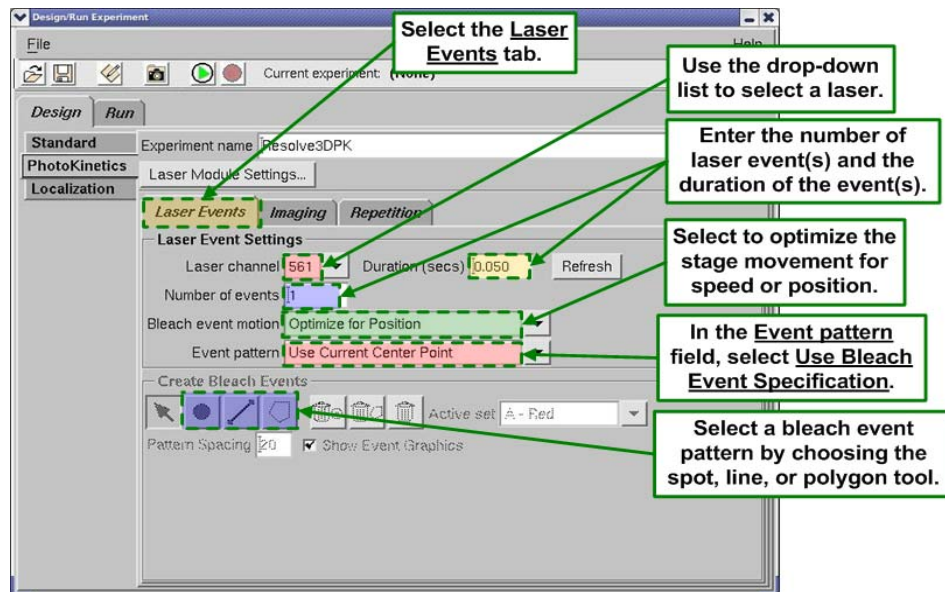

- To generate multiple bleach events, the stage moves the sample to the site of laser activity. You can optimize this motion for either speed or position. When **Optimize for Position** is selected, the stage goes through an LMC (Lost Motion Compensation) move to achieve the most accurate position. This move takes more time than when **Optimize for Speed** is selected.
- Bleach events occur at either the center point of the field of view or in a specified position. Select **Use Bleach Event Specification** in the **Event pattern** field.
- In the Create Bleach Events section of the window, select an event pattern by choosing the spot, line, or polygon tool.
- Click on the image in the Data Collection window to generate the selected bleach pattern.
- Click on the **Imaging** tab to select the **Channel Setup** (exposure time, wavelength, and illumination source settings) and **Time Course Specification** conditions.

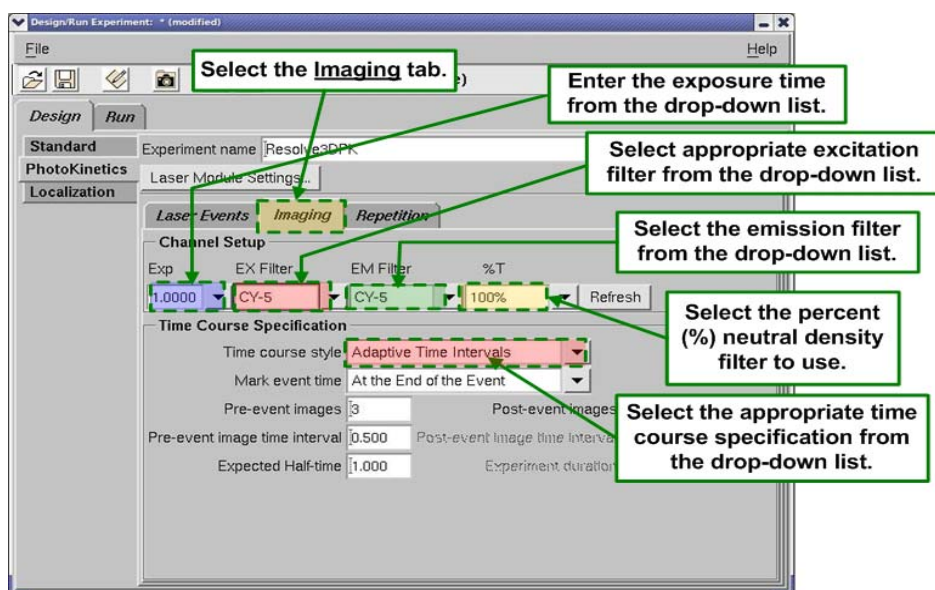

9. When you select the **Time course style**, the drop-down list presents three choices:
- **Adaptive Time Intervals** – allows you to select the total number of images to be collected. Images are collected faster after the bleach event and then slower over time.
  - **Uniform Time Intervals** – allows you to select the total number of images collected, as well as the time interval between images. The value in the **Experiment Duration** field is calculated based on these factors. Also, if you change the value in the **Experiment Duration** field, the **Post-event images** field automatically updates.
  - **As Fast As Possible** – collects the images in rapid succession with no time-lapse interval. For this style, you enter only the total number of **Post-event images**.

## The UltimateFocus Module

After the operator has found the proper focus and marked a point of interest, the UltimateFocus Module maintains focus using hardware methods for that point during the experiment when enabled. The UltimateFocus Module uses an infrared laser that follows the illumination path and bounces off the cover slip/sample interface. The reflected beam is evaluated and the software returns an offset to the Z motor for automatic stage adjustment to maintain focus. The UltimateFocus Module is optional for a DeltaVision system. For more information on the UltimateFocus Module, see “Using UltimateFocus” on Page 7.39. For complete information on laser safety and proper labeling for the UltimateFocus Module, refer to *Appendix F, Lasers and Safety Issues*.

## Analysis Workstations

You can purchase additional *softWoRx* Linux analysis workstations.

The *softWoRx* Linux workstation includes all of the *softWoRx* Analysis modules, including 3D Visualization tools, Colocalization, Fluorescence Resonance Energy Transfer (FRET)

Analysis, Fluorescence Recovery After Photo-bleaching (FRAP) Analysis, Intensity and Distance Measurement, and Modeling.

## Software

### softWoRx Explorer

softWoRx Explorer is a cross-platform image viewer that is available for many commonly used operating systems.

softWoRx Explorer allows you to view and explore DeltaVision images and images from other sources that contain spatial, temporal, and spectral ranges. In addition to displaying data in the X and Y plane, you can scroll through Z sections and time-lapse data. Individual spectra (i.e., channels or fluorescent wavelengths) can be hidden or displayed in a variety of colors.

### softWoRx Suite for Windows Option

softWoRx Suite is a Windows-based ensemble of software. It provides sophisticated multi-dimensional data visualization, analysis, image restoration, image correction, and image viewing management, all within an easy-to-use streamlined browser interface.

### softWoRx Suite Advanced Option

The Advanced Option for softWoRx Suite includes two sophisticated analysis features: *4-D Particle Tracking* and *ImarisColoc*. softWoRx Suite Advanced Option is offered by GE in collaboration with Bitplane, AG.

*4-D Particle Tracking* allows users to observe temporal changes of objects. This tracking module offers a choice of methods for both detection and tracking and allows analysis and measurement of various object properties.

The Colocalization feature enables users to easily isolate, visualize, and quantify regional overlap in 3D and 4D images. Results can be presented in two ways—as a new 3D or 4D channel or as a statistical report.

### softWoRx DMS

softWoRx DMS (Data Management Solution) provides a functional infrastructure for the storage of biological images and their associated metadata in a centralized database. Like softWoRx Suite, softWoRx DMS includes the Browser and the Explorer programs, but unlike softWoRx Suite does not have the ability to perform any type of image processing. The DMS product actually has two distinctive parts. One part is a *DMS Server* and the other part is represented by the *DMS clients*.

A DMS Server is made up of a specific configuration of the centralized database. The DMS clients are the different programs and methodologies of accessing the image data within the centralized database (ie. softWoRx, softWoRx Suite, and softWoRx DMS).

## Differential Interference Contrast (DIC) Module

Differential Interference Contrast (DIC) microscopy is a method for imaging unstained live or fixed specimens that may appear nearly invisible with conventional brightfield microscopy. The resulting image looks as if the specimen is casting a shadow to one side.



The shadow primarily represents a difference in the refractive index and thickness of the specimen rather than its topology. With this method of imaging, a DIC prism (known as a Wollaston Prism) splits an incident beam of plane-polarized light so that one part of the beam passes through one region of the specimen and the other passes through a closely adjacent region. A second prism then reassembles the two beams. Minute differences in the thickness or in the refractive indices between adjacent parts of a sample are converted into bright regions (if the two beams are in phase when they recombine) and dark regions (if they are out of phase).



**DIC Image Samples**

DIC microscopy has proven to be a very important technique for observing even very small objects, such as single microtubules (after digital enhancement) or acquiring useful reference images in combination with fluorescence images from the same focal plane.

### DIC Optics

The arrangement of the four essential DIC optics in the order of their location in the optical pathway from the transmitted light source to the image plane include:

- A polarizer in front of the condenser to produce a plane polarized light source.
- A condenser DIC prism mounted close to the front aperture of the condenser to act as a beam splitter.
- An objective DIC prism mounted close to the back aperture of the objective lens to recombine the two beams in the objective back aperture.
- An analyzer to “analyze” rays of plane and elliptically polarized light coming from the objective and to transmit plane polarized light that is able to interfere and generate an image in the image plane.

The following illustration shows the basic layout for DIC.

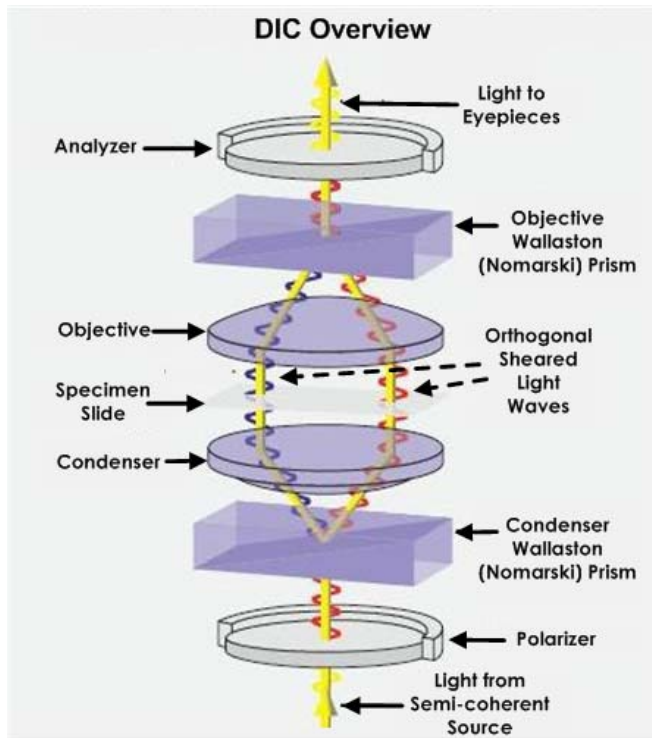

## Installing the DIC Module

The DIC module is installed into the yoke on the DeltaVision system's transmitted light pillar.

**To install a DIC module on a DeltaVision system:**

1. Align the pin on the back of the DIC condenser with the slot on the inside of the yoke.

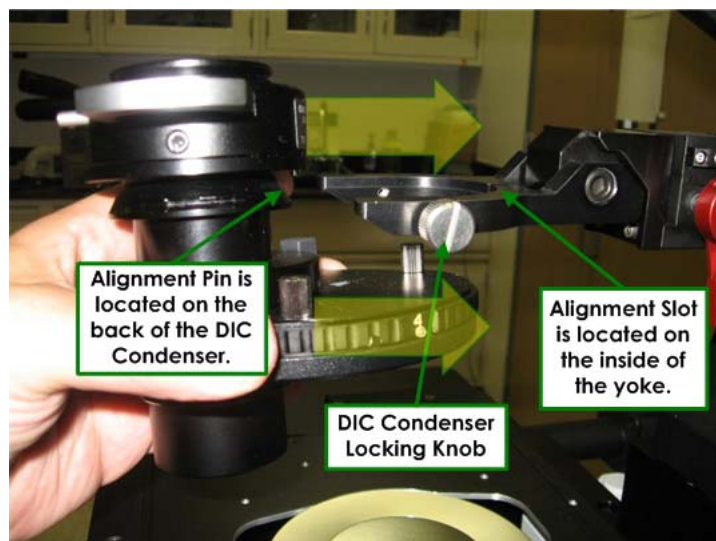

2. Tighten the locking knob on the right to fix the condenser in place.

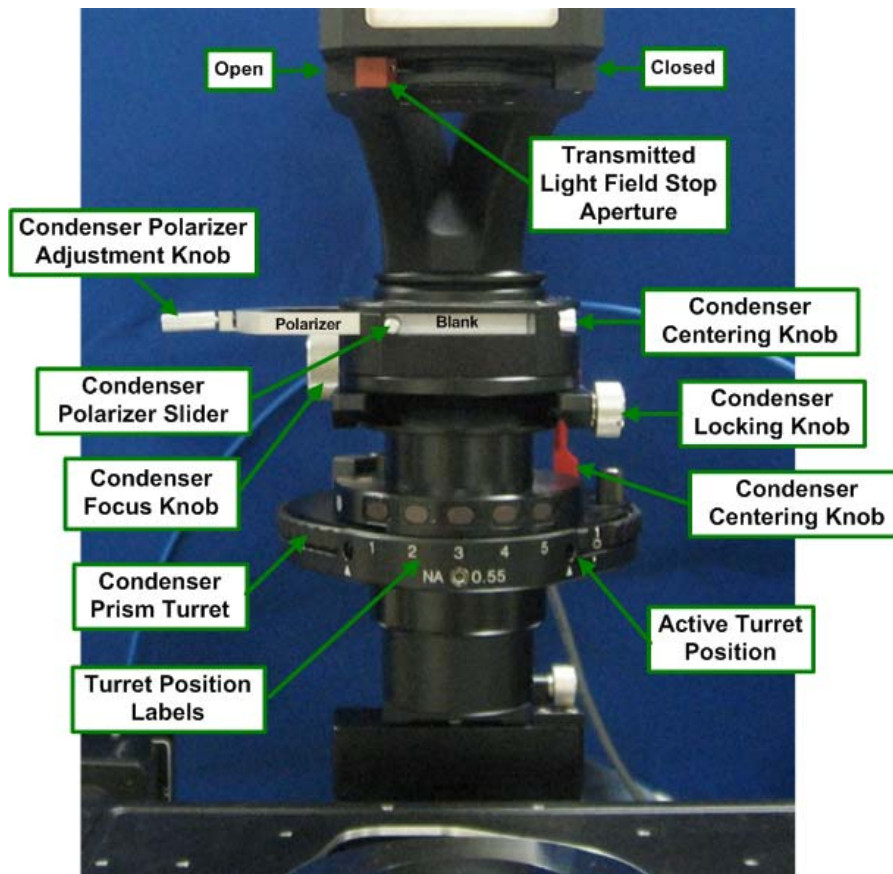

Overview of DIC Controls

### Aligning the DIC Module

To acquire successful DIC images, it is necessary to properly align all of the DIC components. The alignment process includes setting up Köhler Illumination for the transmitted light source as well as crossing (aligning to 90 degrees) the Condenser Polarizer with both the Emission Polarizer and Eyepiece Polarizer. The Condenser Polarizer is left stationary and the other two polarizers are oriented according to the Condenser Polarizer's position. To accomplish this, you will first remove the Eyepiece Polarizer and use it to find the proper position for the Emission Polarizer. When satisfied with the position of the Emission Polarizer in relation to the Condenser Polarizer, you then replace and cross the Eyepiece Polarizer with the Condenser Polarizer.



**To set up Köhler Illumination:**

1. Move the Condenser Polarizer slider to the Blank position, as shown.

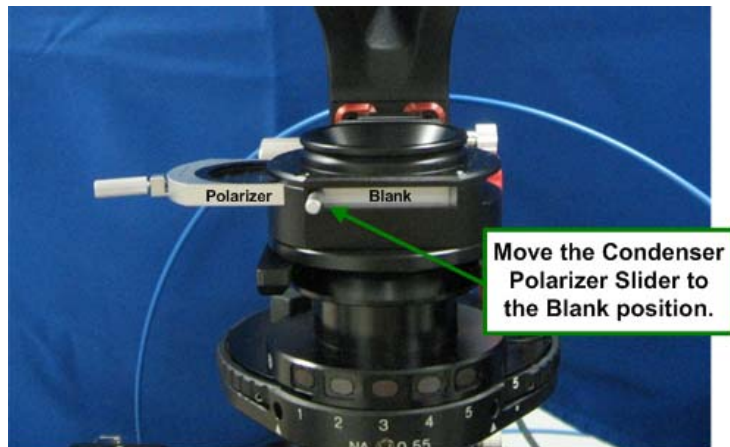

2. Rotate the Condenser Prism Turret to a blank position.

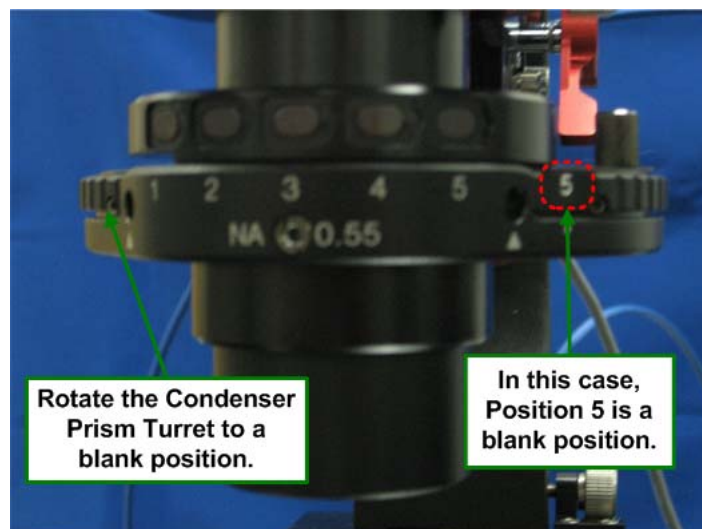

3. From beneath the right underside of the microscope stage, remove the Principal Prism Slider from the light path, as shown.



Removing the Principal Prism Slider from the Light Path



**Note** It is not necessary to completely remove the Principal Prism Slider from the system. The slider clicks into place in both the In and Out positions.

4. Using the smallest magnification objective available, mount a specimen slide and focus on the specimen using either brightfield or fluorescence.



**Note** With higher magnification objectives, 60x or greater, it may be difficult to see the edges of the Transmitted Light Field Stop Aperture.

5. Move the Transmitted Light Field Stop Aperture to the Closed position.

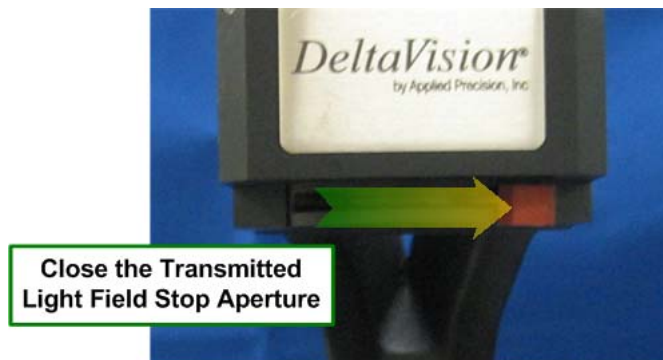

6. Use the DeltaVision keypad to open the Transmitted Light Shutter.
7. Observe the specimen through the oculars while turning the Condenser Focus Knob. You will see the Transmitted Light Field Stop Aperture encroaching on the image as you get close to the focal point. Keep focusing the Condenser until the edges of the Transmitted Light Field Stop Aperture (the blades of the iris) are in sharp focus.



**Note** If you lose light as you approach the focal point, you'll probably need to re-center the condenser until the entire field becomes bright, and then continue focusing.

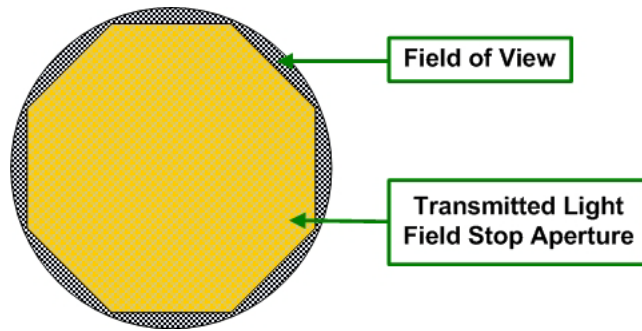

If you cannot see the entire iris while moving the Condenser Focus Knob, it may be necessary to alter the centering before you are able to focus on the edges of the iris.

- Center the Transmitted Light Field Stop Aperture within the field of view using the two Condenser Centering Knobs.
  - Repeat this step as necessary to achieve optimum focus and alignment.
8. After the DIC Condenser has been focused and centered, move the Transmitted Light Field Stop Aperture toward the Open position until the aperture is just out of view.

The DIC Module will remain in Köhler alignment when different objectives are used, however, you'll need to adjust the Transmitted Light Field Stop Aperture (opened or closed to keep the aperture just outside of the field of view) for each different magnification. Also, focus can change when moving the DIC condenser so it's important to check Köhler illumination frequently.

#### Before you proceed to crossing polarizers:

If you are able to verify *maximum extinction* as follows, you may not need to perform the procedure for crossing the Emission Polarizer with the Condenser Polarizer:

- Verify that both the Condenser Polarizer and the Emission Polarizer are in the light path.
- Acquire an image. Adjust Exposure Time and %T to obtain maximum intensity between 500 and 1500 counts.
- Acquire images continuously (**File |Continuous Acquire**) as you slowly move the Condenser Polarizer Adjustment knob until the lowest maximum intensity is reached. This point is maximum extinction. This point should be close to the center of the knob's travel, with the maximum intensity increasing on either side.



**Note** If a minimum intensity (maximum extinction) cannot be found, the orientation of the Emission Filter Wheel must be adjusted as described in the following procedures.

---

- If you are able to attain maximum extinction, tighten the Condenser Polarizer Adjustment knob to lock the polarizer in place at that position. If this is the case, you will not need to cross the Emission and Condenser Polarizers. Skip the following section and continue with the procedure for crossing the Eyepiece Polarizer with the Condenser Polarizer.

**To cross the Emission Polarizer with the Condenser Polarizer:**

1. Remove any specimens from the stage and clean the objective.
2. Set the Eyepiece and Emission filter wheels to the Polarizer position.
3. Remove the Eyepiece Polarizer from the Eyepiece filter wheel. (See "Changing Filter Wheel Modules" on Page 9.4 for illustrated details on removing the Eyepiece assembly.)
  - Support the white Eyepiece assembly and use a 3mm hex key to remove the Eyepiece assembly from the Eyepiece Filter Wheel. Set the Eyepiece assembly aside. Leave the Eyepiece Filter Wheel attached to the microscope base.

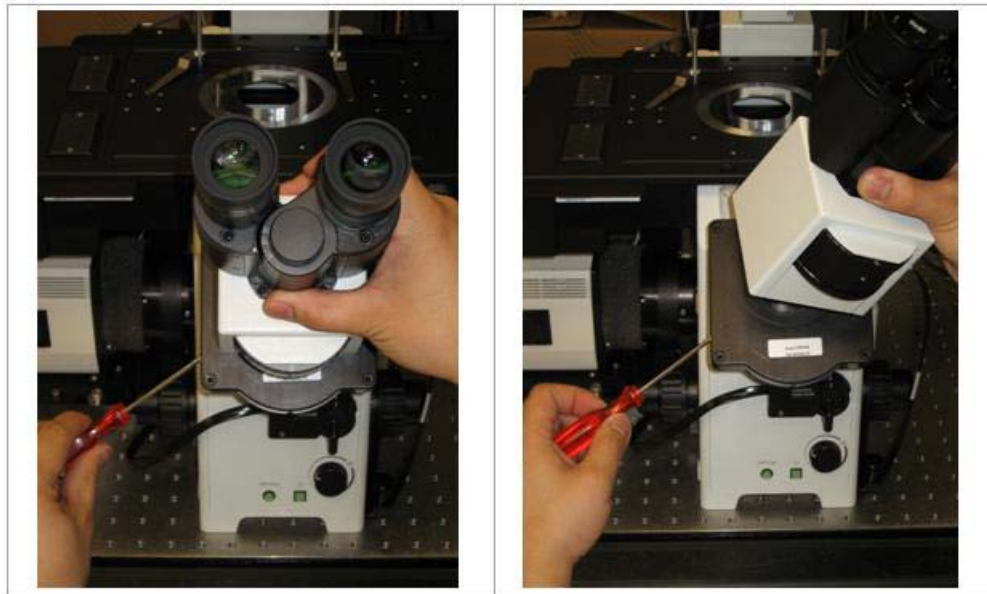

**Removing the Eyepiece**

- Carefully remove the Polarizer from the Eyepiece Filter Wheel and set it aside. Be careful not to touch the surface of the filter.

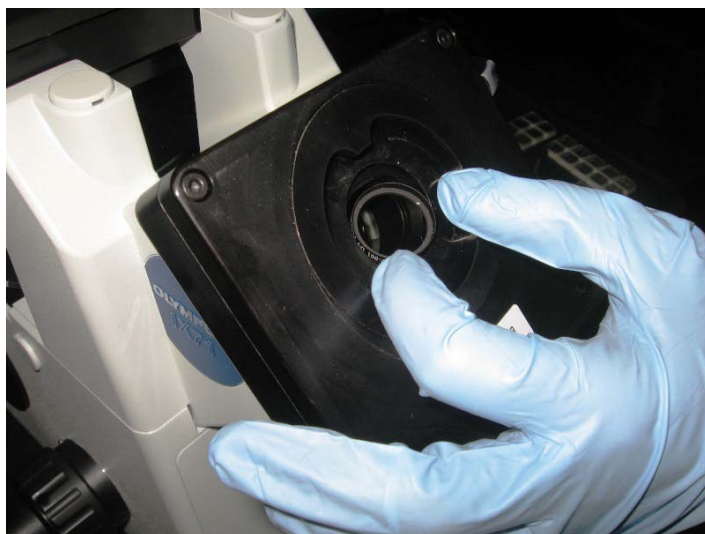

**Removing the Polarizer from the Eyepiece Filter Wheel**

- Leave the white Eyepiece assembly off for now.
4. To gain access to the Emission Filter Wheel, remove the camera by pushing in and pulling up on the camera end as shown. Refer to “Changing Cameras” on Page 9.1 for removal details.

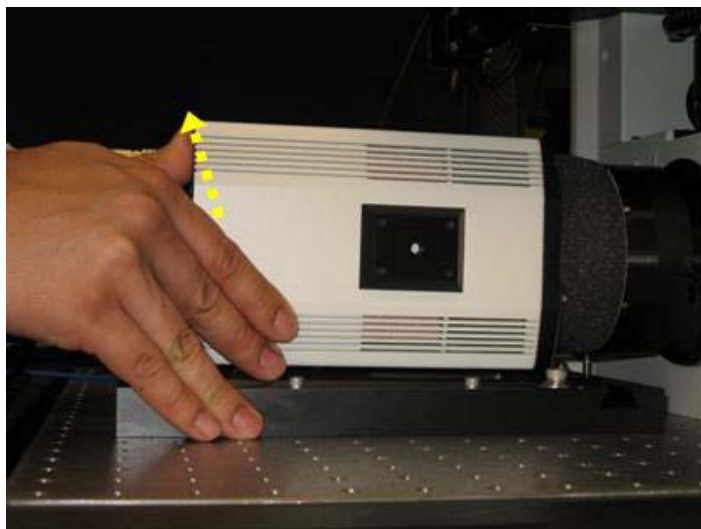

**Removing the Camera**

5. Using a 3mm hex key, loosen the set screw to remove the Emission Filter Wheel assembly.



**Note** Leave the Emission Filter Wheel Motor Cable connected, but use care not to strain this connection.

---

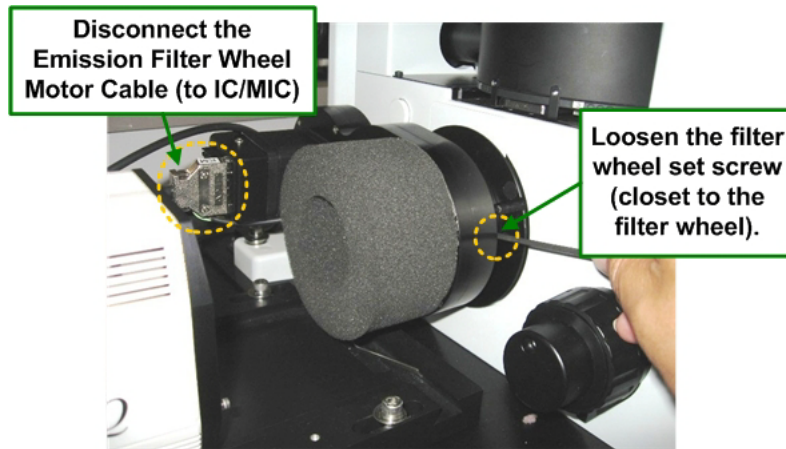

Removing the Emission Filter Wheel

6. Using the Condenser Polarizer Slider, move the Condenser Polarizer into the light path. Move the Condenser Polarizer Adjustment Knob into the center of its travel and tighten the knob to secure it.

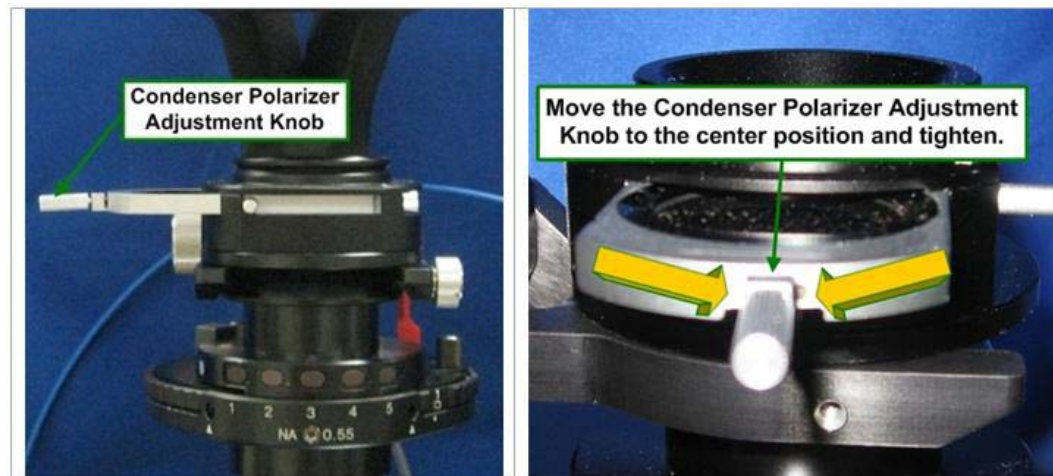

7. Verify that the Condenser Prism Turret is in a blank position and that the Principal Prism Slider is not in the light path.

8. Switch the Port Selector on the microscope to the **Camera**  icon.

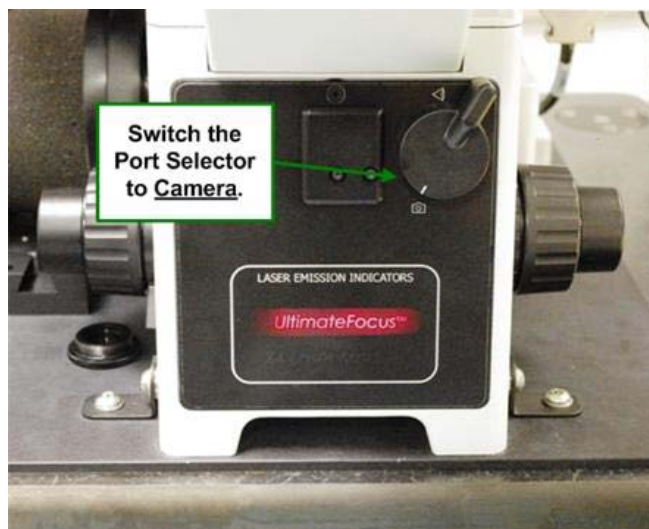

9. Adjust the T% to 50% and turn on the transmitted light.
10. Hold the Eyepiece Polarizer you removed in Step 3 in front of the camera side port and rotate the polarizer until maximum light extinction occurs. Note the orientation of the dots on the rim of the polarizer. This is the correct orientation for the Emission Filter Wheel Polarizer.

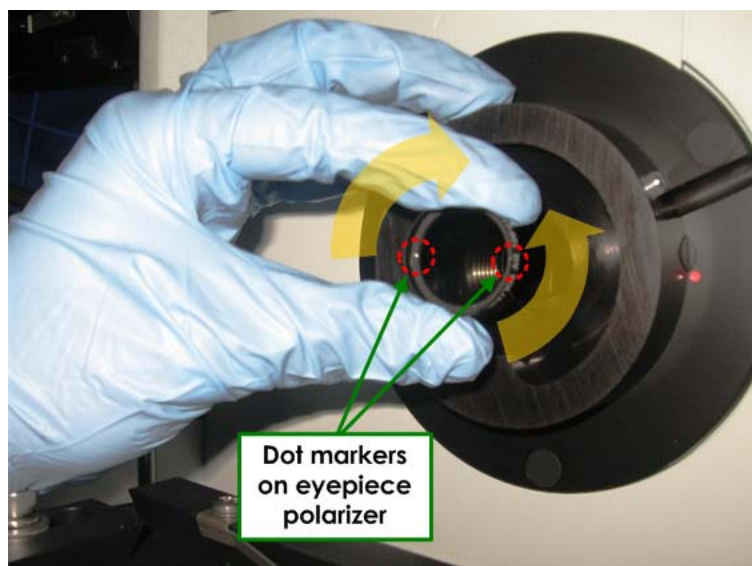

11. Use a Phillips screwdriver to remove the top plate from the Emission Filter Wheel assembly.

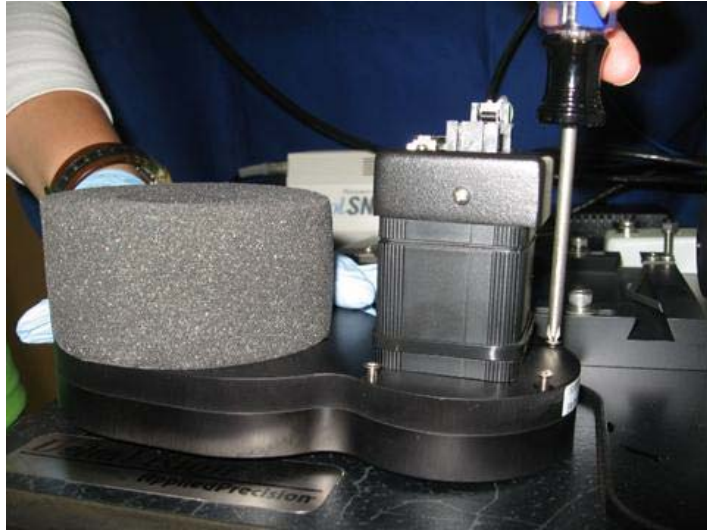

Removing the Emission Filter Wheel Top Plate



**Note** Eight Phillips screws hold the EM filter cover in place. Some of the screws are located beneath the foam collar.

12. Holding the filter wheel in the same position in which it will be installed on the system, rotate the Polarizer within the Emission Filter Wheel until the orientation of the dots matches those determined for the Eyepiece Polarizer.

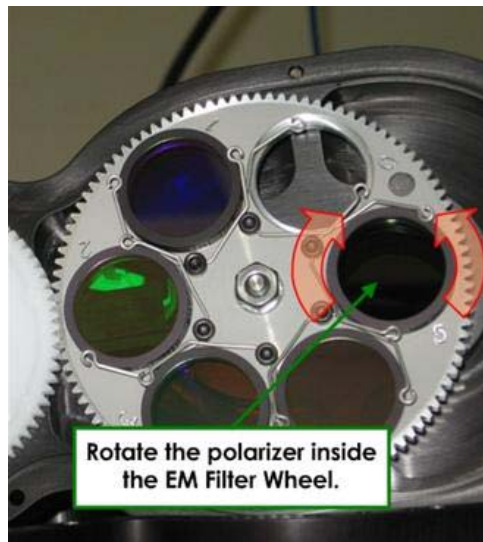



13. Reassemble the Emission Filter Wheel and reinstall the unit back onto the microscope. Adjust the Filter Wheel Support Screw so that the Emission Filter Wheel rests on the screw at maximum extinction as observed through the EM filter.

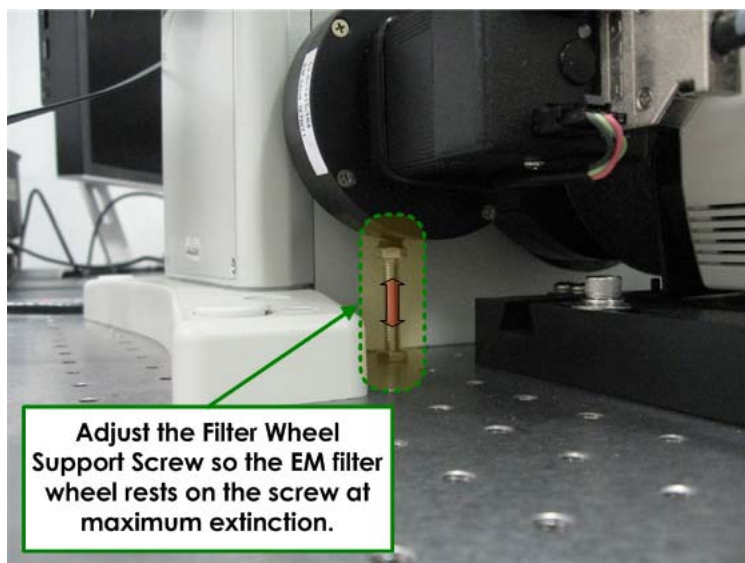

14. Repeat Steps 10 – 13 to align any additional filter wheels.



**Note** When aligning additional filter wheels, make sure the filter wheel rests on the Filter Wheel Support Screw, but **Do NOT** adjust the Filter Wheel Support Screw to achieve maximum extinction. You must rotate the Polarizer within each filter wheel assembly.

---

15. Move the camera back into its operating position on the DeltaVision system and verify extinction as follows:
- Verify that both the Condenser Polarizer and the Emission Polarizer are in the light path.
  - Acquire an image. Adjust Exposure Time and %T to obtain maximum intensity between 500 and 1500 counts.
  - Acquire images continuously (**File | Continuous Acquire**) as you slowly move the Condenser Polarizer Adjustment knob until the lowest maximum intensity is reached. This point is maximum extinction. This point should be close to the center of the knob's travel, with the maximum intensity increasing on either side.



**Note** If a minimum intensity cannot be found, the orientation of the Emission Filter Wheel must be adjusted.

---

- Tighten the Condenser Polarizer Adjustment knob at maximum extinction.

**To cross the Eyepiece Polarizer with the Condenser Polarizer:**

1. Return the Eyepiece Polarizer to the Eyepiece Filter Wheel with the arrows facing away from you.



2. Switch the Port Selector on the front of the microscope to the **Eyepiece**  icon.

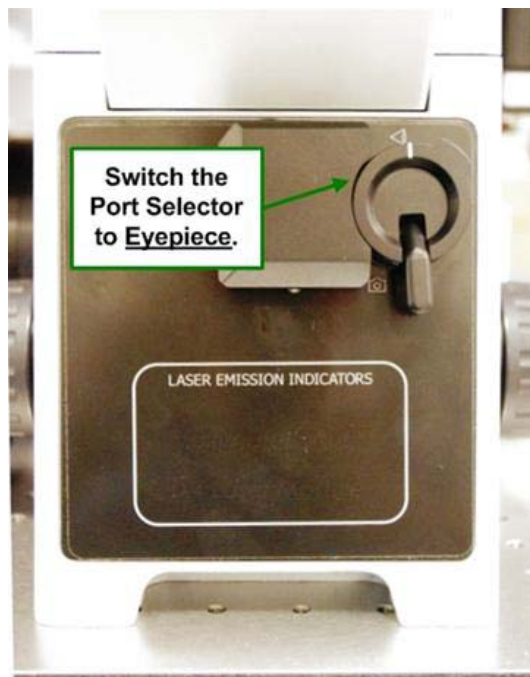

3. As it rests in its holder, rotate the Eyepiece Polarizer until maximum extinction is achieved.

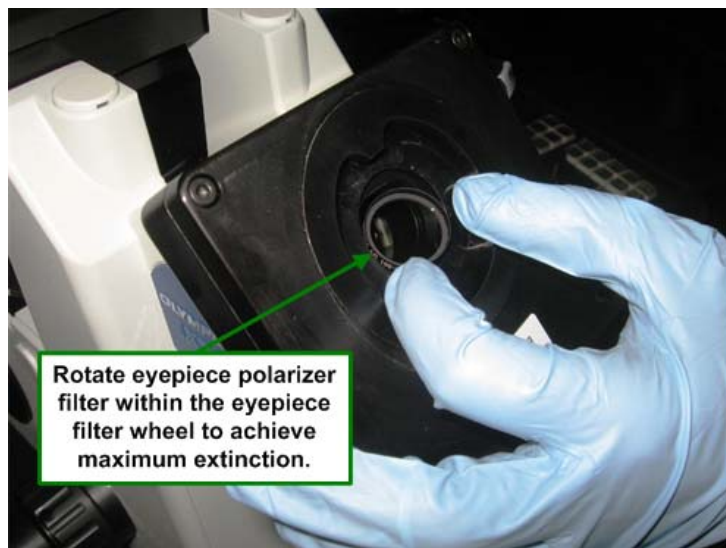

4. Return the white Eyepiece assembly to the Eyepiece Filter Wheel on the microscope base and tighten with a 3mm hex key.



Reconnecting the Eyepiece

## Setting Up DIC

After you have completed all of the DIC alignment tasks described previously, you are ready to perform the DIC setup procedure.

### To set up DIC:

1. Verify that all three of the polarizers (Condenser, Emission, and Eyepiece) are in the light path.

2. Move the Condenser Prism Turret to the correct position for the selected objective.

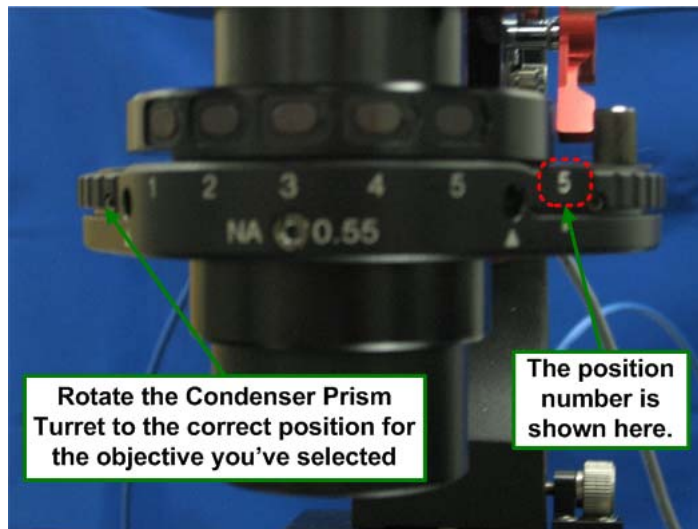

**Note** The above image does not show the objective labels that would normally be visible above the numbers.

3. Move the Principal Prism Slider into the light path under the objective (it will click into place). For proper orientation, be sure that the writing on the slider is facing down.

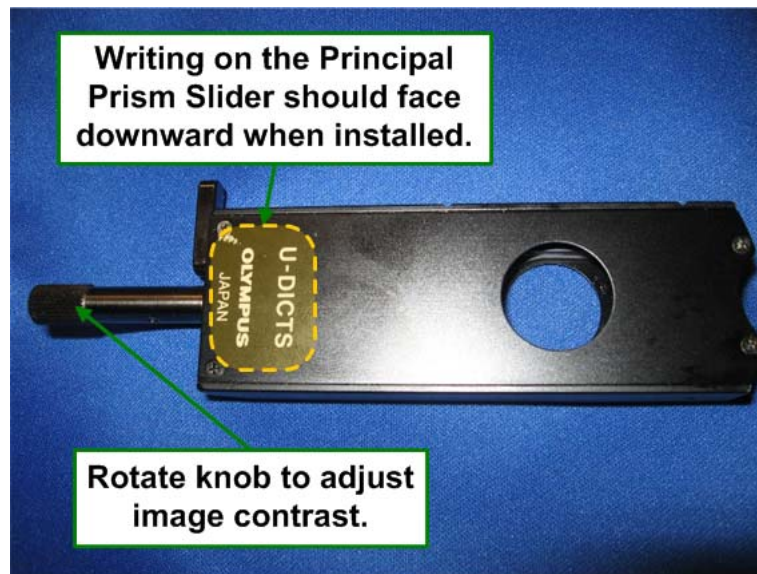

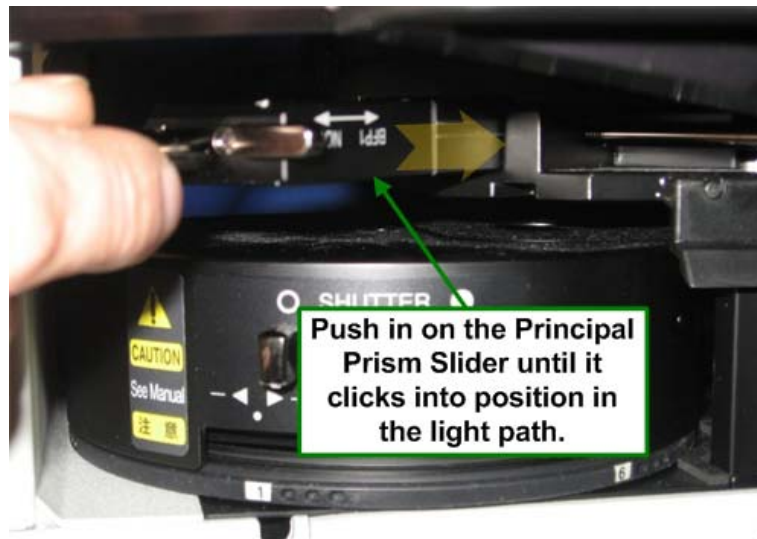



The Principal Prism Slider has two positions: **Normal** and **BFP1** (as shown below). The selected position will depend on the type of objective being used. If you are unsure, check the objective. It will say **BFP1** if that is the correct position.

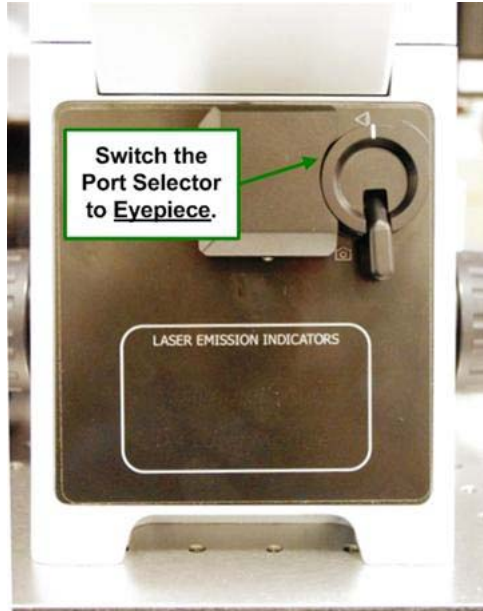

4. Switch the Port Selector to the **Eyepiece**  icon.



5. Return the sample to the stage to begin imaging.
6. Switch the Port Selector to the **Camera**  icon.



7. Acquire images continuously (**File | Continuous Acquire**) as you rotate the knob on the Principal Prism Slider to adjust the contrast displayed in the images. For example, move the shadows from bottom to top and move the black line into or out of the image.



## Consumable Parts

### Common to 100-120 V and 220-240 V Systems

Component	Fuse for Component	Part Number
IC/MIC	4A, 250V UL	22065927
Microscope	T5AH	Used in some older DeltaVision systems
X4 Laser Module	4A, 250V UL	22065927
Xenon Ballast	6.3A, 250V	28964857

### Bulbs (If applicable)

Component	Part Number
250W Xenon Arc Lamp Bulb	34-100390-000
LED Transmitted Light (must replace entire assembly)	52-851243-000

### British Power Cord

Component	Fuse for Component	Part Number
Power cord with Bussman TDC180- 10A 10A built into plug. (Must meet British Standard BS1362.)		19-210046-000

In addition to these specific parts, objectives, filters, laser heads, slides, and batteries for DeltaVision are also considered consumable parts. Check with your GE representative for additional information on consumable parts.



## 9. Changing Cameras and Filters

---

This chapter provides the following instructions for cameras and filters:

- Changing Cameras
- Using Live Cell or Custom Filter Wheel Modules
- Changing Filter Wheel Modules
- Calibrating Filter Wheels

### Changing Cameras

Your DeltaVision system may include up to two connected cameras. If you have the optional EMCCD camera, you can change cameras to better meet your imaging needs.

These instructions show how to change the camera and how to select the new camera in Resolve3D.



**CAUTION!** Contamination from fingerprints or dust on the camera window or inside the Emission filter wheel will degrade image quality.

---

#### To change the camera:

1. Remove the camera cover by lifting it up and sliding it away from the microscope.

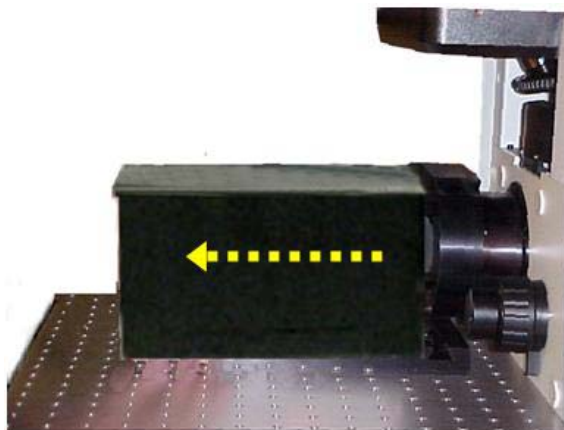

2. Remove the camera by pushing in and then pulling up on the camera end. You do not need to remove cables from the camera.

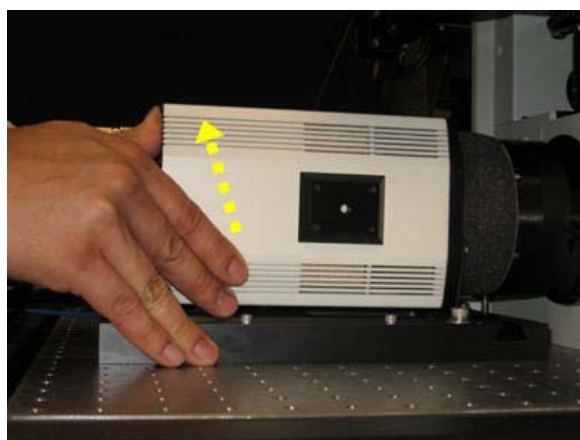

3. Remove the other camera from the spare camera tray and set it aside. Place the camera that you just removed on the spare camera tray.



**CAUTION!** Always place the camera in the camera tray when it is not secured to the system. Dropping the camera will cause severe damage.

---

4. Install the new camera by sliding it into place and then pushing in and pressing down on the end of the camera.
5. Replace the camera cover.

**To select the camera:**

1. In the Resolve3D window, click the **Settings** icon to open the Resolve3D Settings window.
2. On the **Imaging** tab, click the Camera list and select the camera that is currently installed.

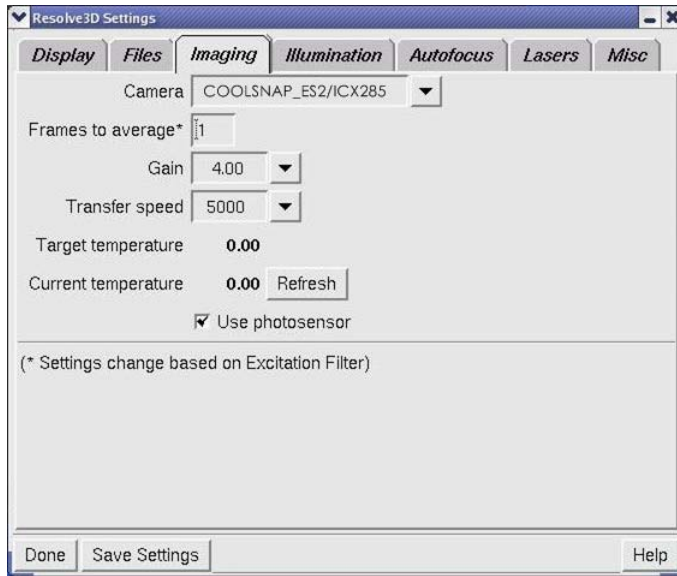

### Notes

**#1** The EMCCD camera is listed twice in the Camera list:

**CASCADE2\_512 Conv./...** sets the camera in Conventional mode.

**Cascade2\_512 EMCCD/...** sets the camera in electron-multiplication mode.

**#2** When the camera is changed, the binning number is reset to 1.

**#3** If the camera cables loosen or are accidentally disconnected, you may need to restart the IC software. To reset the cables, power the camera down and consult the camera documentation.

## Using Live Cell or Custom Filter Wheel Modules

A filter wheel module includes an Excitation filter wheel for xenon light sources, an Emission filter wheel, and an Eyepiece filter wheel.

## DeltaVision Filter Wheel Module

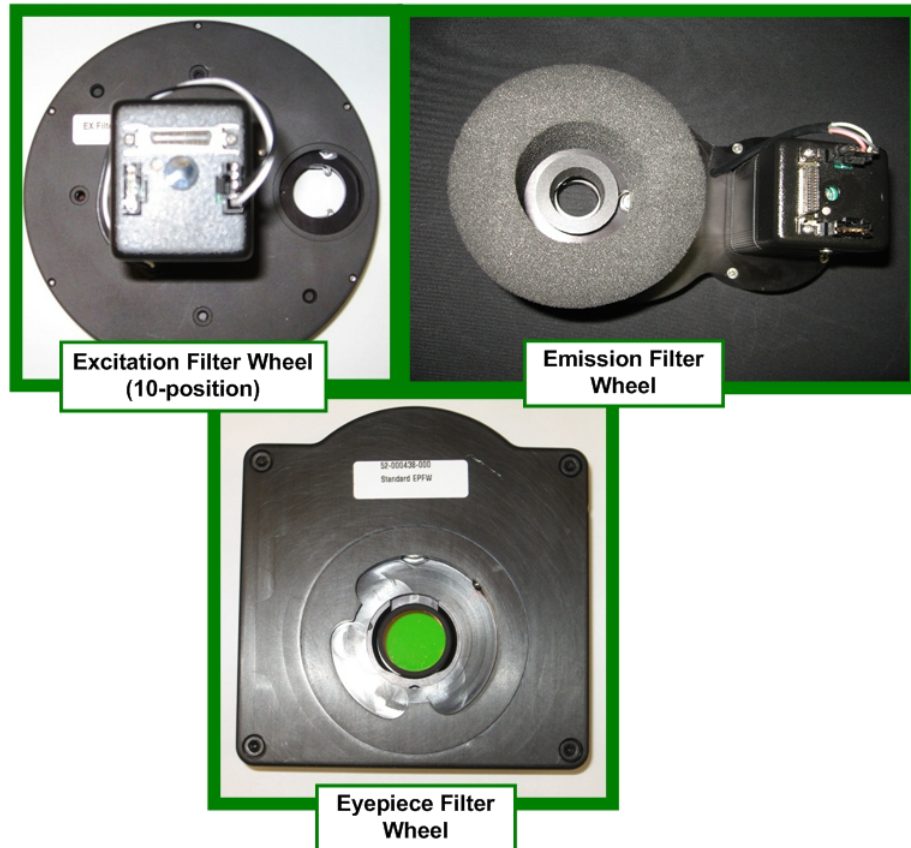

A filter wheel module includes the Excitation, Emission, and Eyepiece filter wheels and can support up to six filter pairs.



**Note** The appearance of the filter wheels will depend on the options included on your system. For example, if your system is equipped with the InsightSSI broadband light source, it may not include the excitation filter wheel described in this section.

If your system has an alternate filter wheel module, you can swap modules to meet your imaging needs.

You can purchase a module of Live Cell filter wheels that includes factory-installed filters. You can also purchase a module of empty filter wheels and customize it with your own filters.

## Changing Filter Wheel Modules

Changing the filter wheel modules for your system includes changing the Eyepiece and Emission filter wheels and, depending on how many filter pairs are supported, may also include changing the Excitation filter wheel.

If you purchased a filter wheel module as a separate component after you purchased your system, you must configure the instrument controller for the new module the first time that you use it (see the instructions included with your filter wheel module).

## Before You Begin

Before you begin the process of changing filter wheel modules, it's helpful to understand the entire procedure in general.

Basically, the procedure for changing filter wheels is as follows:

- a. Turn the IC/MIC off.
- b. Change the Excitation filter wheel if necessary (not available on Insight SSI light source).
- c. Change the Emission filter wheel.
- d. Change the Eyepiece filter wheel.
- e. Restart and initialize the IC/MIC.
- f. Select the new filter modules in the R3D **Misc** tab.

The following subsections will walk you through the procedures for changing each of the filter wheels.

## Changing the EX Filter Wheel

**To change the Excitation Filter Wheel (if necessary):**

1. Ensure that the IC/MIC is turned off, and make sure that any attached xenon arc lamps have been off and allowed to cool for several minutes.
2. Loosen the two silver thumb screws at the top and bottom of the filter wheel housing.



Loosening top thumb screw from filter wheel housing



Loosening bottom thumb screw from filter wheel housing

3. Loosen the Light Seal thumb screw to disengage it from the beveled support on the Excitation filter wheel housing and gently slide the filter wheel housing outward from its mounted position.

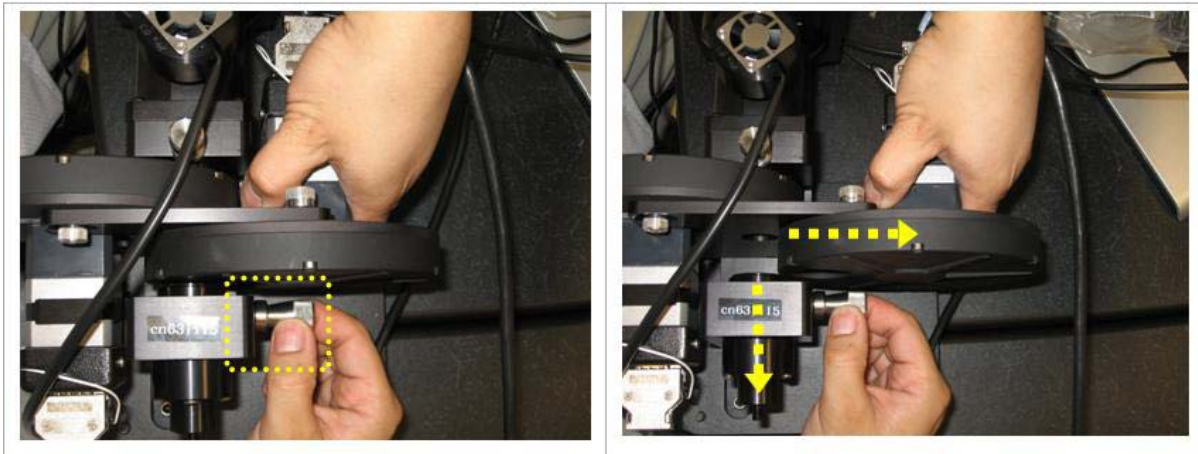

Removing the Excitation Filter Wheel housing from its mounted position

4. Disconnect the cable to the IC/MIC from the Excitation filter wheel and connect it to the alternate Excitation filter wheel.



**Disconnecting the IC/MIC cable from the Excitation Filter Wheel**

- Slide the alternate Excitation filter wheel housing back into its mounting position by pulling back on the assembly as shown.

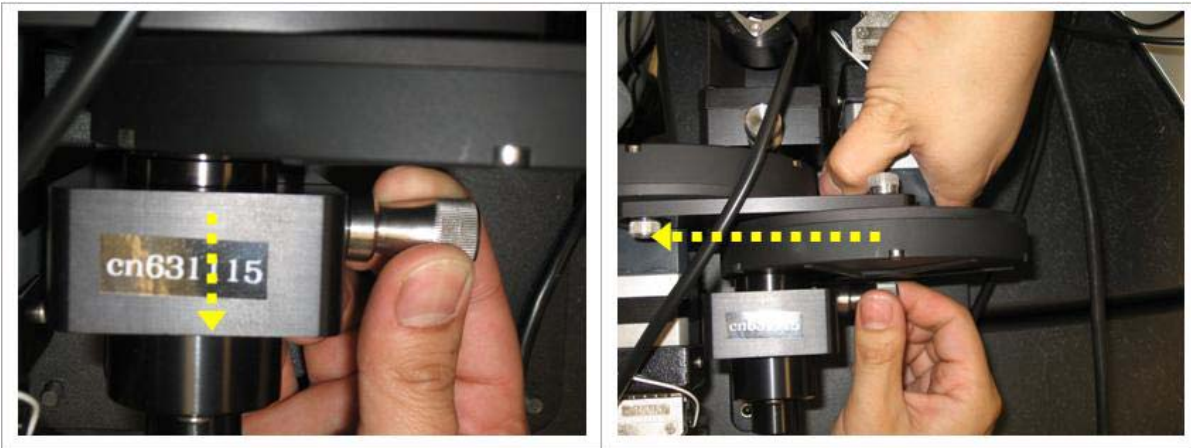

**Pulling back the housing and re-engaging the filter wheel**

- Re-engage the housing into the beveled support on the new Excitation filter wheel housing and align and tighten the two thumb screws at the top and bottom of the Excitation filter wheel housing.
- Re-engage the Light Seal into the Excitation filter wheel and tighten the thumb screw.

## Changing the EM Filter Wheel

### To change the Emission filter wheel (if necessary):

- Turn off the IC/MIC (if it's not already off).
- Remove the camera cover. Then remove the camera by pushing in and pulling up on the camera end as shown below.

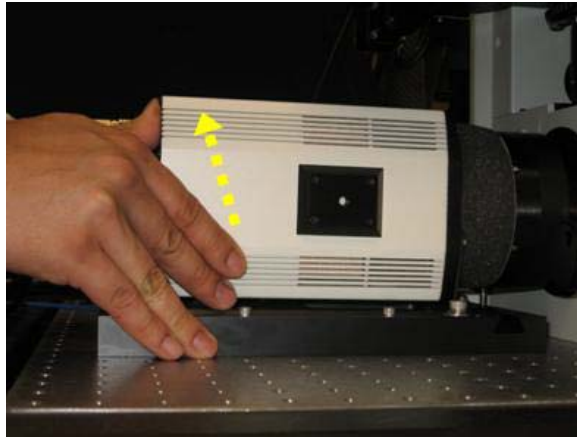

3. On the Emission filter wheel motor, disconnect the cable that connects the motor to the IC/MIC. Use a 3 mm hex key to loosen the set screw that holds the Emission filter wheel to the microscope.

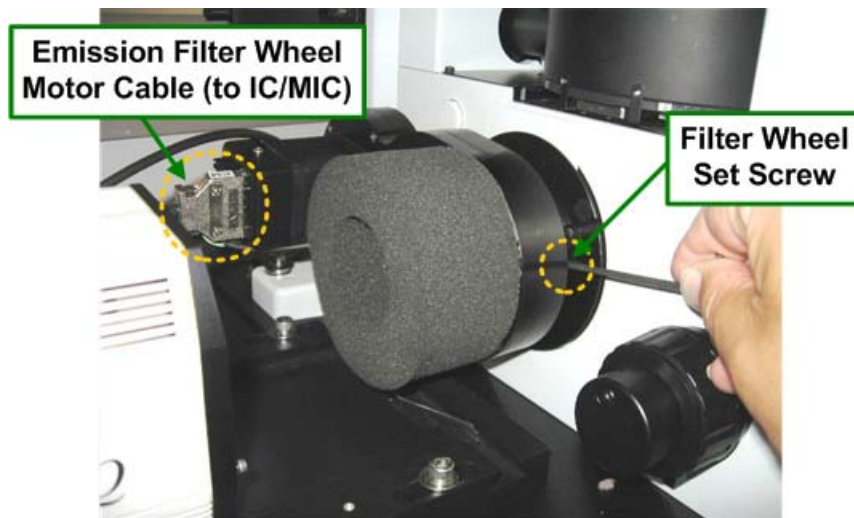

4. Remove the Emission filter wheel.



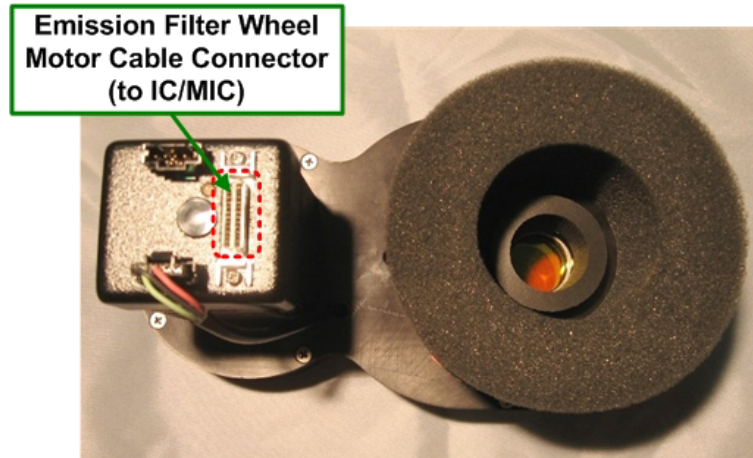

5. Install the alternate Emission filter wheel. Tighten the Emission filter wheel set screw and connect the cable from the IC/MIC to the new Emission filter wheel.
6. Reinstall the camera by sliding it into place and then pushing in and pressing down on the camera.

## Changing the EP Filter Wheel

### To change the Eyepiece filter wheel:

1. Turn off the IC/MIC (if it's not already off).
2. Disconnect the Position Sensor cable that connects the filter wheel to the IC/MIC. DeltaVision displays a message that indicates the cable is removed.

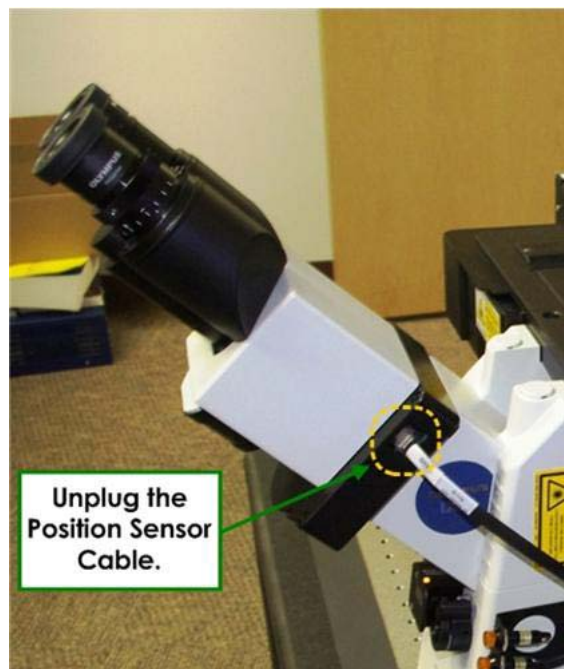

3. Holding the eyepiece in one hand, use a 3 mm hex key (Olympus provides one with the microscope) to loosen the set screw that holds the eyepiece to the Eyepiece filter wheel and set the eyepiece on the table.

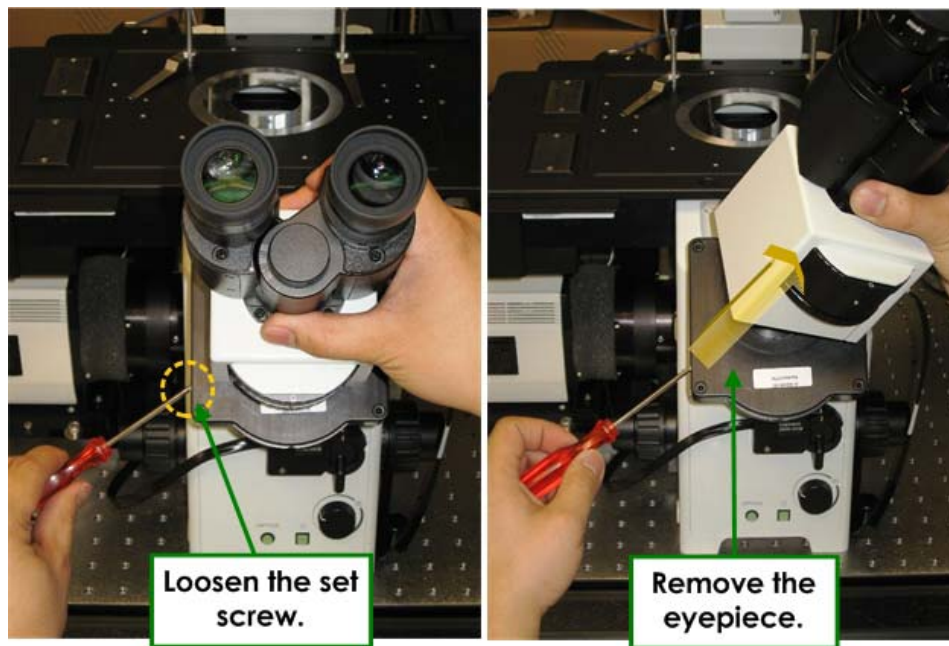

4. Loosen the set screw that holds the Eyepiece filter wheel to the beveled mount on the stand and remove the Eyepiece filter wheel.

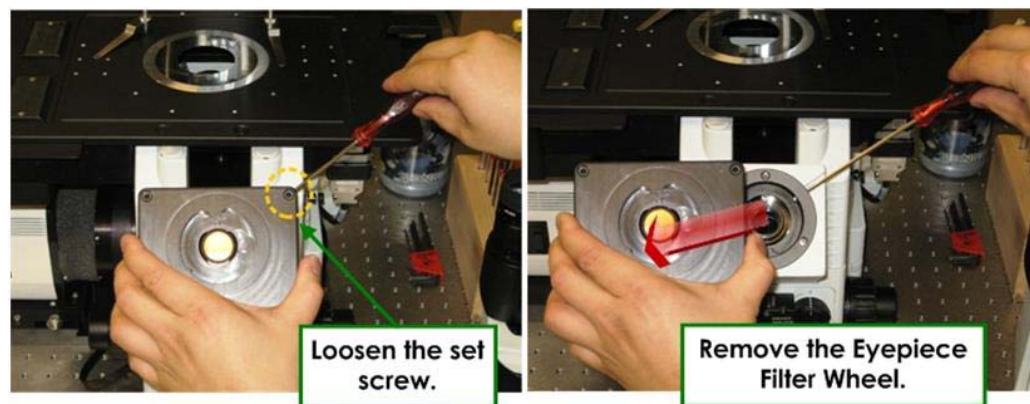

5. Place the new Eyepiece filter wheel on the beveled mount on the stand and tighten the set screw that holds it in place.
6. Connect the Position Sensor cable to the new Eyepiece filter wheel. The IC/MIC will automatically start to re-initialize the EM and EX filter wheels even though the current EX and EM filter wheels have not yet been replaced. You can ignore this re-initialization.
7. Place the oculars on the microscope and tighten the set screw that holds them in place.

## Completing the Filter Wheel Change

1. When you are finished changing all filter wheels, restart the IC/MIC.
2. Open Resolve3D and wait for the system to initialize.
3. If Resolve3D does not automatically display the correct filter module, there are two ways to expressly let the system know you have installed a new filter set:
  - a. From the Resolve3D window, select **Settings**, change to the **Misc** tab, and select the current filter set.
  - b. Unplug and then re-plug in the Eyepiece filter wheel position sensor cable (see below). The system will automatically recognize which filter set the Eyepiece filter wheel belongs to and update accordingly.

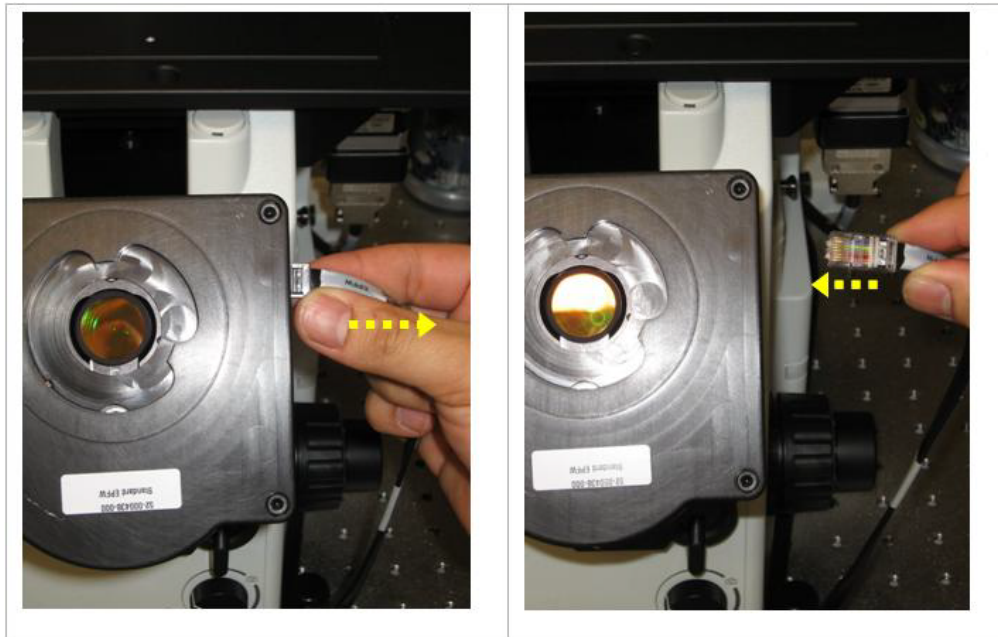

Note that it is not necessary to remove the oculars before plugging or unplugging the Eyepiece filter wheel.

4. To select the current filter set from the **Misc** tab, click the **Settings** icon on the Resolve3D main menu to open the Resolve3D Settings window. Then click the **Misc** tab.

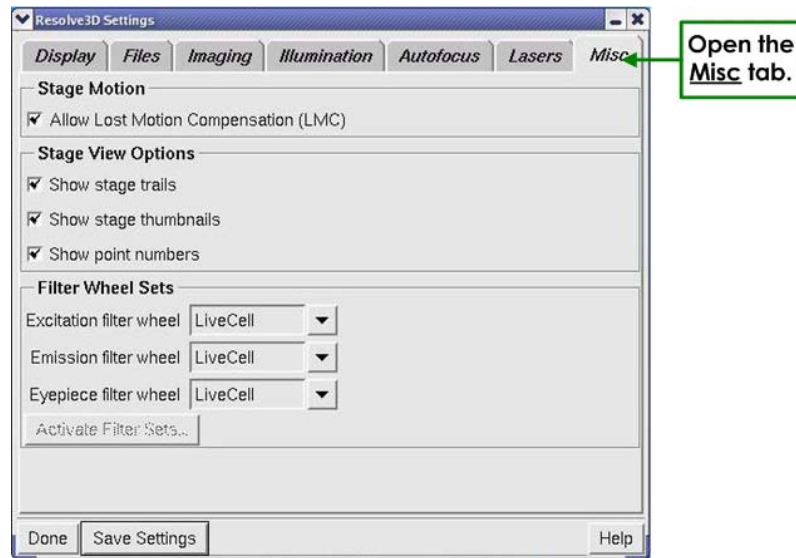

5. Select the newly installed Excitation, Emission, and Eyepiece filter wheels in their respective fields in the **Misc** tab.
6. Click the **Activate Filter Sets** button.

## Calibrating the Filter Wheels

Calibration initializes the filter positions and ensures that the filters are centered in the filter wheel openings.

If you notice poor light transmittance or poor image quality, one possible cause is a misaligned filter wheel. The filter wheel calibration re-establishes the zero position of the filter wheel for the Instrument Controller.

### To calibrate the Neutral Density, Excitation, and/or Emission filter wheels:

1. On the Resolve3D window, click the **Settings** icon to open the Resolve3D Settings window. Then click the **Misc** tab.

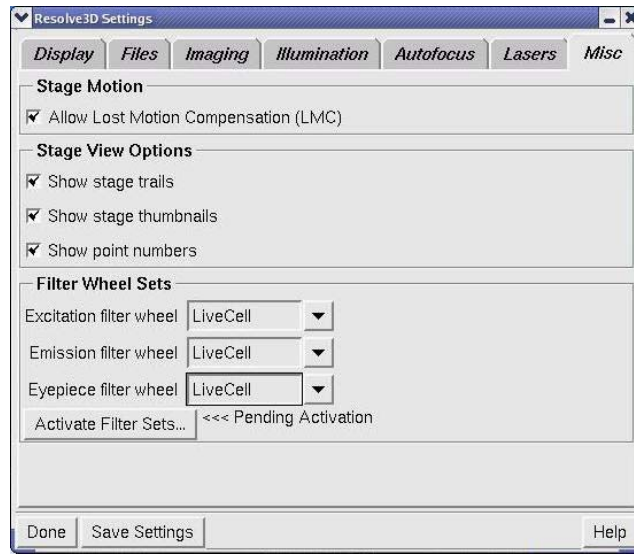

2. Verify that the **Excitation**, **Emission**, and **Eyepiece** filter wheel fields all display the expected and identical filter wheel module name (if any of the names are different, you may need to select or replace one or more of the filter wheels; see *Changing Filter Wheel Modules* on Page 9.4).
3. Press **Save Settings** and close Resolve3D.
4. Click on the Instrument Controller icon on the workstation desktop as shown.

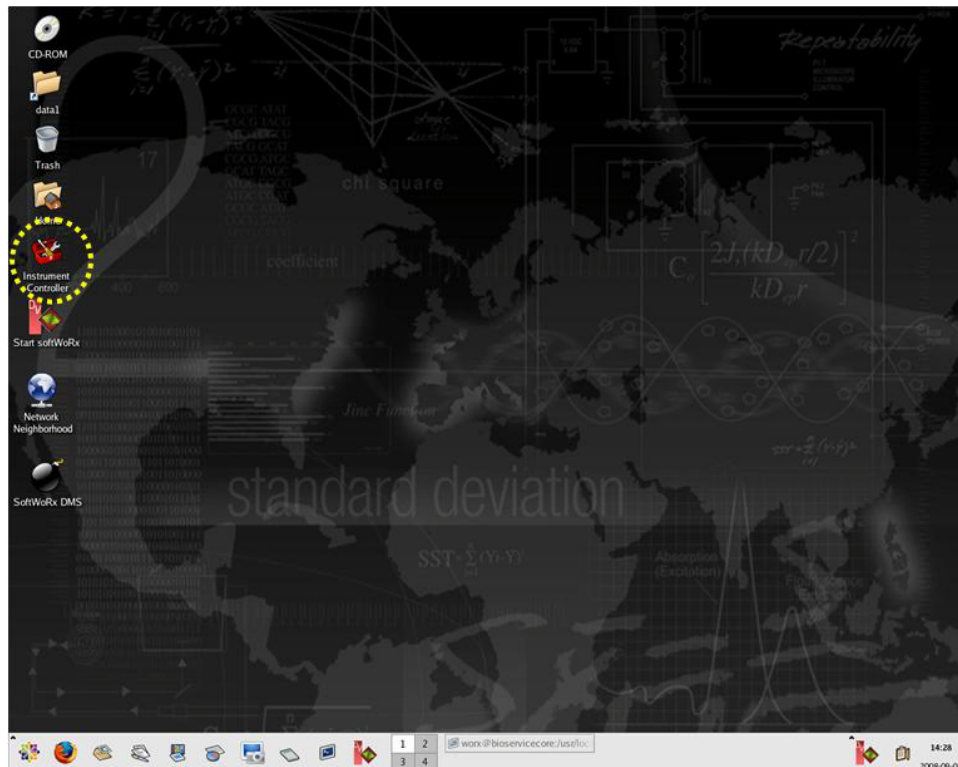

5. Log on to the Instrument Controller with the user name `worx` and password `4delta` if prompted.
6. Press `Alt + H`. The filter wheels will rotate as they are being initialized. You are then prompted with, "Calibrate the EX filter wheel (y/n)."
7. Remove the filter wheel to be calibrated (Excitation, Emission, or Neutral Density) from the system so the opening is visible.
8. If you are calibrating the Excitation Filter Wheel, press `y`. Otherwise press `n` to move to the next filter wheel (**ND** or **EM**).

When you press `y`, the following message is displayed:

```

rdesktop - 159.159.159.2
My Computer
DeltaVision Instrum...
DeltaVision Instrument ...

DeltaVision Instrument Controller 5.40
OLV_iGetCurrentMirrorPosition: motorized mirror turret is not available!
Control: Local
Starting normal operation...
EP: FITC 528 / 38
EM: FITC 490 / 20
EM: FITC 528 / 38
OLV_iGetCurrentMirrorPosition: motorized mirror turret is not available!
Searching for filter wheel home positions...
Searching for filter wheel reference points...
Calibrate the EX filter wheel (y/n)?
Use the right/left arrow keys to move the EX filter wheel.
The down/up arrow keys will move one filter position.
Press ENTER when the first filter hole is centered.
Calibrate the ND filter wheel (y/n)?
Calibrate the EM filter wheel (y/n)?
Use the right/left arrow keys to move the EM filter.
The down/up arrow keys will move one filter position.
Press ENTER when the first filter hole is centered.
EM wheel position: 2.769
EM wheel position: 2.764
EM wheel position: 2.769
EM wheel position: 2.774
Save the new filter offsets (y/n)? y
New filter offsets saved.
  
```

Pressing the up or down arrow keys advances the filter wheel one complete position. The left and right arrow keys move the filter wheel in small increments.

9. Find the Home filter position on the filter wheel. The Home filter position is marked on each of the filter wheels as follows:
  - EX = **1**
  - ND = **1**
  - EM = **0** (for 6-position filter wheels) or **1** (for 10-position filter wheels)

The position is stamped on the surface of the filter wheel and may be viewed through the filter wheel hole.

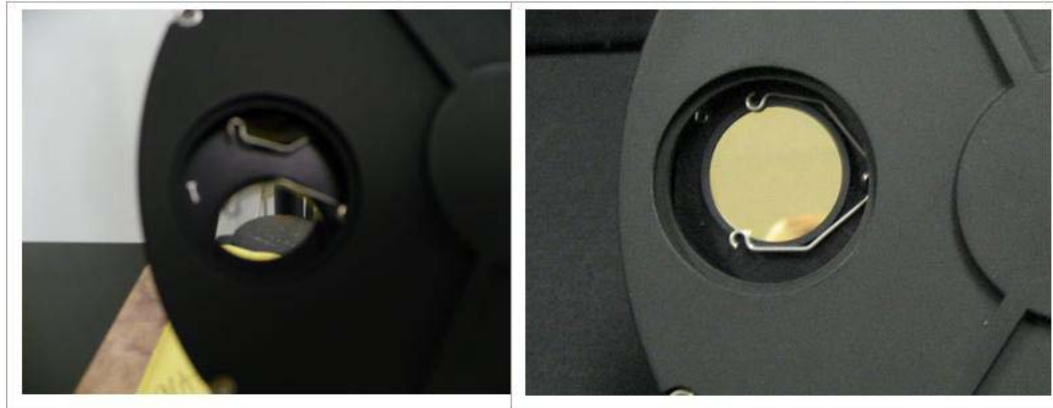

Filter position not centered

Filter position centered

10. Once the filter wheel is centered, press **Enter**. After all necessary filter wheels have been centered you are prompted with, "Save the new filter offsets (y/n)."
11. If you made a mistake during calibration you can press **n** and start the process over; otherwise press **y** to save your offsets.
12. Re-install the filter wheels in the system.
13. To shut down the IC/MIC, go to the Start tab and select **Windows Security**. Then select the **Shutdown** option.

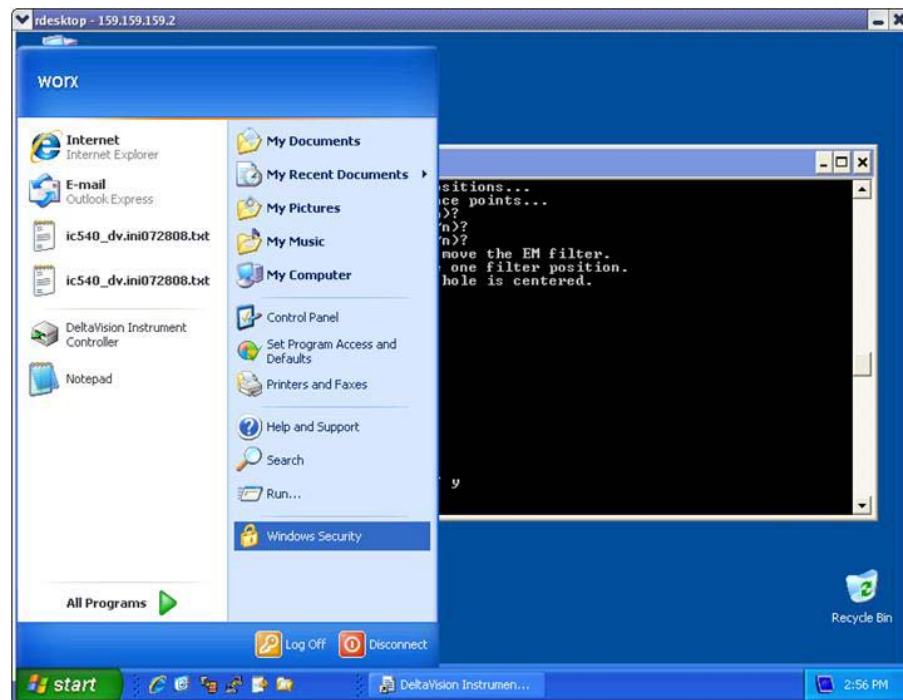

The IC/MIC will power down.

14. Power the IC/MIC back on and boot the DeltaVision as normal.





## 10. Maintenance

---

This chapter provides the following instructions for the basic maintenance of a Deltavision system:

- Shutting Down and Starting the System
- Replacing the Xenon Bulb
- Replacing IC/MIC Fuses
- Cleaning the System
- Moving the System

### Shutting Down and Starting the System

Use the following instructions for shutting the system down during occasions that require total shutdowns.

#### DeltaVision Power Switches

The main DeltaVision power switches are shown below.

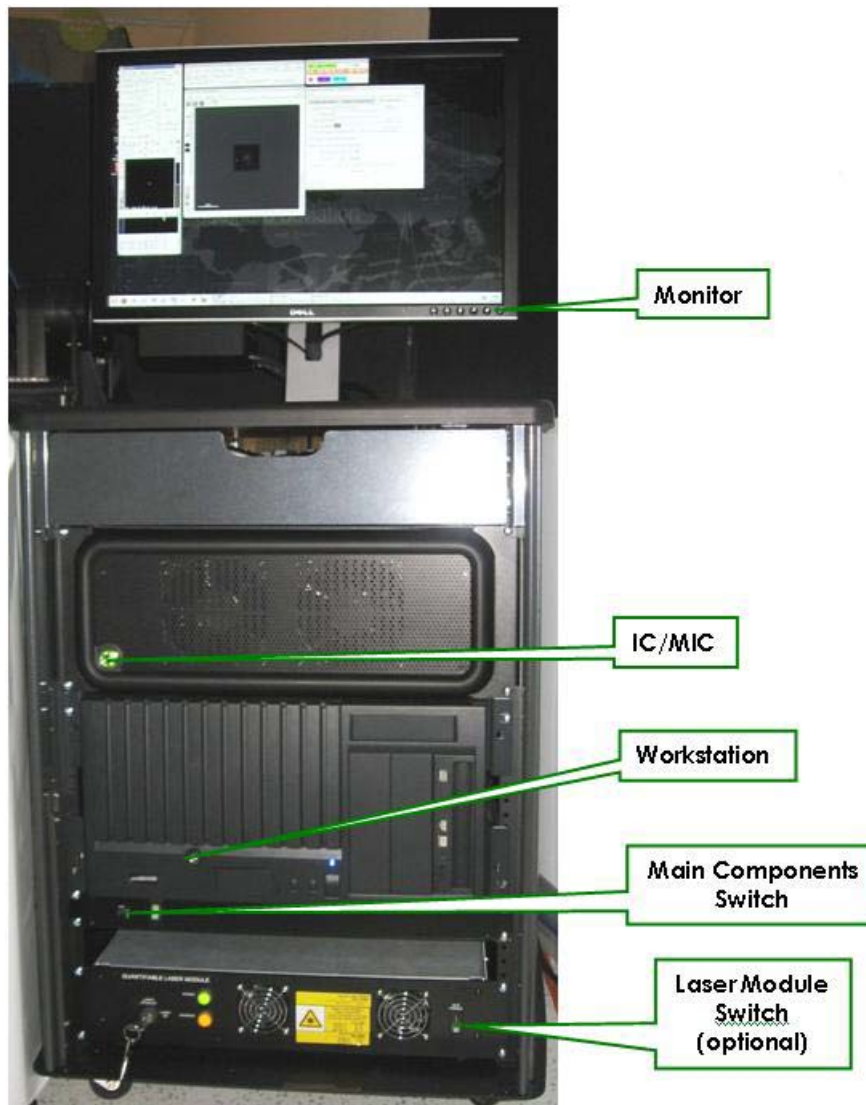

## Guidelines for Using Switches

### Main Components

Use this switch to turn power on and off for the Camera Power Supplies, the optional Laser Module, and some of the other optional DeltaVision equipment.

### Workstation, IC/MIC, and Monitor

Leave these switches on except on rare occasions (such as power outages) when you need to shut down the entire system.

## Shutting Down the System

In some situations, such as power outages, you will need to shut down the entire DeltaVision system.

### To shut down the DeltaVision system:

1. Save all data on the workstation.
2. On the *softWoRx* menu bar, choose **File | Exit**. Then exit all other workstation applications.
3. From the main menu button, choose **Logout** and then **Shut Down**. Wait until the monitor displays *Power Down*.
4. Press the power button on the IC/MIC once to shutdown.
5. Turn off the monitor.
6. Turn off the main component switch.
7. Clean the objective if necessary.
8. Lower the objective.

## Starting the System

Use the following instructions to start the system after a total shutdown.

### To start the DeltaVision System:

1. Turn on the power strip bar.
2. Turn on the IC/MIC.
3. Turn on the workstation.
4. Turn on the monitor.
5. Follow the instructions for turning on DeltaVision on Page 3.7.

## Replacing the Xenon Bulb



**WARNING!** Ensure the xenon lamp is off and has had plenty of time to cool before starting this procedure. Refer to the "Xenon Lamp Safety" section in Chapter 2 of this manual for details on safety issues and proper disposal of the lamp.

---

Follow these steps to replace the xenon bulb on DeltaVision:

1. If the system is on, exit *Resolve3D* and ensure that the IC/MIC is off prior to proceeding. The fan on the lamp housing must be off before you begin this procedure.
2. Loosen the three hex screws in the flange of the xenon lamp housing.

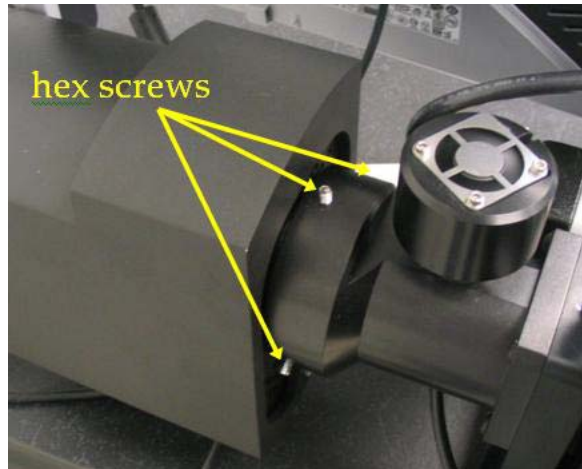

3. Gently slide the lamp housing away from the flange to remove it from the DeltaVision excitation module.



4. Loosen the two thumb screws on the opposite end of the xenon lamp housing.



5. Gently slide the internal lamp mechanism from the lamp housing.

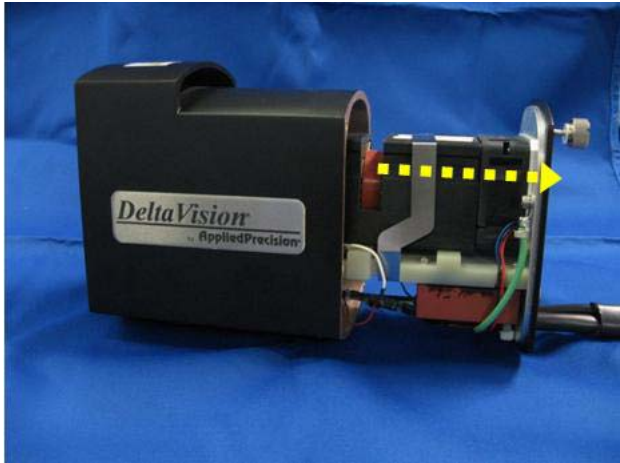

6. Remove the center clip from the internal lamp mechanism as shown.

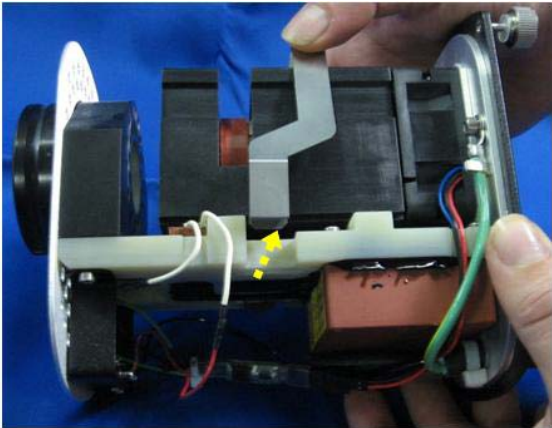
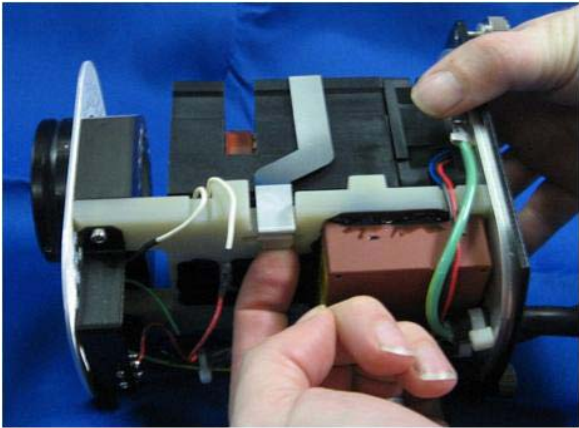

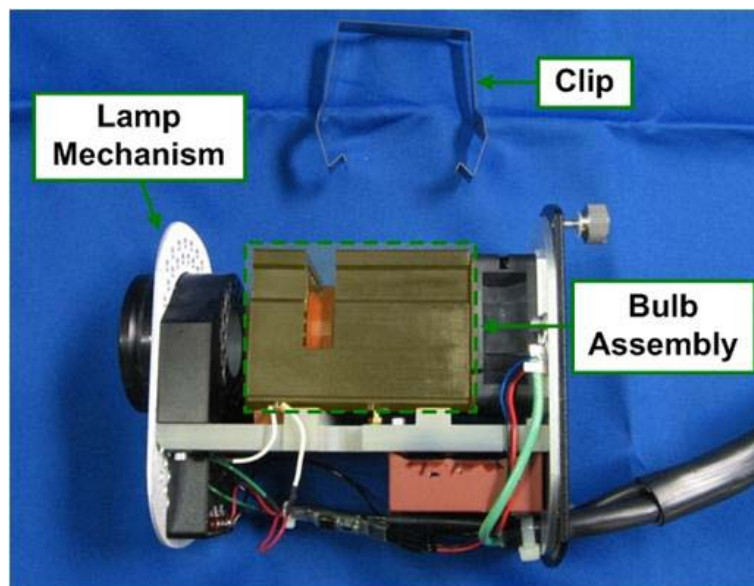

7. Lift the bulb assembly (small black box) from the two supporting pins in the lamp mechanism.

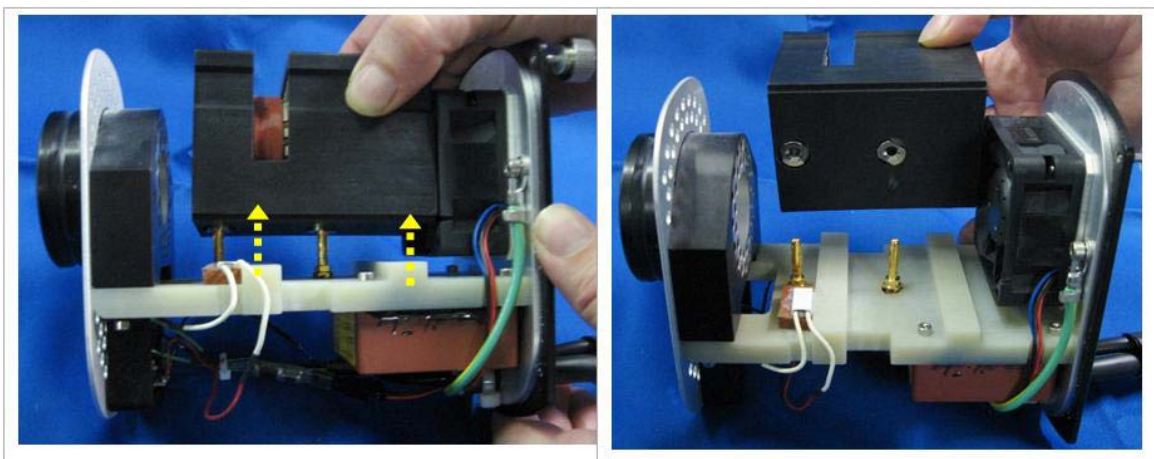

8. Replace the xenon bulb assembly with a new one (Part #34-100390-002). Insert the new bulb assembly onto the two supporting pins and press down firmly.

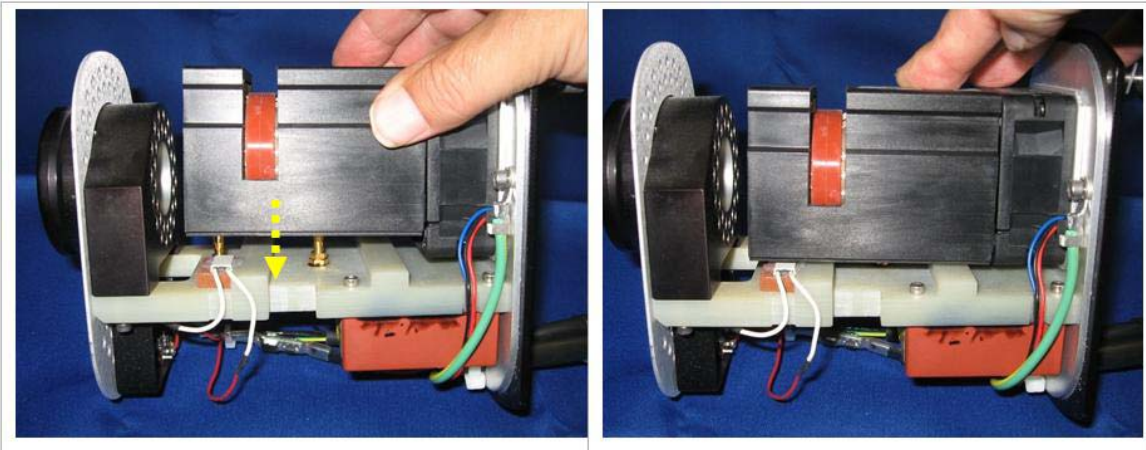

9. Replace the clip around the internal lamp assembly, making sure the clip is properly oriented.

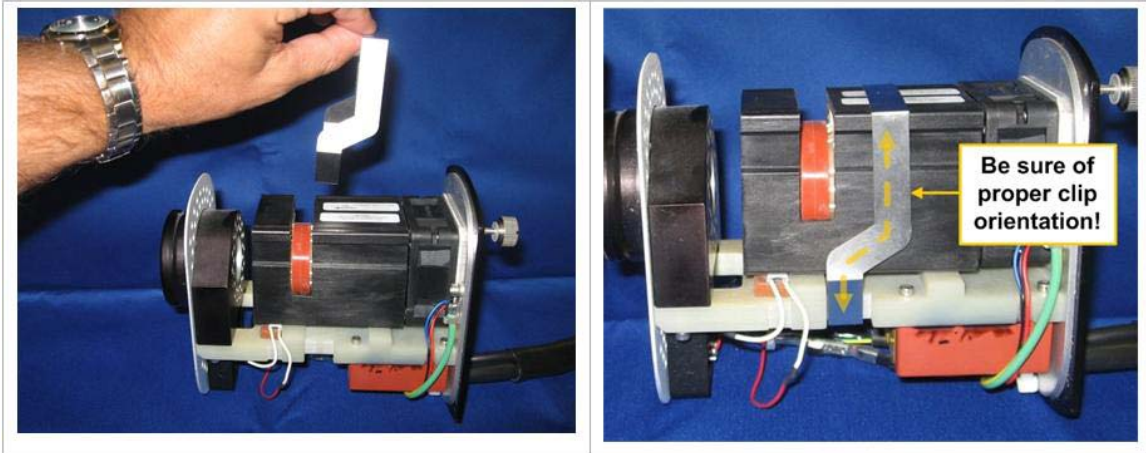

10. Gently slide the internal lamp mechanism into place within the lamp housing.

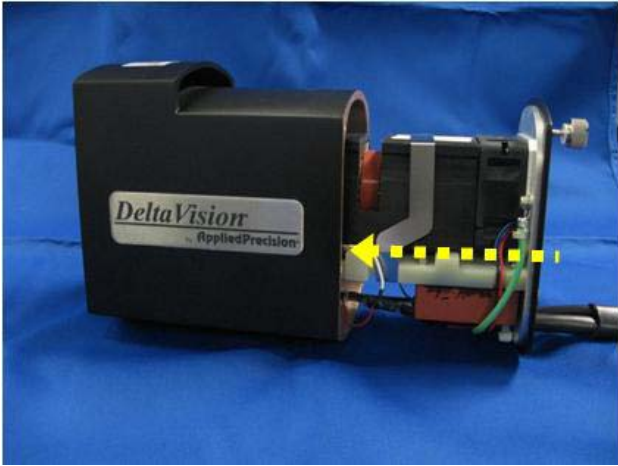

11. Tighten the two thumb screws on the end of the lamp housing.



12. Place the open end of the lamp housing over the flange on the DeltaVision and tighten the three hex screws as shown.

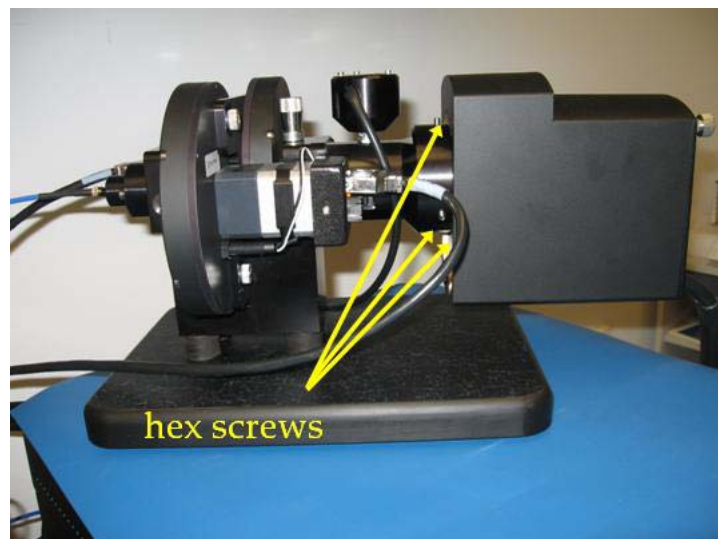

13. Turn the DeltaVision on as usual and start Resolve3D.
14. Before resetting the bulb age, write down the age of the bulb you just replaced. This will help you to keep track of when you may need to replace the next one.
15. Open the **Imaging** tab in the Resolve3D Settings window and click the **Reset** button to reset the bulb age.



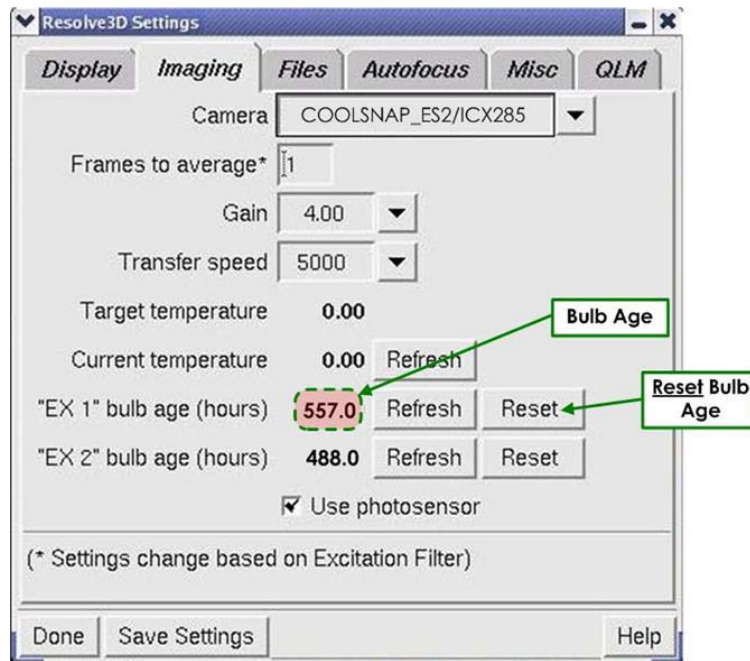

**Note** For DeltaVision systems with the Multiplexed Wavelength option installed, the procedure for changing the xenon bulb in the secondary lamp housing is identical to the procedure described above.

## Replacing IC/MIC Fuses

Follow these instructions to replace a fuse in the IC/MIC. To replace fuses for other components, follow the instructions in the manuals that are provided for those components.



**CAUTION!** Installation of improperly rated fuses can cause damage to the system.

### To replace a fuse:

1. Shut down the system.
2. Unplug the power cord on the back of the IC/MIC.
3. Remove the fuse holder.
4. Test the fuses with a continuity meter.
5. Replace any bad fuses with 5X20mm HE SB 4A 250V IEC fuses (GEHC P/N 22065927).
6. Install the fuse holder.
7. Plug in the power cord.

## Cleaning the System

Most system surfaces are best cleaned with a lint-free cloth or lint-free swabs and spectroscopy-grade isopropyl alcohol or chloroform. Avoid contaminating the cleaning solution by never reusing the cleaning cloth or swabs. Operators should be trained in the handling of flammable liquids such as alcohol. Material Safety Data Sheets (MSDS) should be maintained for the cleaning solutions, as with any hazardous material.

The exceptions to this cleaning practice are the polychroic mirror and the optical filters. These components should be cleaned with low-pressure air. For example, use a bulb designed for cleaning camera lenses, which blows air across the surface. Do not use high pressure. Do not use canned air, as this often leaves a fluorescent residue.

To clean the microscope, follow the instructions in the manufacturers' manuals that are provided for these components.



**WARNING!** If any liquid, including immersion oil, is spilled on or around the instrument, unplug the instrument immediately and clean up the spill completely. **DO NOT PLUG THE INSTRUMENT INTO ANY POWER MAINS UNTIL THE PROBLEM IS RESOLVED.**

---



**CAUTION!** Improper cleaning of the polychroic mirror and the optical filters will result in damage.

---

## Moving the System

The DeltaVision Imaging System is a very sensitive and complex instrument. The system should not be moved by anyone other than a qualified GE representative. If you need to move your DeltaVision system, contact your GE representative for instructions.

## Appendix A. The Immersion Oil Kit

---

The immersion oil kit is a collection of oils with refractive indexes that range from 1.500 to 1.534. Use of the correct immersion oil decreases the spherical aberration in the image data.

- For DeltaVision, the immersion oil kit includes eighteen oils that range from 1.500 to 1.534, in increments of 0.002.



**Note** For personalDV, the immersion oil kit includes six oils that range from 1.512 to 1.522, in increments of 0.002.

---

Many factors influence the optimum refractive index of the immersion oil, including specimen preparation, temperature, humidity, and atmospheric pressure.

### The Oil Calculator

In order to calculate the desired refractive index, *softWoRx* is equipped with the Lens Information function. This function is located in the Utilities menu in *softWoRx*. It can also be accessed from Resolve 3D by clicking the **Info** button. The following parameters are explained here to help you enter the appropriate information and use the resulting calculations.

#### Distance from Coverslip to Specimen (microns)

Establishes the distance from the surface of the coverslip to the desired focal plane.

#### Temperature

Defines the temperature of the specimen and the immersion medium.

### Specimen Refractive Index

Defines the refractive index of the specimen, which is usually that of the mounting medium. In some cases, the specimen itself contributes significant refraction.

### Recommended Refractive Index

Displays the resulting optimal refractive index of the immersion oil. Actually experimenting with oils with refractive indexes very close to this value is the best way to select the optimal oil.

### Resolution Ratio

Displays the ratio between the Z resolution and the XY ratio. This serves as a reference to the degree of Z elongation.

### Maximum XY Pixel Size

Displays the maximum recommended XY pixel size for deconvolution.

### Recommended Z Step

Displays the smallest possible Z step for this objective. Choosing a smaller Z step will add to the size of the image file, but will not improve image quality.



**WARNING!** If any liquid, including immersion oil, is spilled on or around the instrument, unplug the instrument immediately and clean up the spill completely. DO NOT PLUG THE INSTRUMENT INTO ANY POWER MAINS UNTIL THE PROBLEM IS RESOLVED.

---

# Appendix B. Troubleshooting

---

This appendix was designed to help you diagnose and correct the most common problems encountered on a DeltaVision system. Two types of troubleshooting tasks are covered:

- Diagnosing System Problems
- Analyzing Reasons for Poor Image Quality

If you are unable to correct a problem, contact your GE Healthcare representative.

## Diagnosing System Problems

### Troubleshooting the Controller

The following table shows the most common Instrument Controller problems and their resolutions.

Table B-1: Controller Troubleshooting Chart

Indication	Cause	Correction
Encoder Error when initializing stage.	Poor cable connection.	Power down system, including IC/MIC. Reseat X, Y, and Z motor cables. Reseat motor cables on excitation module. Power up system.

## Troubleshooting the Workstation

Other system troubles are indicated by messages or readings in the software. The Resolve 3D message window displays Resolve 3D activity. Observe the messages in this window when troubleshooting. This table shows possible problems and corrective actions.

Table B.1 Table B-2: Workstation Troubleshooting Chart

Indication	Cause	Correction
"File system full" message when trying to save images	There is no more storage space for image data.	Delete unwanted files. Save image files to CD or DVD or LAN. See <a href="#">softWoRx Imaging Workstation User's Guide</a> for more information.
"Camera not found" message	Power up sequence was incorrect.	Shut down the system and then restart it using the steps described in <i>Chapter 10: "Maintenance."</i>
Resolve 3D settings are not updating changes made using the keypad or joystick (for example, the filter selection, or Z position).	Lack of communication between the Instrument Controller and Workstation	Shut down the system and then restart it using the steps described in <i>Chapter 10: "Maintenance."</i>
At login, user name not recognized.	User has not been added.	Add user. See the <a href="#">softWoRx Imaging Workstation User's Guide</a> .

## Analyzing Reasons for Poor Image Quality

The following table documents the most common acquisition difficulties and abnormalities in image data.

**Table B.2 Table B-3: Image Quality Troubleshooting Chart**

Indication	Cause	Correction
Dim images or long exposure times.	Poor illumination.	Fully open field aperture.  Ensure that filter cube turret is locked in position on rail mount.  Ensure shutter on polychroic filter wheel is open.  Ensure slider behind microscope is seated in an open position.  Ensure proper filter cube is in position and seated in detent.
Dim illumination. When fiber optic cable and focusing lens are removed, the projected light does not form a circle.	Filter wheel(s) out of alignment.	Shut down and start up as described on Page 10.1  and/or unplug and plug in the Eyepiece filter wheel. This will reset the home position of the filter wheels and align filter wheel position.  Calibrate filter wheels following instructions on Page 9.12.
Dark, out of focus spots on image.	Dust interference.	Clean polychroic filter, emission filter, and camera window using low-pressure air. Do not use canned air. See “Cleaning the System” on page 10.10 for further recommendations regarding cleaning system components.
Image is distorted around edges or throughout. Occlusion seems to creep in toward center.	Condensation on camera window, possibly due to improper camera temperature.	Clean camera window using low-pressure air. Do not use canned air. See “Cleaning the System” on page 10.10 for further recommendations regarding cleaning system components.  Check camera temperature in Resolve3D. Consult camera documentation for proper setting.
Brightness of Z section images varies greatly.	A broken Photo sensor cable	Disconnect the Photo sensor cable and the EX module cable.  Connect the Photo sensor cable to the EX module.  Set the Excitation filter to FITC or some other visible light.  Open the EX shutter.  Bend the cable and examine it for light leaks. If you observe a light leak, replace the cable.  Direct the light to a wall. If you observe inconsistencies in the light output as you bend the cable, replace the Photosensor cable.

**Table B.3      Table B-3: Image Quality Troubleshooting Chart (cont'd)**

Indication	Cause	Correction
Image has a traveling light or bubble.	Air bubble in immersion oil.	Clean front and back surfaces of objective and coverslip.  Reapply immersion oil and restart experiment.
Interference in image data.	Possibly dirt, dust, oil, or air bubble.	Clean front and back surfaces of objective and coverslip.
Very bright image or camera saturation message.	Camera saturation.	Use lower exposure time and/or higher neutral density filter.
Z series shows uneven or off center illumination.	Poorly aligned illumination.	Align xenon lamp and fiber optic cable.  See Chapter 10, "Maintenance."
No image when <b>Acquire</b> is pressed.	Knob at base of microscope is directing light to the eyepiece.	Move knob to direct light to camera.
Z series out of focus and incomplete.	Stage was not centered within sample at start of experiment.	Position stage in center of the sample and run experiment again.



## Appendix C. Acquiring a PSF

---

This appendix shows how to acquire a Point Spread Function (PSF) and convert it to an Optical Transfer Function (OTF).

- *Acquiring a PSF* shows how to measure a Point Spread Function.
- *Converting PSF to OTF* shows how to convert the Point Spread Function to the Optical Transfer Function that is required to process images.

### Before You Start

Before you attempt to measure a PSF, check the OTF library included with *softWoRx* to find out if the library provides an OTF for your objective.

### Acquiring a PSF

To measure the point spread function (PSF), you need to optically section a fluorescent bead. Since the properties of the objective lens are the most important elements of determining a PSF, it is necessary to have the proper PSF whenever new lenses are added to your microscope. The deconvolution software adapts to the PSF (actually the OTF) wavelength, so it is unnecessary to measure the PSF at more than one wavelength.



**Note** If you do not have the tools necessary to acquire a PSF, *softWoRx* includes a utility that allows you to calculate a theoretical OTF based on the numerical aperture of the camera lens, index of refraction, and emission wavelength. If the aperture of the lens is lower than 0.75 N.A., the calculated OTF may work as well, or even better, than a measured OTF. However, if the aperture is greater than 0.75 N.A., a measured OTF will generally give you better results. For information about calculating an OTF, see the *softWoRx* online Help.

---

A carefully considered and meticulously measured PSF is a key to successful deconvolution. For this reason, make sure that you:

- Thoroughly check all imaging conditions.
- Take the time you need to get a good signal-to-noise ratio in the image.
- Find a bead that is completely isolated from others in XYZ. (Use the field stop aperture to block fluorescence if needed.)
- Completely scan the bead.

## Tools

This procedure requires the following tools:

- A clean and aligned DeltaVision system
- A bead slide with 0.1 $\mu$ m, or smaller, fluorescent beads
- A grid slide or other microscopic ruler
- An immersion oil set, if appropriate.

The following steps describe how to calculate pixel size, measure the PSF, and obtain the corresponding OTF.

### To calculate pixel size:

1. Place the new objective in the Objective Turret and set the maximum image size, best camera speed, and auxiliary magnification slider at 1X.
2. Use the Eyepiece Filter Wheel to select the FITC eyepiece filter.
3. In the Resolve3D window, select the following values:

In this Field	Select
Excitation	TRITC
Emission	FITC
%T	2%

4. Place the silicon target grid on the stage and focus it (9.995  $\mu$ m/square). Align the grid image to the vertical and horizontal axis and maximize the image.
5. Switch the Port Selector to **Camera** and click **Acquire**. Leave Data Collection Window 21 open.
6. In the Image window, choose **Tools | Measure Distances**. Then set the **Units** to **Pixels** in the Measure Distance window.

- Draw a line across the grid slide image from a point on the top left square to a point in the same relative position on the top right square.

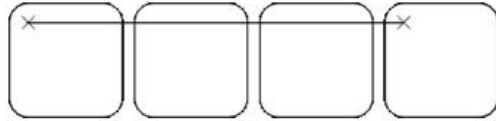

**Note** Your measurement will be more accurate if you choose points on the vertices of the squares.

- If the vertical delta is more than four pixels, re-align the slide. Repeat this process at the middle and bottom. Then count and record the number of grid elements (3 in the above image) and record the distance in pixels.
- Repeat Steps 7 and 8 in the vertical direction.
- Calculate the pixel size for each of the six measurements (top, middle, bottom, left, center, and right) as follows:

$$\text{Pixel Size}(\mu\text{m}) = \frac{9.995 \mu\text{m}/\text{box}}{\text{Measured distance (in pixels)} / (\text{Number of grids per measurement})}$$

Your calculation should be accurate to four decimal places.

- Average the six pixel sizes to obtain the correct pixel size.
- Repeat these steps for each camera attached to your DeltaVision system.

#### To add an objective to the microscope configuration:

If you are adding a new objective to the microscope, follow these steps:

- To obtain the objective lens ID number, select **Conversions | Convert PSF to OTF** from the *softWoRx* main menu. The PSF to OTF Conversion window is displayed. The current lens identification number is shown in the **Lens ID** field.
- From the *softWoRx* main menu, choose **Utilities | Revise Microscope Configuration**. Then enter the root password to open the `RESOLVE3D.SYS` file.
- In the `RESOLVE3D.SYS` file, under the Microscope Specifications section:
  - Increase the number of lenses next to `MS_Number_Lenses :` by 1.
  - Add the name of the objective to `MS_Lens_Names :` (e.g., 100Xoil, 60Xwater).
  - Add the lens ID to `MS_Lens_ID_Numbers :`
  - Enter the pixel size for the new lens.
  - For example:  
If the desired lens is 40X/1.35 with ID=10403 (the third lens in the list), then the pixel size is 0.1656.

```
MS_Lens_Names: 10X 20X 40X 60X 100X
```

```
MS_Pixel_Size_1: 0.6680 0.3313 0.1656 0.1103 0.06631 (for Coolsnap HQ2)
```

```
MS_Pixel_Size_2: 0.01 0.01 0.01 0.01 0.01 (for Evolve EMCCD – conventional mode)
```

```
MS_Pixel_Size_3: 0.01 0.01 0.01 0.01 0.01 (for Evolve EMCCD – EM mode)
```

```
MS_Lens_ID_Numbers: 10105 10205 10403 10602 10002
```

- To apply the new information, save and close `Resolve3D.sys`, then close and restart `softWoRx`.

#### To acquire a PSF:

It is easiest to find beads in a very dark room. Bead slides from GE include 1 $\mu$ m beads and 0.1 $\mu$ m beads. Both fluoresce brightly at 617 nm. Coarsely focus on the slide by positioning the lens near the slide. Scan the slide while looking for fluorescent haze from the 1 $\mu$ m beads. When you focus on the fluorescence haze from the 1 $\mu$ m beads you should also find the 0.1 $\mu$ m beads.



**Note** Although a replacement bead slide is included in the Slide kit, bead slides have a limited shelf life. To purchase bead slides from GE, contact us at the appropriate number or address listed in *Chapter 1: Getting Started*.

---

- Mount a bead slide on the microscope and focus on the beads to obtain the maximum intensity. Find a bead that is located by itself.
- Use the **Center Object** tool to center a single bead in the X and Y directions. (It is helpful to collect large images, such as 1024 $\times$ 1024.)
- Now use a 256 $\times$ 256 image.
- Adjust the CCD exposure time so that the maximum intensity at the plane of best focus is at least 2000 counts. Make sure that the camera does not saturate at the plane of best focus.
- Ensure there is only one bead in the field of view and that, as you go out of focus, no rings from other nearby beads enter the image. If necessary, use the field stop aperture to block out undesired fluorescence.
- Verify that your microscope and software are accurately configured for lens and auxiliary magnification.
- Execute the Standard PSF Measurement Macro described in the online Help to measure the standard point spread function (or run a Z series through the bead consisting of 128 sections acquired in 0.1  $\mu$ m Z increments).
- Run the `softWoRx` PSF to OTF program that converts the optical sections into an OTF. (Refer to "Converting PSF to OTF" later in this appendix.)

## Selecting the Correct Immersion Oil

Accurate PSF measurements depend on the selection of the correct immersion oil. Our experience has shown that the oils recommended by microscope manufacturers are often not ideal for 3-D microscopy. We recommend that PSFs are measured with a minimal amount of spherical aberration. Inappropriate immersion oils yield asymmetric PSF measurements as a result of spherical aberration. In the case of Olympus microscopes, an index of refraction equal to 1.518 is ideal for measuring beads that are mounted in glycerol using #1.5 coverslips. There are many variables that can affect the selection of the correct immersion oil. The `softWoRx` Lens Information program can help you select the proper oil.



**Note** An oil kit is included with your DeltaVision system. To purchase replacement oil, please contact your GE representative.

---

### To confirm that you are selecting the correct immersion oil:

1. Collect the image data. Then, in the Image window, select **Tools | Orthogonal Viewer**.
  2. Move the blue cross hair to the center of the bead in the viewer. To better see the shape of the PSF, it is helpful to do an exponential scaling—an exponent of 0.3 usually works well.
  3. Look for symmetric flare in the resulting image. Symmetry indicates that the oil is correct, and in virtually all situations, the most symmetric PSF along the Z axis is also the smallest and has the highest intensity. In other words, symmetry corresponds with the highest resolution.
  4. Repeat the process with different oils until you determine the optimal immersion oil.
- The following figure demonstrates how image flare can be affected by the use of different immersion oils.

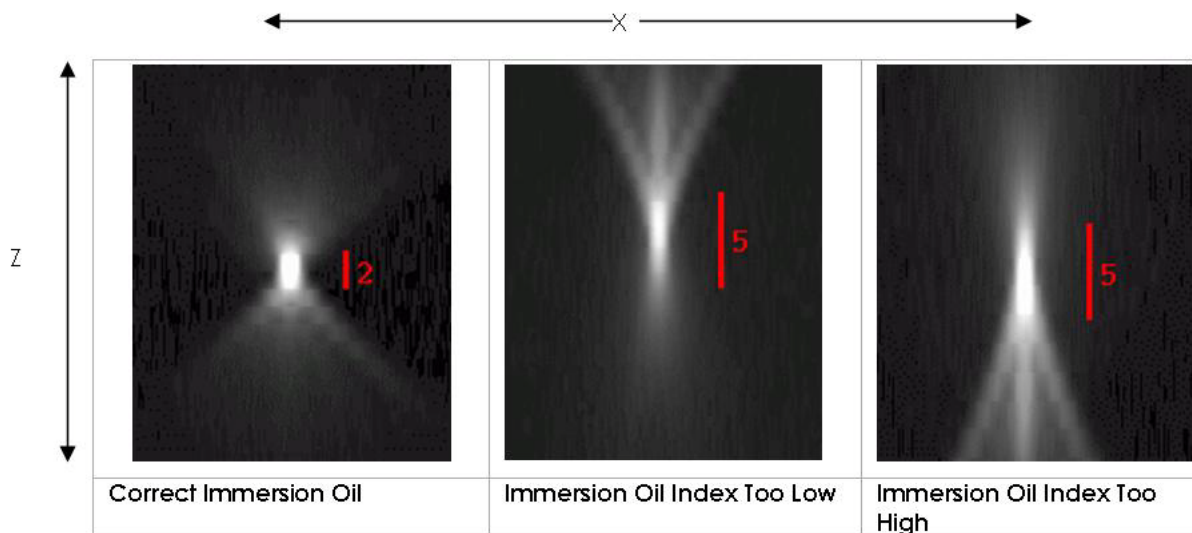

Flare from Immersion Oils (Orthogonal Views)

## Converting PSF to OTF

The PSF to OTF program converts a measured point spread function (PSF) to an optical transfer function (OTF). Essentially, the OTF is the Fourier transform of the PSF. The pixel size of the resulting image is given in cycles/ $\mu\text{m}$ . To reduce problems associated with measurement noise, the PSF is radially averaged during the conversion and, as a result, the 3D PSF image becomes a 2D OTF image.

The horizontal axis of the OTF represents axial (Z) frequency and the vertical axis represents radial (XY) frequency. The brightness of the OTF image elements, on a scale of 0 to 1, represents the frequency response of the microscope system at the corresponding radial and axial frequencies.

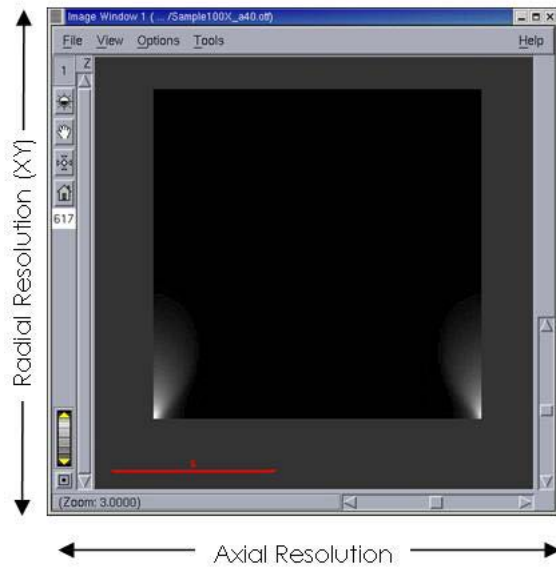

Sample OTF Image

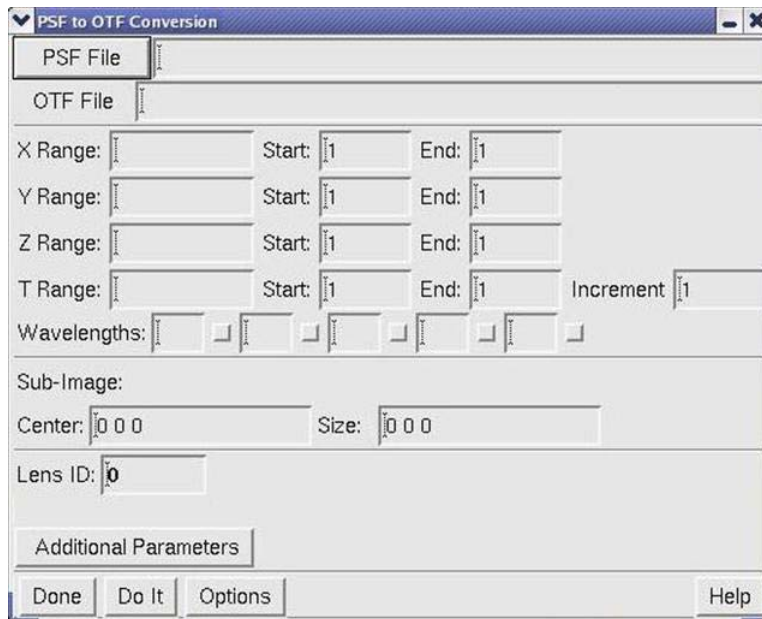

### PSF to OTF Conversion

Each option in PSF to OTF Conversion is described briefly below. For additional information regarding these options, refer to the online Help.

#### PSF File

Defines the name of the PSF image file to be converted to an OTF.

### OTF File

Displays the name of the resulting axially symmetric OTF. (For your convenience, the OTF filename is created by appending “\_otf” to the PSF filename.)

### X Range

Defines the start and end pixel numbers in X.

### Y Range

Defines the start and end pixel numbers in Y.

### Z Range

Defines the start and end pixel numbers in Z.

### T Range

This field is not used for PSF to OTF conversion.

### Wavelengths

Determined by PSF wavelength.

### Lens ID

Specifies the lens identification number (e.g., 12004).

### Sub-Image: Center

Specifies the central XYZ coordinates of the point spread.

### Sub-Image: Size

Specifies the XYZ image dimensions about the central coordinates. (The standard *softWoRx* point spread measurement is 256×256×128.)

### Additional Parameters: Border Rolloff (voxels)

Specifies the number of voxels to roll off at the edge of the image. This reduces edge effects resulting from the Fourier Transform used in the PSF to OTF conversion.

The procedure for converting a PSF to an OTF is very simple. After the PSF file has been identified in PSF to OTF Conversion, *softWoRx* assigns default settings to the rest of the options in the window. In almost every instance, these settings will be appropriate to use for the conversion.

### To convert a PSF to an OTF:

1. Click **Conversions** on the main menu bar of *softWoRx*.
2. Click **Convert PSF to OTF** in the **Conversions** menu. PSF to OTF Conversions will appear.
3. Use one of the following options to enter the PSF file to convert.
  - Drag the appropriate PSF file from the File Manager into the **PSF File** text box.
  - Click **PSF File** to display a small version of the File Manager and then choose the PSF file that you wish to convert.

- Type the desired path and filename into the **PSF File** text box.
4. Click **Do It**.

#### To place OTF into OTF Library

If the objective used is in addition to those already present, you'll need to modify *softWoRx* to use the new objective by adding the file to `/usr/local/softWoRx/config/system.swrc` as follows:

1. Log in to Linux as `root`.
2. Navigate to `/usr/local/softWoRx/config/system.swrc`
3. Find the section labeled, "Lens-to-OTF matching" and follow the instructions provided for the OTF file.

The following is an example of this section of the file:

```
# Lens-to-OTF matching. These are of the form LENS_<lensIDNumber>_OTF
# and are defined to be the file name in the OTF directory of the OTF
# that is to be used for this lens ID.
LENS_12_OTF 60X140_sample.otf
LENS_10602_OTF 60X140.otf
LENS_10003_OTF 100X135.otf
LENS_10403_OTF 40X135_sample.otf
LENS_10603_OTF 60Xw_120.otf
LENS_10205_OTF 20X0.75c.otf
```



## Appendix D. Reference Information

---

The appendix includes the following topics:

- *Standard Filename Extensions* lists the filename conventions used by DeltaVision.
- *Standard Fluorescence Filters* shows the excitation and emission peaks of the standard filters for both fixed and live cell experiments included with DeltaVision.
- *Reference List* includes references for microscopy, Linux, image processing, optics, microscopy, and sample preparation.

### Standard Filename Extensions

The following is a list of filename conventions used by DeltaVision.

<b>Filename Extension</b>	<b>Type of File</b>
*.dv	Standard DeltaVision image
*.otf	Optical Transfer Function
*_R3D.dv	Resolve3D image
*_D3D.dv	Deconvolved image
*_VOL.dv	Volume Rendered image

## Standard Fluorescence Filters

Depending on which broadband light source the system uses, the DeltaVision imaging system provides a variety of different filter sets for both fixed and live cell imaging, a polarizer, and multiple sets of optional filters. These filters are designed to be used with many common fluorescent probes. If you are using fluorescent probes that are not well matched with the standard DeltaVision filters, contact GE for assistance.

## InsightSSI Module

The 4-color Fixed InsightSSI includes four of the most common sets of filters used for fixed cell imaging.

**Table D.1 InsightSSI 4-color Fixed**

Filter Name	Excitation	Emission	Appropriate Probes
DAPI	UV, 381-401nm	Blue, 409-456nm	DAPI, Hoechst, Coumarin, Alexa 350 <sup>®</sup> , Alexa 405 <sup>®</sup>
FITC	Blue Green, 464-492nm	Green, 500-523nm	Fluorescein, GFP, Cy3, Alexa 488 <sup>®</sup>
TRITC	Yellow Green, 531-556nm	Yellow, 564-611nm	Rhodamine, Texas Red, Phycoerythrin, Alexa 568, Alexa 594 <sup>®</sup>
Cy5	Red, 619-644nm	Infrared, 652-700nm	Cy5, Alexa 647 <sup>®</sup>

The 4-color Live Cell InsightSSI includes four of the most common sets of filters used for live cell imaging.

**Table D.2 InsightSSI 4-color Live Cell**

Filter Name	Excitation	Emission	Appropriate Probes
CFP	Blue, 400-454nm	Blue Green, 463-487nm	Cyan FP (CFP)
GFP	Blue Green, 425-495nm	Green, 500-550nm	E-GFP
YFP	Green, 496-528nm	Yellow Green, 537-559nm	Yellow FP (YFP)
mCherry	Yellow, 555-590nm	Orange, 600-675nm	mCherry, tdTomato, mRFP, DsRed

The 7-color Live Cell InsightSSI includes seven of the most common sets of filters used for fixed *and* live cell imaging.

**Table D.3 InsightSSI 7-color (for Fixed and Live Cell Imaging)**

<b>Filter Name</b>	<b>Excitation</b>	<b>Emission</b>	<b>Appropriate Probes</b>
DAPI	UV, 381-401nm	Blue, 409-456nm	DAPI
CFP	Blue, 400-454nm	Blue Green, 463-487nm	CFP
FITC-GFP	Blue Green, 425-495nm	Green, 500-550nm	Fluorescein, E-GFP, Alexa 488 <sup>®</sup> , Cy3
YFP	Green, 496-528nm	Yellow Green, 537-559nm	Yellow FP (YFP)
TRITC	Yellow Green 531-556nm	Yellow 564-611nm	Texas Red, Rhodamine
mCherry	Yellow 555-590nm	Orange 600-675nm	mCherry, tdTomato, mRFP, DsRed
Cy5	Red 619-644nm	Infrared 652-700	Cy5, Alexa 647 <sup>®</sup>

## Xenon Arc Lamp

The excitation and emission peaks of the DeltaVision filters are provided in the following table.

**Table D.4 Xenon Standard Fixed Cell Filter Set**

<b>Filter Name</b>	<b>Excitation</b>	<b>Emission</b>	<b>Appropriate Probes</b>
DAPI	UV, 325-375nm	Blue, 438-478nm	DAPI, Hoechst, Coumarin, Alexa 350 <sup>®</sup> , Alexa 405 <sup>®</sup>
FITC	Blue Green, 481-502nm	Green, 506-543nm	Fluorescein, GFP, Cy3, Alexa 488 <sup>®</sup>
TRITC	Green, 547-563nm	Yellow/Orange, 576-630nm	Rhodamine, Texas Red, Phycoerythrin, Alexa 568 <sup>®</sup> , Alexa 594 <sup>®</sup>
Cy5 <sup>®</sup>	Red, 636-656nm	Infrared, 667-719nm	Cy5, Alexa 647 <sup>®</sup>

The optional Xenon Live Cell filter wheel module includes four of the most common sets of filters used for live cell imaging.

Table D.5 Xenon Live Cell Filter Set

Filter Name	Excitation	Emission	Appropriate Probes
CFP	Blue, 415-445nm	Blue Green, 455-485nm	Cyan FP (CFP)
YFP	Green, 490-510nm	Yellow Green, 520-550nm	Yellow FP (YFP)
mCherry	Yellow, 555-590nm	Orange, 600-675nm	DsRed, tdTomato, mCherry, mRFP
GFP	Blue Green, 425-495nm	Green 500-530nm	E-GFP

## Additional Reading Material

Material for further reading is available on the following pages. Contact GE for the most recent list. If you notice omissions from the list, please inform your GE representative.

### Microscopy

Agard, D. A., Sedat J. W. (1983) Three-dimensional architecture of a polytene nucleus. *Nature* 302: 676-681.

Agard, D. A. (1984) Optical Sectioning Microscopy: Cellular Architecture in Three Dimensions. *Ann. Rev. Biophys. Bioeng.* 13: 191-219.

Agard D.A., Hiraoka Y., Sedat J.W. (1988) Three-dimensional light microscopy of diploid *Drosophila* chromosomes. *Cell Motility & Cytoskeleton* 10:18-27.

Agard D.A., Hiraoka Y., Shaw P.J., Sedat J.W. (1989) Fluorescence microscopy in three dimensions. *Methods in Cell Biology* 30:353-377.

Aikens R.S., Agard D.A., Sedat J.W. (1989) Solid-state imagers for microscopy. *Methods in Cell Biology* 29:219-313.

Anderson J.T., Paddy M.R., Swanson M.S. (1993) PUB1 is a major nuclear and cytoplasmic polyadenylated RNA-binding protein in *Saccharomyces cerevisiae*. *Molecular & Cell Biology* 13:6102-6113.

Asada T., Kuriyama R., Shibaoka H. (1997) TKRP125, a kinesin-related polypeptide involved in the centrosome-independent organization of the cytokinetic apparatus of tobacco BY-2 cells. *Journal of Cell Science* 110, in press.

Babcock D.F., Herrington J., Goodwin P.C., Park Y.B., Hille B. (1997) Mitochondrial Participation in the Intracellular Ca<sup>2+</sup> Network. *Journal of Cell Biology*, in press 12/96.

Bass H.W., Marshall, W.F., Sedat J.W., Agard D.A., Cande W.Z. (1997) Telomeres cluster de novo before the initiation of synapsis: A three-dimensional spatial analysis of telomere positions before and during meiotic prophase. *Journal of Cell Biology* 137 (1):5-18.

Belmont A.S., Braunfeld M.B., Sedat J.W., Agard D.A. (1989) Large-scale chromatin domains within mitotic and interphase chromosomes in vivo and in vitro. *Chromosoma* 98:129-143.

Belmont A.S., Sedat J.W., Agard D.A. (1987) A three-dimensional approach to mitotic chromosome structure: evidence for a complex hierarchical organization. *Journal of Cell Biology* 105:77-92.

- Belmont A.S. and K. Bruce. (1994) Visualization of G1 chromosomes: a folded, twisted, supercoiled chromonema model of interphase chromatid structure. *Journal of Cell Biology* 127: 287-302.
- Charlton C.A., Mohler W.A., Radice G.L., Hynes R.O., Blau H.M. (1997) Fusion Competence of Myoblasts Rendered Genetically Null for N-Cadherin in Culture. *Journal of Cell Biology* 138: 331-336.
- Chen H., Sedat J.W., Agard D.A. (1989) Manipulation, display, and analysis of three-dimensional biological images, in *Handbook of Biological Confocal Microscopy* (Pawley J, ed.) pp. 127-135. IMP Press, Madison, WI.
- Chen H., Hughes D.D., Chan T.-A., Sedat J.W., Agard D.A. (1996) IVE (Image Visualization Environment): A Software Platform for All Three-Dimensional Microscopy Applications. *Journal of Structural Biology* 116: 56-60.
- Chikashige Y., Ding D.Q., Funabuki H., Haraguchi T., Mashiko S., Yanagida M., Hiraoka Y. (1994) Telomere-led premeiotic chromosome movement in fission yeast. *Science* 3:270-273.
- Cooke C.A., Schaar B., Yen T.J., Earnshaw W.C. (1997). Localization of CENP-E in the fibrous corona and outer plate of mammalian kinetochores from prometaphase through anaphase. *Chromosoma Berl.* 106: 446-455. (cover article)
- Csink A.K., Henikoff S. (1996) Genetic modification of heterochromatic association and nuclear organization of *Drosophila*. *Nature* 381: 529-531.
- Dawe R.K., Sedat J.W., Agard D.A., Cande, W.Z. (1994). Meiotic chromosome pairing in maize is associated with a novel chromatin organization. *Cell* 76: 901-912.
- Dawe R.K., Cande W.Z. (1996) Induction of centromeric activity in maize by *suppressor of meiotic drive 1*. *PNAS, USA* 93:8512-8517.
- Dernburg A.F., Daily D.R., Yook K.J., Corbin J.A., Sedat J.W., Sullivan W. (1996) Selective loss of sperm bearing a compound chromosome in the *Drosophila* female. *Genetics* 143: 1629-1642.
- Dernburg A.F., Sedat J.W., Hawley R.S. (1996) Direct evidence of a role for heterochromatin in meiotic chromosome segregation. *Cell* 86: 135-146.
- Dernburg A.F., Broman K.W., Func J.C., Marshall W.F., Agard D.A., Sedat J.W. (1996) Perturbation of nuclear architecture by long-distance chromosome interactions. *Cell* 85: 745-759.
- Gertler F.B., Niebuhr K., Reinhard M., Wehland J., Soriano P. (1996) Mena, a Relative of VASP and *Drosophila* Enabled, Is Implicated in the Control of Microfilament Dynamics. *Cell* 87: 227-239.
- Goodwin P.C. (1996) Wide-Field Deconvolution vs. Confocal Microscopy of Living Cells. *Scanning* 18,3:144-145.
- Hartley W.J. *How to Use a Microscope*. Doubleday, 1964.
- Herman B., Jacobson K., ed. *Optical Microscopy for Biology*. Wiley-Liss, New York NY, 1980.
- Hiraoka Y., Agard D.A., Sedat J.W. (1991) Temporal and spatial coordination of chromosome movement, spindle formation and nuclear envelope breakdown during prometaphase in *Drosophila melanogaster* embryos. *Journal of Cell Biology* 111:2815-2828. (cover article)

- Hiraoka Y., Dernburg A.F., Parmalee S.J., Rykowski M.C., Agard D.A., Sedat J.W. (1991) The onset of homologous chromosome pairing during *Drosophila melanogaster* embryogenesis. *Journal of Cell Biology* 120:591-600. (cover article)
- Hiraoka Y., Haraguchi T. (1996) Fluorescence imaging of mammalian living cells. *Chromosome Research* 4,3: 173-176.
- Hiraoka Y., Minden J.S., Swedlow J.R., Sedat J.W., Agard D.A. (1989) Focal points for chromosome condensation and decondensation from three-dimensional in vivo time-lapse microscopy. *Nature* 342:293-296.
- Hiraoka Y., Rykowski M.R., Lefstin J.A., Agard D.A., Sedat J.W. (1990) Three-dimensional organization of chromosomes studied by in situ hybridization and optical sectioning microscopy. *Proc Soc Photo-electro Instrument Engin* 1205:11-19.
- Hiraoka Y., Sedat J.W., Agard D.A. (1987) The use of a charge coupled device for quantitative optical microscopy of biological structures. *Science* 238:36-41.
- Hiraoka Y., Sedat J.W., Agard D.A. (1990) Determination of three-dimensional imaging properties of a light microscope system: partial confocal behavior in epifluorescence microscopy. *Biophysical Journal* 57:325-333.
- Hiraoka Y., Swedlow J.R., Paddy M.R., Agard D.A., Sedat J.W. (1991) Three-dimensional multiple wavelength fluorescence microscopy for the structural analysis of biological phenomena. *Seminars in Cell Biology* 2:153-165.
- Hochstrasser M., Sedat J.W. (1987) Three-dimensional organization of *Drosophila melanogaster* interphase nuclei. I. Tissue-specific aspects of polytene nuclear architecture. *Journal of Cell Biology* 104:1455-70.
- Hochstrasser M., Sedat J.W. (1987) Three-dimensional organization of *Drosophila melanogaster* interphase nuclei. II. Chromosome spatial organization and gene regulation. *Journal of Cell Biology* 104:1471-83.
- Ikeya T., Shinohara A., Sato S., Tabata S., Ogawa T. (1996) Localization of mouse Rad51 and Lim15 proteins on meiotic chromosomes at late stages of prophase 1. *Genes To Cells* 1:379-389.
- Inoue S. *Video Microscopy*. Prenum Press, New York NY, 1986.
- Jongens T.A., Ackerman L.D., Swedlow J.R., Jan L.Y., Jan Y.N., (1994) *Germ cell-less* functions early in the germ cell specification pathway of *Drosophila*. *Genes Devel* 8:2123-2136.
- Kam Z., Agard D.A., Sedat J.W. (1997) Three-dimensional microscopy in thick biological samples: a fresh approach for adjusting focus and correcting spherical aberration. *Bioimaging* 5:40-49.
- Kam Z., Chen H., Sedat J.W., Agard D.A. (1991) Analysis of three-dimensional image data: display and feature tracking, in *Electron Tomography* (Frank J, ed.) Plenum Press, New York.
- Kam Z., Jones M.O., Chen H., Agard D.A., Sedat J.W. (1993) Design and construction of an optimal illumination system for quantitative wide-field multidimensional microscopy. *Bioimaging* 1:71-81.
- Kam Z., Minden J.S., Agard D.A., Sedat J.W., Leptin M. (1991) *Drosophila* gastrulation: analysis of cell shape changes in living embryos by three-dimensional fluorescence microscopy. *Development* 112:365-70.
- Kam Z., Volberg T., Geiger B. (1995) Mapping of adherens junction components using microscopic resonance energy transfer imaging. *Journal of Cell Science* 108:1051-1062.

- Kaplan K.B., Swedlow J.S., Varmus H.E., Morgan D.O. (1992) Association of p60<sup>c-src</sup> with endosomal membranes in mammalian fibroblasts. *Journal of Cell Biology* 118:321-33. (cover article)
- Kaplan K.B., Bibbins K.B., Swedlow J.R., Arnaud M., Morgan D.O., Varmus H.E. (1994) Association of the amino terminal half of c-Src with focal adhesions alters their properties and is regulated by phosphorylation of tyrosine 527. *EMBO Journal* 13:4745-4756.
- Kaplan K.B., Swedlow J.R., Morgan D.O., Varmus H.E. (1995) c-Src enhances the spreading of src<sup>-/-</sup> fibroblasts on fibronectin by a kinase-independent mechanism. *Genes Devel* 9:1505-1517.
- Kirk K.E., Harmon B.P., Reichardt I.K., Sedat J.W., Blackburn E.H. (1997) Block in Anaphase Chromosome Separation Caused by Telomerase Template Mutation. *Science* 275: 1478-1481.
- Lauer S. A., P. K. Rathod, N. Ghori, K. Haldar (1997) A Membrane Network for Nutrient Import in Red Cells Infected with the Malaria Parasite. *Science* 276.
- Lieb J. D., Capowski E. E., Meneely P., Meyer B. J. (1996) DP-Y, a Link Between Dosage Compensation and Meiotic Chromosome Segregation in the Nematode. *Science* 274: 1732-1736.
- Ma X, Ehrhardt D. W., Margolin W. (1996) Colocalization of cell division proteins FtsZ and FtsA to cytoskeletal structures in living Escherichia coli cells by using green fluorescent protein. *PNAS USA*, 93: 12998-13003.
- Marshall W.F., Dernburg A.F., Harmon B., Agard D.A., Sedat J.W. (1996) Specific interactions of chromatin with the nuclear envelope: Positional determination within the nucleus in *Drosophila melanogaster*. *Molecular Biology of the Cell*, 7: 825-842.
- Marshall W.F., Fung J.C., Sedat J.W. (1997) Deconstructing the nucleus: Global architecture from local interactions. *Current Opinion in Genetics & Development*, 7: 259-263.
- Marshall W.F., Straight A., Marko J.F., Swedlow J.R., Dernburg A., Belmont A., Murray A.W., Agard D.A., Sedat J.W. (1997) Interphase chromosomes undergo constrained diffusional motion in living cells. *Curr. Biol.* 7:930-939.
- Mathog D., Sedat J.W. (1989) The three-dimensional organization of polytene nuclei in male *Drosophila melanogaster* with compound XY or ring X chromosomes. *Genetics* 121:293-311.
- Minden J.S., Agard D.A., Sedat J.W., Alberts B.M. (1989) Direct cell lineage analysis in *Drosophila melanogaster* by time-lapse, three-dimensional optical microscopy of living embryos. *Journal of Cell Biology* 109:505-516. (cover article)
- Moritz M., Braunfeld M.B., Sedat J.W., Alberts B., Agard D.A. (1995) Microtubule nucleation by gamma-tubulin-containing rings in the centrosome. *Nature* 378 (6557): 638-640.
- Moritz M., Braunfeld M.B., Fung J.C., Sedat J.W., Alberts B.M, Agard D.A. (1995) Three-dimensional structural characterization of centrosomes from early *Drosophila* embryos. *Journal of Cell Biology* 130: 1149-1159.
- Näthke I.S., Hinck L., Swedlow J.R., Papkoff J., Nelson W.J. (1994) Defining interactions and distributions of cadherin and catenin complexes in polarized epithelial cells. *Journal of Cell Biology* 125:1341-1352.
- Näthke I.S., Adams C.L., Polakis P., Sellin J.H., Nelson W.J. (1996) The adenomatous polyposis coli tumor suppressor protein localizes to plasma membrane sites involved in active cell migration. *Journal of Cell Biology* 134:165-179. (cover article)

- Neugebauer K.M., Roth M.B. (1997) Distribution of pre-mRNA splicing factors at sites of RNA polymerase II transcription. *Genes and Development* 11:1148-1159.
- Paddy M.R. (1998) Determining Nuclear Structure Using the Fluorescence Light Microscope. *Methods in Cell Biology* 53: 49-77.
- Paddy M.R., Agard D.A., Sedat J.W. (1992) An extended view of nuclear lamin structure, function, and dynamics. *Seminars in Cell Biology* 3:255-266.
- Paddy M.R., Belmont A.S., Saumweber H., Agard D.A., Sedat J.W. (1990) Interphase nuclear envelope lamins form a discontinuous network that interacts with only a fraction of the chromatin in the nuclear periphery. *Cell* 62:89-106.
- Paddy M.R., Chelsky D. (1991) Spoke: a 120-kD protein associated with a novel filamentous structure on or near kinetochore microtubules in the mitotic spindle. *Journal of Cell Biology* 113:161-171.
- Paddy M.R., Saumweber H., Agard D.A., Sedat J.W. (1996) Time-resolved, *in-vivo* studies of mitotic spindle formation and nuclear lamina breakdown in *Drosophila* early embryos. *Journal of Cell Science* 109: 591-607.
- Periasamy, A., Day R.N. (1997) PIT-1 protein localization at different optical sections in a single living cell using FRET microscopy and green fluorescent proteins. *Microscopy & Microanalysis*, submitted for publication.
- Periasamy A. (1998) Digital Deconvolution FRET Microscopy: 3D Visualization of Protein-Protein Interactions in a Single Living Cell (Invited Paper). *SPIE* 3260: 1-9.
- Rossi F., Charlton C.A., and Blau H. M. (1997) Monitoring protein-protein interactions in intact eukaryotic cells by beta  $\gamma$ -galactosidase complementation. *PNAS USA*, 94: 8405-8510.
- Rykowski M.C., Parmelee S.J., Agard D.A., Sedat J.W. (1988) Precise determination of the molecular limits of a polytene chromosome band: regulatory sequences for the Notch gene are in the interband. *Cell* 54:461-472.
- Scalettar B.A., Swedlow J.R., Sedat J.W., Agard D.A. (1996) Dispersion, aberration, and deconvolution in multi-wavelength fluorescence images. *Journal of Microscopy* 182: 50-60.
- Schwartz K., Richards K, Botstein D. (1997) *BIM1* encodes a a microtubule-binding protein in yeast. *Molecular Biology of the Cell* 8: 2677-2691.
- Segal E.D., Lange C., Covacci A., Tompkins L.S., Falkow S. (1997) Induction of host signal transduction pathways by *Helicobacter pylori*. *PNAS USA*, 94: 7595-7599.
- Shaw P. (1994) Deconvolution in 3-D optical microscopy. *Histochemical Journal* 26: 687-694.
- Shaw P.J., Agard D.A., Hiraoka Y., Sedat J.W. (1988) Tilted view reconstruction in optical microscopy: Three-dimensional reconstruction of *Drosophila melanogaster* embryo nuclei. *Biophysical Journal* 55:101-110.
- Shimanuki M., Miki F., Ding D.-Q., Chikashige Y., Hiraoka Y., Horio T., Niwa O. (1997) A novel fission yeast gene, *kms1<sup>+</sup>*, is required for the formation of meiotic prophase-specific nuclear architecture. *Molecular and General Genetics* 254: 238-249.
- Stevenson, R. (1996) Bioapplications and instrumentation for light microscopy in the 1990s. *American Laboratory* April 1996.



- Straight, A.F, Marshall W.F., Sedat J.W., Murray A.W. (1997) Mitosis in living budding yeast: Anaphase A but no metaphase plate. *Science* 277:574-578.
- Sullivan W., Minden J.S., Alberts B.M. (1990) *daughterless-abolike*, a Drosophila maternal-effect mutation that exhibits abnormal centrosome separation during the late blastoderm divisions. *Development* 110:311-323.
- Swedlow J.R., Agard D.A., Sedat J.W. (1993) Chromosome structure inside the nucleus. *Current Opinions in Cell Biology* 5:412-416.
- Swedlow J.R., Hirano T. (1996) Chromosome dynamics: Fuzzy sequences, specific attachments? *Current Biology* 6: 544-547.
- Swedlow J.R., Sedat J.W., Agard D.A. (1993) Multiple chromosomal populations of topoisomerase II detected in vivo by time-lapse, three-dimensional wide-field microscopy. *Cell* 73: 97-108.
- Swedlow J.R., Sedat J.W., Agard D.A. (1997) Deconvolution in optical microscopy. Deconvolution of images and spectra , 2nd Edition. PA Jansson, ed. Academic Press, NY. pp. 284-309.
- Takizawa P.A., Sil A., Swedlow J.R., Herskowitz I., Vale R.D. (1997) Actin-dependent localization of an RNA encoding a cell-fate determinant in yeast. *Nature* 389: 90-93.
- Tempel B., Wang H., Goodwin P.C. (1996). *BioTechniques* 20: cover image. Winner of "1996 BioTechniques Cover Photo Contest".
- Urata Y., Parmalee S.J., Agard D.A., Sedat J.W. (1995) A three-dimensional structural dissection of Drosophila polytene chromosomes. *Journal of Cell Biology* 131: 279-95.
- Van Wye J., Ghorri N., Webster P., Mitschler R.R., Elmendorf H.G., Haldar K. (1996) Identification and localization of rab6, separation of rab6 from ERD2 and implications for an 'unstacked' Golgi, in Plasmodium falciparum. *Molecular and Biochemical Parasitology* 83: 107-120.
- Vodicka M.A., Koepp D.M., Silver P.A., Emerman M. (1998) HIV-1 Vpr interacts with the nuclear transport pathway to promote macrophage infection. *Genes & Development* 12: 175-185. (cover article)
- Waters D., Brown C. (1996) New high-resolution 3-D microscope avoids damage to live samples. *Biophotonics International* 3: 40-44. (cover article)
- Welnhofner E.A., Zhao L., Cohan C.S. (1997) Actin Dynamics and Organization During Growth Cone Morphogenesis in Helisoma Neuron. *Cell Motility and the Cytoskeleton* 37: 54-71. (cover article)
- Wilson S.M., Datar K.V., Paddy M.R., Swedlow J.R., Swanson M.S. (1994) Characterization of nuclear polyadenylated RNA-binding proteins in Saccharomyces cerevisiae. *Journal of Cell Biology* 127:1173-1184.
- Zimowska G., Aris J.P., Paddy M.R. (1997) A Drosophila Tpr protein homolog is localized both in the extrachromosomal channel network and to nuclear pore complexes. *Journal of Cell Science* 110: 927-944.

## Linux Operating System

Siever, Ellen. *Linux in a Nutshell, Third Edition*. O'Reilly and Associates, 2001.

## Image Processing

Bracewell R.N. *The Fourier Transform and Its Applications*. 2nd Edition, McGraw Hill, New York NY, 1986.

Goodman J.W. *Introduction to Fourier Optics*. McGraw-Hill, New York NY, 1968.

Castleman K.R. *Digital Image Processing*. Prentice-Hall, Englewood Cliffs NJ, 1979.

Gonzales R.C., Wintz P. *Digital Image Processing, 2nd Ed.* Addison-Wesley, Reading MA., 1987.

Pratt W.K. *Digital Image Processing*. Wiley, New York NY, 1991.

Russ J.C. *The Image Processing Handbook*. CRC Press, Boca Raton FL, 1992.

## Optics

Born M., Wolf E. *Principles of Optics*. Pergamon, Oxford, 1970.

Hecht E. *Optics*. Addison Wesley, Reading MA, 1987.

Hopkins H.H. (1955) The frequency response of a defocused optical system. *Proc. Royal Society A*, 231: 91-103.

Jenkins F.A., White H.E.. *Fundamentals of Optics*. McGraw-Hill, New York NY, 1976.

Streibl N. (1985) Three-dimensional imaging by a microscope. *Journal of the Optical Society of America A*, 2: 121-127.

## Appendix E. Resolve3D & Keypad Use

---

This chapter describes the following:

- *The Resolve3D Window* is the main window for data acquisition.
- *The Design/Run Experiment Window* provides tools to select, design, edit, and execute experiment macros.
- *The Settings Window* used to control how images are displayed, select camera settings, and specify file output.
- *Keypad/Joystick Operation* is a reference for the buttons on the keypad. Many of the Resolve3D functions are also available on the keypad and joystick.

### The Resolve3D Window

The Resolve3D window is the main data acquisition window. In addition to providing many of the acquisition options and controls, it provides access to the other windows that are used for data acquisition.

#### To open Resolve3D:

- From the softWoRx menu, choose **File | Acquire (Resolve3D)**. The Resolve3D window is displayed.

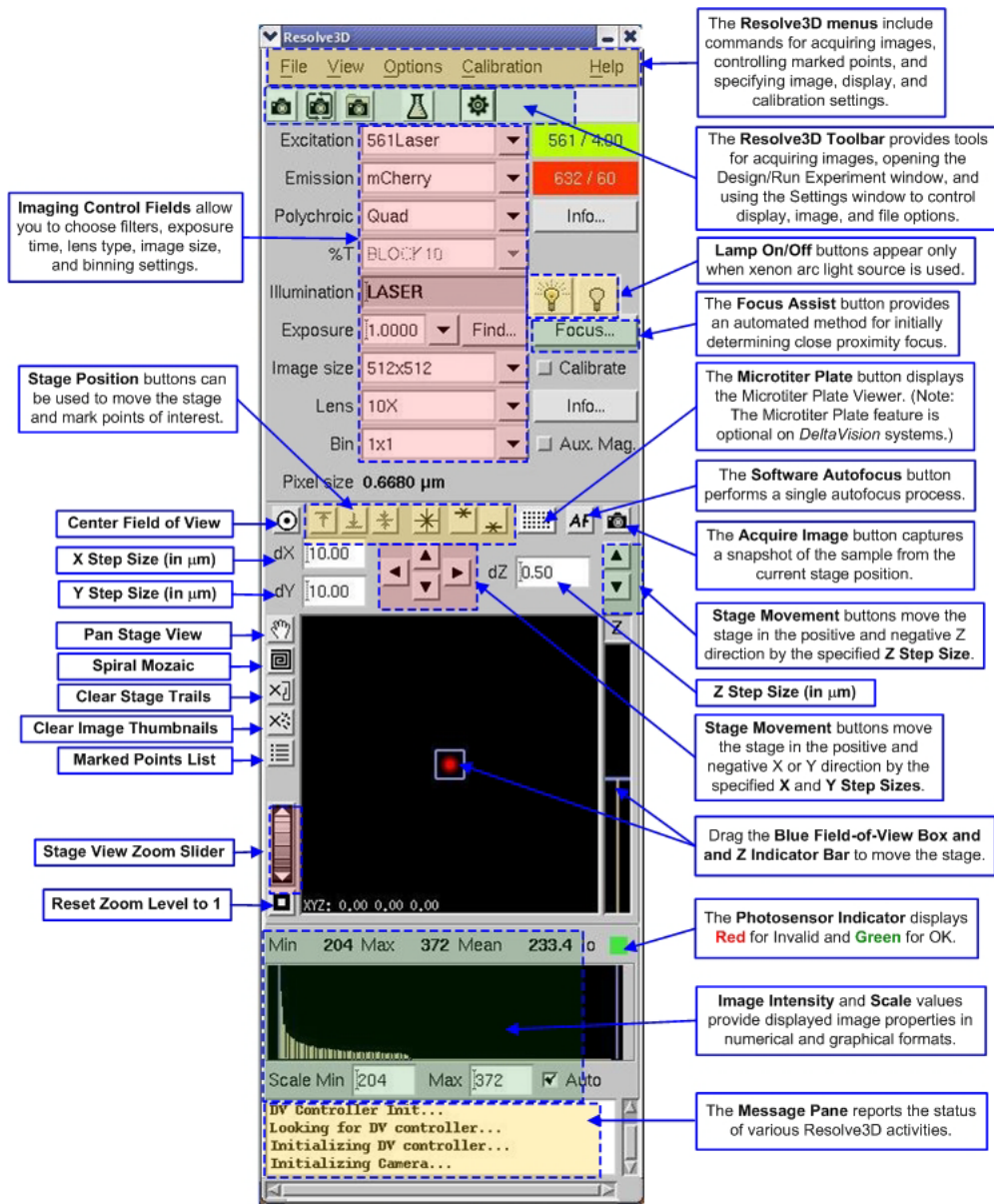

## The Resolve3D Menu

The Resolve3D menu contains the following submenus:

- **The File menu** includes commands to acquire images and to open the key windows for setting up and running experiments.
- **The View menu** includes commands to manage marked points and to create a blank screen.
- **The Options menu** includes commands to open the Settings window (where you can set display and image options) and to save settings.
- **The Calibration menu** opens the Calibration tool.

- **The Help menu** provides options to show or hide ToolTips and to get Help.

### The Resolve3D File Menu

Use the following Resolve3D File menu commands to acquire images, create scratch files, and open the Design/Run Experiment window.

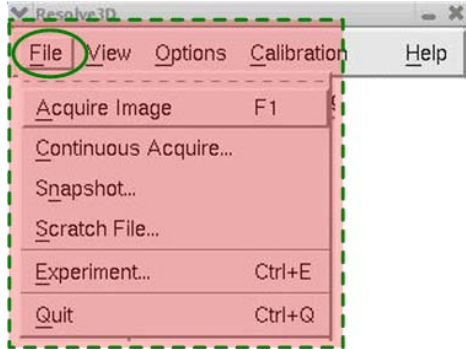

**The Resolve3D File Menu**

### Acquire Image

Collects and displays an image from the microscope. This image is only displayed in the Data Collection window. It is not saved to a disk file for later use.

### Continuous Acquire

Opens the Continuous Acquire window that you can use to collect and display images continuously. These images are only displayed; they are not saved to a disk file.

### Snapshot

Launches a tool to let you collect a single 2-D, multi-wavelength "snapshot" image. If you need to collect a Z series, time-lapse image, or other complex scheme, you will need to design an experiment with the Resolve3D Experiment Designer. You can also do an OAI as part of your snapshot.

### Scratch File

Creates a "scratch file" to which you can save individual image frames for later use. After a file is opened, clicking **Save Current Image** saves the most recently collected image frame. Clicking **Close Scratch File** or **Done** closes the file. Note that the image size cannot be changed while a scratch file is open.

### Experiment

Opens the Design/Run Experiment window. You can use Design/Run Experiment to select a previously created experiment, to design a new experiment, or to open the Experiment Macro Editor to create or edit an experiment macro.

### Quit

Closes the Resolve3D window.

### The Resolve3D View Menu

Use the View menu to manage points that you have marked, to clear the history of the path that you took while exploring your sample, or to create a black screen for light-sensitive conditions.

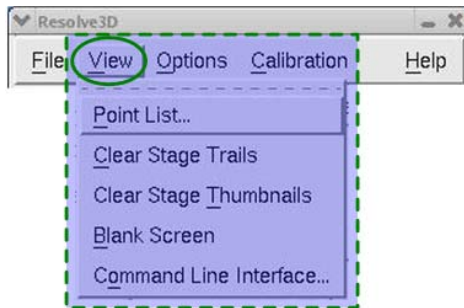

The Resolve3D View Menu

### Point List

Opens the Points List window. This window helps you manage a list of points (with X, Y, and Z coordinates) that you want the system to remember. These points can be interactively "visited" at any time and they can be used in experiments.

### Clear Stage Trails

Clears the Stage Trails history. (The system maintains a history of the paths of motion that you take while exploring your sample. These paths are displayed as "Stage Trails" on the Stage View.)

### Clear Stage Thumbnails

Clears all of the thumbnail images currently displayed on the Stage View.

### Blank Screen

Turns the computer screen blank. This is useful when you are imaging under very light-sensitive conditions. Clicking anywhere on the screen restores it.

### Command Line Interface

Opens the Command Line window that provides advanced users with the ability to issue individual Resolve3D commands to the system.



**CAUTION!** The Command Line Interface should be used carefully because it can put the system in an unstable state.

### The Resolve3D Options Menu

Use the Options menu to open the Settings window (where you can set display and image options) and to save configuration settings and state information.

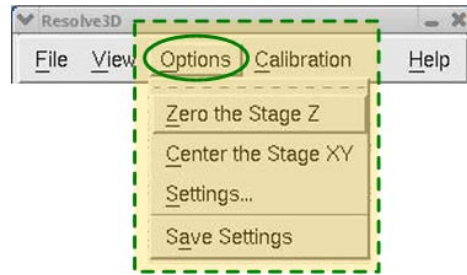

**The Resolve3D Options Menu**

### **Zero the Stage Z**

Selecting **Zero the Stage Z** from the Options menu provides a protocol for moving the stage in the Z direction to the middle of its working range.

### **Center the Stage XY**

Selecting the Center the Stage XY from the Options menu provides a protocol for moving the stage in the XY direction to the middle of its working range.

### **Settings**

Opens the Settings window which allows you to control display, imaging, and file output options.

### **Save Settings**

Saves the configuration settings and information (current filters, image size, etc.) to be used the next time Resolve3D is opened.

### **The Resolve3D Calibration Menu**

Use the Calibration menu to make calibration tables, read calibration tables, and designate which calibration tables are active.

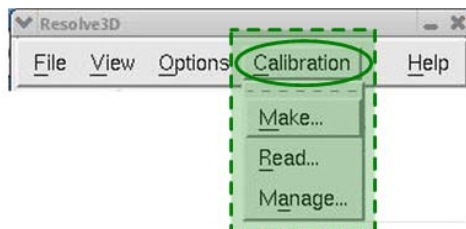

**The Resolve3D Calibration Menu**

### **Make**

Opens the Calibration tool used to create flat-field calibration tables and optional tables of "bad" pixels. These tables may be applied to images, either when they are acquired or at a later time. (To apply the tables to images after they are acquired, use the Calibrate utility available from the Process item on the main *softWoRx* menu.)

### Read

Opens the Read Calibration Files window that you can use to read calibration tables.

### Manage

Opens the Manage tool that you can use to designate which calibration tables are active and to remove tables from the system's session memory.

### The Resolve3D Help Menu

Use this menu to turn ToolTips on or off, get help on the Resolve3D window, or find out which version of *softWoRx* you are using.

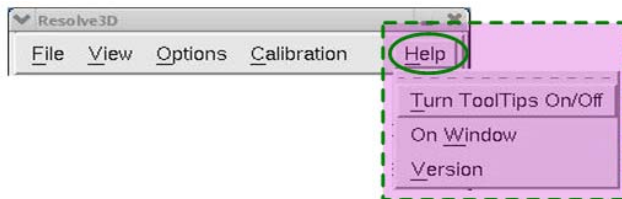

The Resolve3D Help Menu

### Turn ToolTips On/Off

Turns tool tips on or off. Tool tips display “pop-up” information about buttons on the interface. They open when the mouse pointer is held over a button for a few seconds.

### On Window

Opens Help for the Resolve3D window.

### Version

Displays version numbers for the *softWoRx* components.

### The Resolve3D Toolbar

Use the buttons on the Resolve3D toolbar to acquire images, open the Experiment Designer/Run window that allows you to set up and run experiments, and open the Settings window that allows you to control display, imaging, and file output options.

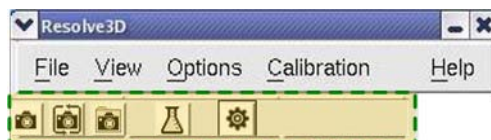

The Resolve3D Toolbar

### Acquire

Collects and displays an image from the microscope with the current settings. This image is only displayed in the Data Collection window. It is not saved in a file.

### Continuous Acquire



## Snapshot

### Experiment

Opens the Design/Run Experiment window that you can use to select a previously created experiment, to design a new experiment, or to open the Experiment Macro Editor to create or edit an experiment macro.

### Settings

Opens the Settings window that allows you to control display, imaging, and file output options.

### Image Control Fields

Use the Resolve3D Image Control fields to:

- Select the Excitation, Emission, and Neutral Density (%T) filters.
- Select exposure time.
- Determine whether to calibrate the image.
- Select the desired shutter.
- Select the image size.
- Select the lens and get lens information, including the oil calculation.
- Select whether auxiliary magnification is used.
- Determine binning parameters.
- Get pixel size.
- Select the polychroic.

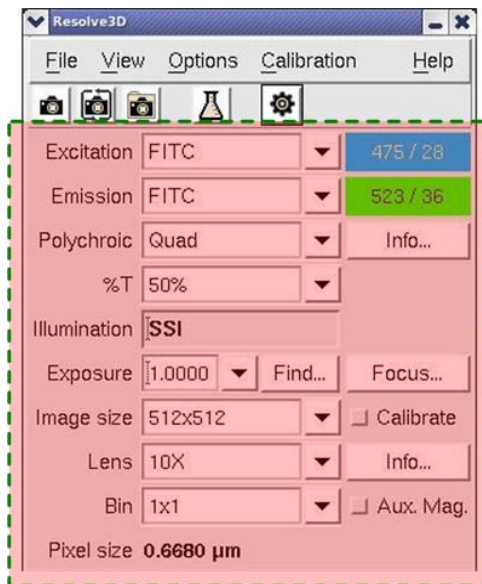

**The Resolve3D Image Control Fields**

### **Excitation**

Specifies an excitation channel. When this field is changed, the following parameters are set to the last values that were used for that excitation channel.

- Emission filter
- Exposure time
- Neutral Density value (%T)
- Active illumination shutters
- Number of frames to average
- Target intensity

You can choose **Save Settings** from the Options menu to store the configuration. The wavelength/bandwidth of the selected filter is indicated to the right of the filter choice box.

### **Emission**

Specifies an emission filter. The wavelength/bandwidth of the selected filter is indicated to the right of the filter choice box.

### **Polychroic**

Specifies a polychroic to place into the active position of a motorized polychroic turret. If a motorized turret is not present, this is a display-only field and will not affect anything during imaging. The selections available are displayed in the drop-down list in this field. Your choices will completely depend upon which polychroic filters are installed on your system.

### **Illumination**

Indicates which light source will be used. This field is filled in automatically with the primary light source used on your system. The indicators are as follows:

- **SSI** - for all broadband illumination.
- **TRANS** - for transmitted light.
- **LASER** - for laser light.

### **%T**

Specifies a Neutral Density value. The relative illumination intensity is indicated in the menu.

### **Exposure**

Specifies camera exposure time (in seconds). The minimum and maximum exposure times allowed for this field depend upon the camera type.

### **Find**

Opens the Target Intensity window which allows you to find the exposure time necessary to reach a Max Intensity near the Target Intensity Value. For dim samples, 300-900 counts are acceptable. For bright samples, 200-2500 counts (12-bit camera)

provide a high dynamic range without saturation. This tool is not recommended for use with live cells.

### **Calibrate**

Calibrates images when they are collected from the camera. If you use this option, you must load and activate a calibration table that fits the current imaging parameters (wavelength, image size, objective, bin choice) before you acquire images.

### **Image Size**

Specifies image size (pixels or CCD detector elements) for acquired images. The pull-down list contains predefined sizes for convenience. You can enter special sizes by choosing **Other...** from the pull-down list. (Image size must be a multiple of four.)

### **Lens**

Specifies the objective lens name. The pull-down list contains the lenses that are known to be part of the microscope system.

### **Info**

Opens the Lens Information window which displays information about the current objective lens, including the oil calculator.

### **Bin**

Specifies the number of CCD detector elements to add together to form one image element. Binning is applied in both the X and Y directions. It increases intensity, but it decreases resolution. Pixel size is a function of binning.

### **Aux. Mag.**

Specifies whether the microscope's 1.6x manual auxiliary magnification is in use. (On IX70 stands, the manual auxiliary magnification is 1.5x. For EMCCD camera systems, the auxiliary magnification is 2.0x.)

### **Pixel size**

Displays pixel dimensions in microns/pixel. The value is calculated from the Lens, Bin, and Auxiliary magnification settings.

## **Stage Position Control Fields and Buttons**

The Resolve3D Stage Position Control area allows you to control the microscope's X, Y, and Z stage positions. The Center, Mark, and Visit tools and the Stage Motion Controls are shown below.

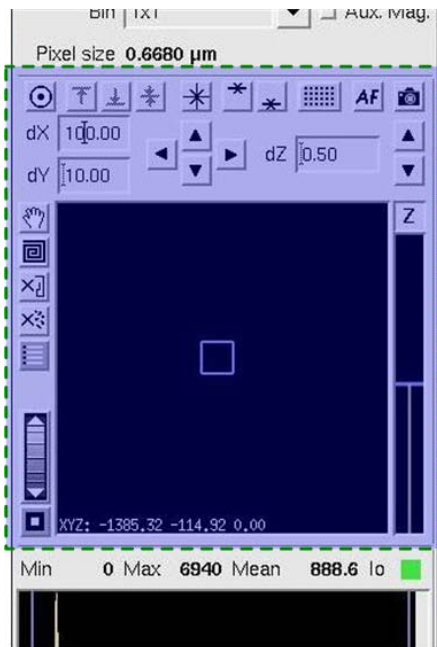

The Resolve3D Stage Position Controls

## Stage Control and Display Tools



### **Center Object**

Centers the stage on an object selected in an Image Window. The pixel size must be correct in order for object centering to work properly, which means that the correct lens and auxiliary magnification setting must be selected. An image will be acquired after the object is centered.



### **Mark Point**

Marks the current X, Y, and Z stage coordinates as points to be visited later.



### **Mark Top of Sample**

Marks the current stage Z position as the "top" of your sample. Because the scanning process always moves the stage toward the objective, this position also represents the point where the stage is closest to the objective (the most negative Z value). This also represents the focal plane that is the closest to the slide side of a sample. Use this

along with the **Mark Bottom of Sample** button to establish the thickness of the sample. You can use these marked positions to aid with the Z sectioning setup.



**Note** All scans that are set up using the Experiment Designer scan in Z, using *relative* coordinates. The **Mark Top of Sample** and **Mark Bottom of Sample** buttons are most helpful in determining the thickness of the sample to be scanned. When an experiment is started, the scan region is determined by the current focus point and the thickness of the sample. So, for example, if you have marked three points to visit in an experiment and they all have different middle-Z positions, the experiment will calculate the scan based on these different Z positions and the fixed thickness.



### **Mark Bottom of Sample (end of scan)**

Marks the current stage Z position as the "bottom" of your sample for a potential scan. This corresponds to the positive stage Z coordinate value or the coverslip side of the sample.



### **Visit Top**

Moves the stage to the position marked as the top of the sample.



### **Visit Bottom**

Moves the stage to the position marked as the bottom of the sample.



### **Visit Middle**

Visits the point in the middle of the defined scan region.



### **Plate Viewer**

Displays the Microtiter Plate Viewer window. You must have the microtiter stage option installed on your DeltaVision system in order to scan microtiter plates.



### **Autofocus**

Automatically focuses using a contrast-based software method.



### **Acquire Image**

Collects and displays an image from the microscope. The current Resolve3D image control settings are used to collect the image. This image is only displayed in the Data Collection window. It is not saved in a file for later use.



### **XY Stage Controls**

Moves the stage in the X and Y axis. The left and right arrows move the stage in the X axis in the increment set in the **dX** field and the up and down arrows move it in the Y direction in the increment set in the **dY** field.



### Z stage Motion Controls

Moves the stage in the Z axis in the increment set in the **dZ** field.

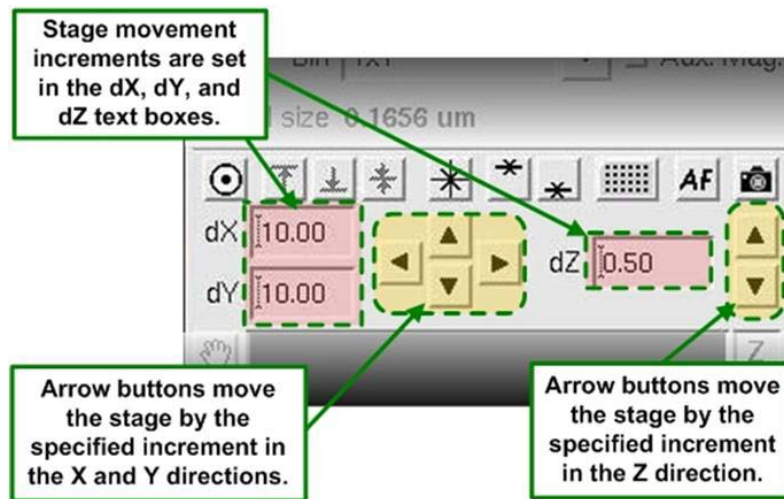

Stage Movement Controls



### Pan

Places the stage view in Pan mode. Click and drag the current view to pan it. Note that this tool is "sticky." To disable Pan mode, click the **Pan** tool again.



### Spiral Mosaic

Starts a preview collection pattern centered on the current stage location and using the active Resolve3D wavelengths. The pattern begins with the current stage location and then continues acquiring thumbnail images directly adjacent to it, spiraling outward in a counter-clockwise rotation so that the entire area centered around the initial stage position is previewed in the Resolve3D stage view. Thumbnail collection continues until either the preset spiral mosaic size (set in **Resolve3D | Settings | Misc** tab) is reached or you click the **Spiral Mosaic** button again. The stage is always returned to the initial position regardless of how the collection ends.



### Clear Stage Trails

Clears all of the stage trail lines from the stage view.



### Clear Thumbnails

Clears all of the thumbnail images currently displayed on the stage view.



### Marked Points list

Opens the Point List window to manage the list of marked points.



### Zoom Tool

Controls zoom of the stage view. Drag the thumb wheel down to zoom in; up to zoom out. The button under the thumb wheel resets the zoom to 1:1.



### Z Slider

Moves the stage up or down. Click and drag the blue horizontal bar to move a maximum of 5 $\mu$ m.

### dX

Specifies the X step size, in microns.

### dY

Specifies the Y step size, in microns.

### dZ

Specifies the Z step size, in microns.

## Stage View Window

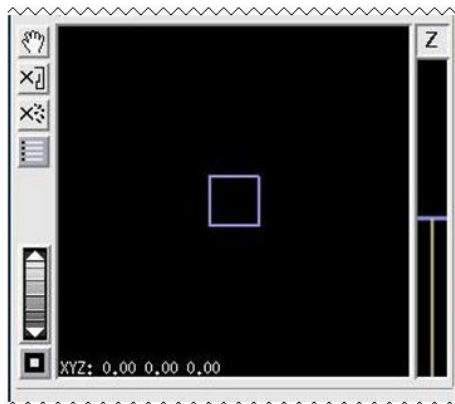

The blue box represents the current stage location. Drag the box to move the stage in X and Y.

## Image Intensity and Scale Values

The Resolve3D image intensity and scale show the intensity values of the data collection window in numerical and graphical formats. The scale of the image is also shown.

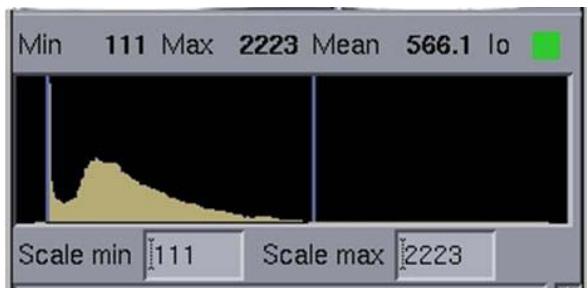

The Resolve3D Image Intensity and Scale View

### Min, Max, Mean

Displays the minimum, maximum, and mean intensity values of the most recently acquired image. For a 12 bit CCD camera, these values range between 0 and 4095. A value of 4095 indicates camera saturation, unless image calibration is in effect. (If you are using 0.5X Gain, the saturation is less than 4095 counts.)

### lo

Indicates valid (or invalid) photo sensor values or saturation. The indicator is green if the photo sensor value is valid. It is red before the first image is acquired. After the first scan, a red color indicates that the most recently acquired image has an invalid photo sensor value. A red indicator can also signify unreasonable saturation or an improperly functioning photo sensor device.

### Histogram

Shows the intensity distribution for the most recently acquired image. The vertical blue bars indicate the **Scale min** and **Scale max** and can be dragged interactively with the mouse to change how the data collection window display is scaled. The X-axis represents intensity and the Y-axis represents the number of pixels.

### Scale Min/Max

Specifies the settings for the minimum and maximum display values. These numbers can be changed manually or by moving the histogram threshold bars.

## The Message Pane

The Resolve3D Message pane reports the status of various Resolve3D activities. Use the scroll-bar to view messages that have scrolled off the top of the pane.

## Resolve3D Shortcuts

You can right-click anywhere in the Resolve3D window to open a shortcut menu that allows you to acquire images, mark points, and create a blank screen (for imaging under very light-sensitive conditions).



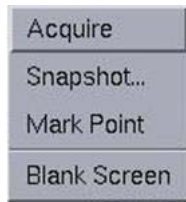

#### Resolve3D Shortcut Menu

#### Acquire

Collects and displays an image from the microscope. The current settings are used to collect the image. This image is only displayed in the Data Collection window. It is not saved in a file for later use.

#### Snapshot

Launches a tool to let you collect a single 2-D, multi-wavelength "Snapshot" image. (The current settings are used to collect the image.)

#### Mark point

Marks the current X, Y, and Z stage coordinates as a point to be visited later.

#### Blank Screen

Turns the computer screen black for imaging under very light-sensitive conditions. Clicking anywhere on the screen restores it.

## The Design/Run Experiment Window

The Design/Run Experiment window provides tools to select, design, edit, and execute experiment macros. (Experiment macros are "scripts" of commands that guide the DeltaVision system to collect images.)

#### To open the Design/Run Experiment window:

- From the Resolve3D window, click the **Experiment** icon, and then click the **Design** tab.

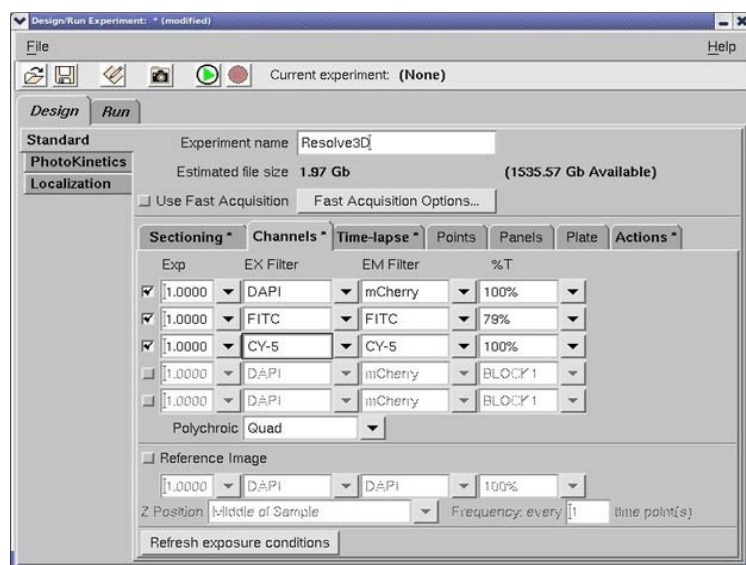

The Design/Run Experiment Window



**Note** The **PhotoKinetics** and **Localization** tabs are available only for systems equipped with a laser module.

### Experiment name

Specifies the name of the experiment macro.

### Use Fast Acquisition

Enables fast acquisition experiments.

### Sectioning Tab

Specifies sectioning for 3D images.

### Channels Tab

Specifies channels and exposure time.

### Time-lapse Tab

Specifies criteria for time-lapse experiments.

### Points Tab

Specifies a list of marked points (see Page E.22) and options for UltimateFocus and Autofocus.

### Panels Tab

Allows you to set up panel collection that you can use to acquire a large area of a slide to stitch together to form a single image.

## Plate Tab

Provides tools for setting up and running microtiter plate scanning experiments when your DeltaVision system is equipped with the Microtiter Stage option.

## Actions Tab

Lets you designate new Laser, Autofocus, and UltimateFocus events, add Pause and Wait times, alter Time-lapse intervals and image status methods, and other specific actions to occur during the experiment.

# Experiment Name and Use Fast Acquisition

## Experiment name

Specifies the name of the file that is generated by the Experiment Designer. A file extension of `.exp` will be added to the name.

## Use Fast Acquisition

Enables fast image acquisition of 2D images.

This data acquisition mode should be used carefully. Fast Acquisition uses a single command to set up a data stream to the Instrument Controller.

There is an upper memory limit for data collection that is based on the size of RAM memory for the Instrument Controller (typically about 1000 MB). If you run into this limitation, turning Fast Acquisition off allows you to collect larger data sets.

If the system is unstable after collecting a large data set with Fast Acquisition, restart the workstation or stop using Fast Acquisition unless it is strictly necessary.

Sometimes Fast Acquisition isn't much faster than standard acquisition, and more is risked than gained by using it.



**Note** You can set Fast Image Acquisition options to control the scan sequence, the shutter open mode, the camera readout mode, and the starting Z location for the scan. (See the online Help for more information.)

---

## Sectioning Setup

Once your microscope is focused near the middle of the vertical zone of interest of your sample, you can use the parameters in the Design Experiment Sectioning tab to control the Optical Sectioning procedure.



**Note** The standard scan direction moves the objective lens towards the specimen.

---

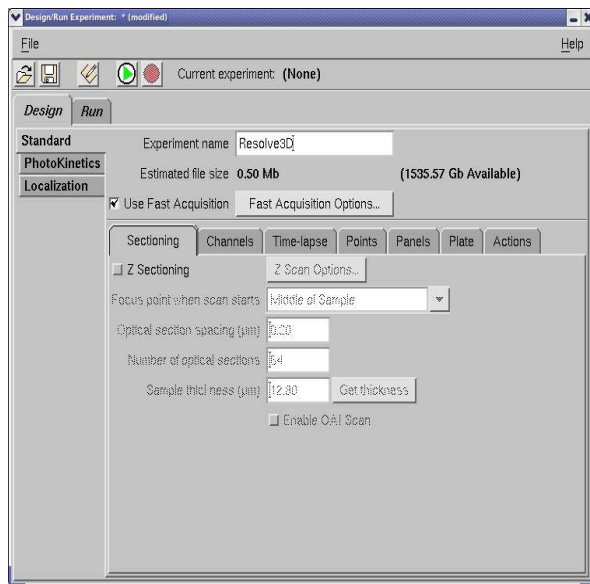

Design Experiment Sectioning Setup Options

### Focus point when scan starts

Specifies the Z location of the sample when the experiment starts. The recommended selection is **Middle of Sample**.

### Optical section spacing

Specifies the spacing (in microns) between each optical section. The focal point will be changed by this value after each image is collected.



### Number of optical sections

Specifies the number of sections to collect (for each wavelength) for the experiment. *softWoRx* automatically calculates and displays this value if the **Sample thickness** and **Optical section spacing** are entered. If you specify this value, the **Sample thickness** value is changed.

### Sample thickness

Displays the **Number of optical sections** multiplied by the **Optical section spacing**.

### Get Thickness

Retrieves the Sample thickness, based on the locations defined with the  and  buttons in the Resolve3D window.

### OAI

Acquires a 2D Z projection of the interval defined by the marked top and bottom of the sample. The optical section spacing and the number of optical sections are determined automatically, based on the depth-of-field of the objective and the exposure time.

## Channels Setup

Use the Design Experiment Channels tab to select wavelengths (filters) and to specify an exposure time for each filter.

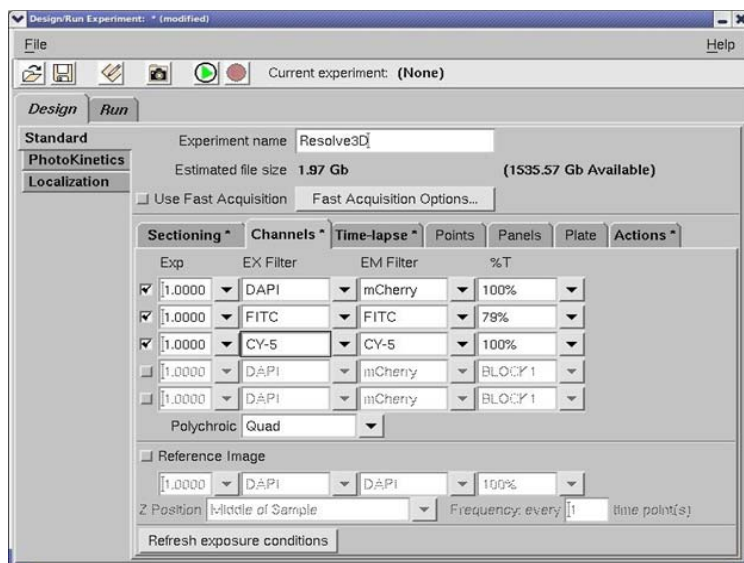

**Design Experiment Channels Options**

### Active Wavelength Check Boxes

Enable the exposure time, filters, and display settings for specific wavelengths. Select the check boxes to activate the wavelengths that you want to collect. (You must select one check box for each wavelength.) If no wavelengths are selected, the exposure and filters that are set in the Resolve3D window are used.

#### Exp

Specifies the exposure time (in seconds) to be used when acquiring an image for the selected wavelength. If left blank, the value specified in Resolve3D will be used when the experiment is run.

#### EX Filter

Specifies the excitation filter to use for this experiment or image. When it is changed, the currently "paired" emission filter is automatically selected.

#### EM Filter

Specifies the emission filter to use. This filter may be selected independently of the EX Filter setting.

#### %T Filter

Specifies the Neutral Density value to use. The % value indicates light transmission. A value of 100 % indicates that no light is blocked.

## Polychroic

Specifies the polychroic filter to use for the experiment. If you have the optional motorized mirror turret installed, it will automatically move the selected polychroic into the light path. The polychroic is moved when the experiment is run.



**Note** This field is available only if the polychroic turret is motorized.

## Reference Image

Specifies to use an alternate filter or the transmitted light to acquire a reference image that can be combined with other images. This option is useful for Differential Interference Contrast (DIC) analysis. It can also be useful for other types of reference images. Only one reference image per Z stack is collected.

## Refresh exposure conditions

Updates the filter and exposure settings to those last used in the main Resolve3D window.

## Time-lapse Setup

Use the Design Experiment Time-lapse tab to specify the number of time points, the time periods, and the total time for a time-lapse experiment.

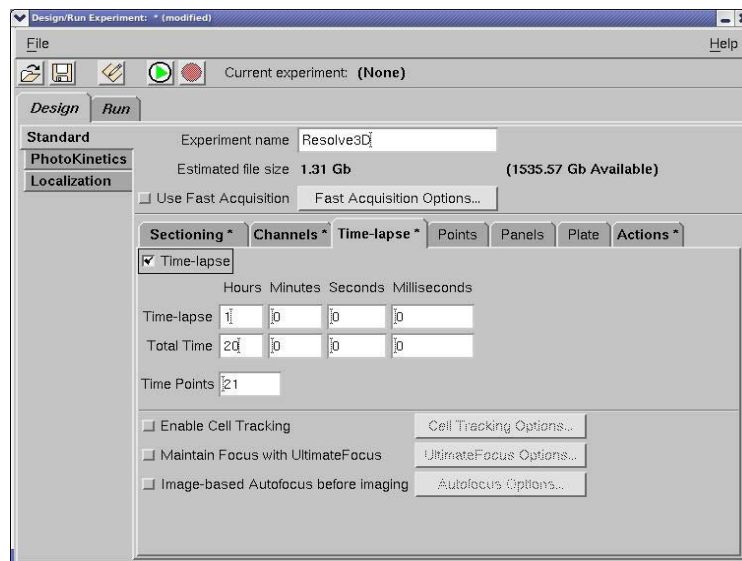

Design Experiment | Time-lapse Setup Options

## Time-lapse option

Specifies running a time-lapse experiment.

## Time-lapse

Specifies the hours, minutes, and seconds between each time period.

## Total Time

Displays the total time of the experiment, which can also be calculated as follows:

$\text{Total time} = (\text{The number of time points} - 1) \times \text{time-lapse}$

Specifying a total time will update the **Time Points** field.

## Time Points

Specifies the number of time samples to collect in a time-lapse experiment. Changing this value will update the **Total Time** field.

## Enable Cell Tracking

Moves the stage laterally to follow cells as they move during a time-lapse experiment. With the **Enable Cell Tracking** option selected, DeltaVision automatically keeps cells in the field of view.

## Cell Tracking Options

Opens the Cell Tracking Options window that allows you to set the parameters for cell tracking. For more information on using the tools on this window, see “Tracking Cells” on Page 5.3.

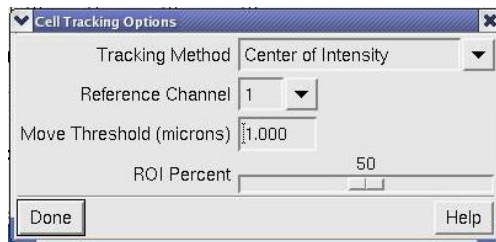

## Maintain Focus with UltimateFocus

Specifies focus should be maintained during the time-lapse experiment. If this experiment does not involve point visiting, a calibration (characterizing the UltimateFocus response at the current location) is performed when the experiment is started.



**Notes #1** The initial focus is essential to the success of focus maintenance.

**#2** The actual focus maintenance process happens just before each time-lapse event.

## UltimateFocus Options

Opens the UltimateFocus Options window, in which you can indicate a specific **Move Threshold** and the **Maximum** (number of) **Iterations** to move within the threshold before re-running UltimateFocus.

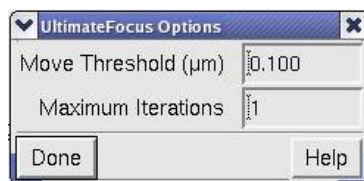

On the UltimateFocus Options window:

- In the **Move Threshold** field, enter the desired maximum measured focus error (in  $\mu\text{m}$ ) before a corrective action should be taken.
- In the **Maximum Iterations** field, enter the maximum measure/move sequences for this action to reach the calibrated focus point.



**Note** More iterations will take longer, but may provide better focus.

---

- Click the **Done** button.

### Image-based Autofocus before imaging

Using the software-based Autofocus function, automatically focus the camera before each time point. For point visiting experiments, the camera is automatically focused every time that a point is visited.

### Autofocus Options

Opens the Resolve3D Settings window to the **Autofocus** tab, in which you can manipulate the settings for the software-based Autofocus function.

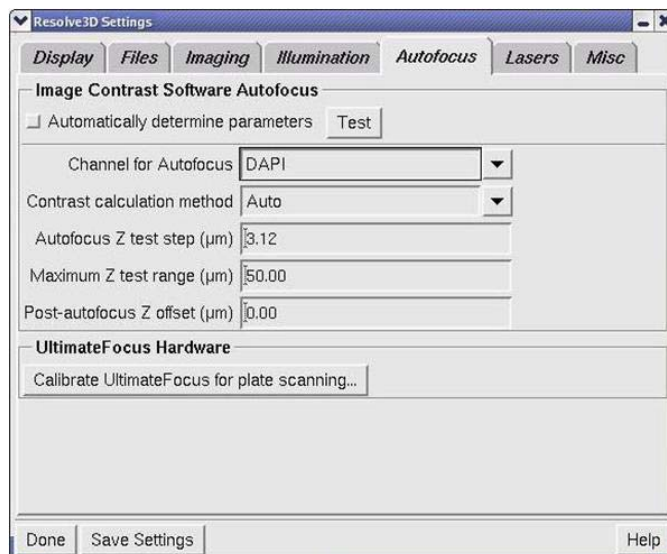

Resolve3D Settings Window | Autofocus Tab

### Point Visiting Setup

Use the **Design Experiment Points** tab to specify a list of marked points to visit during the experiment.



**Tip** Before you specify these points, make sure that there are active points in the point list.

---



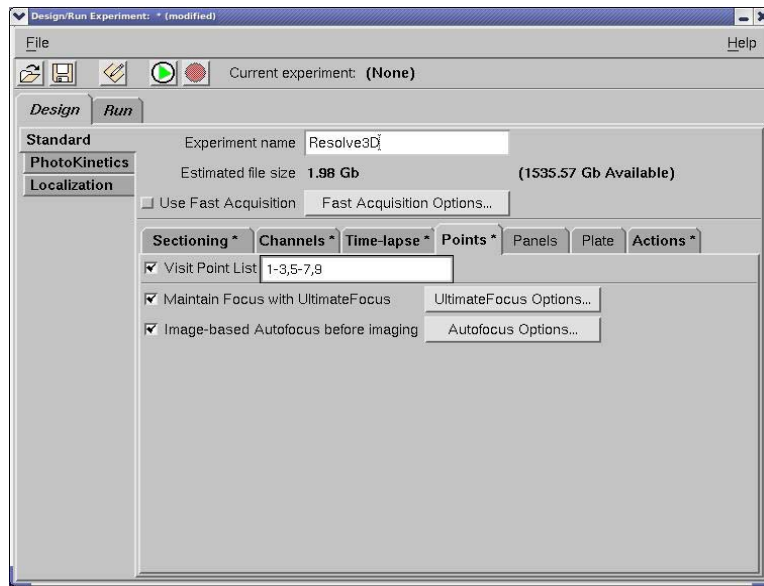

Design Experiment | Point Visiting Setup Options

### Visit Point List

Specifies the list of points (described by number) to visit during the experiment. All sectioning and wavelength procedures are repeated at each of the listed points. A point list can be entered as a series of numbers separated by commas or dashes. Separating two numbers with a dash '-' (as shown in the following example) indicates that all point numbers in between should also be visited.

For example:

1, 2, 5, 7-10



**Note** When you use Point Visiting with Z sectioning, the microscope uses the Z value of the current focus of each point as the initial reference for that point. Values specified for Z sectioning are incremental relative to that point.

### Maintain Focus with UltimateFocus

Specifies focus should be maintained during the point visiting experiment. A UltimateFocus calibration (characterizing the UltimateFocus response at the current location) is performed when the point is initially marked.

## UltimateFocus Options

Opens the UltimateFocus Options window, in which you can indicate a specific **Move Threshold** and the **Maximum** (number of) **Iterations** to move within the threshold before re-running UltimateFocus.

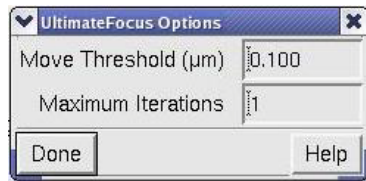

On the UltimateFocus Action Options window:

- In the **Move Threshold** field, enter the desired maximum measured focus error (in  $\mu\text{m}$ ) before a corrective action should be taken.
- In the **Maximum Iterations** field, enter the maximum measure/move sequences for this action to reach the calibrated focus point.



**Note** More iterations will take longer, but may provide better focus.

---

- Click the **Done** button.

## Image-based Autofocus before imaging

Using the software-based Autofocus function, automatically focus the camera before each time point. For point visiting experiments, the camera is automatically focused every time that a point is visited.

## Autofocus Options

Opens the Resolve3D Settings window to the **Autofocus** tab, in which you can manipulate the settings for the software-based Autofocus function.

## Panel Collection Setup

Use the **Design Experiment Panels** tab to create panel collection macros. These macros are useful when you want to scan a large area with a relatively high magnification lens. You can use the panels as a means of reviewing a large area of a slide, or as data that you want to stitch together to form a single, large image.



**Note** Panel collection macros are sensitive to microscope settings such as image size and magnification. Because the number of panels required depends upon many factors, it is usually not a good idea to reuse panel collection macros.

---

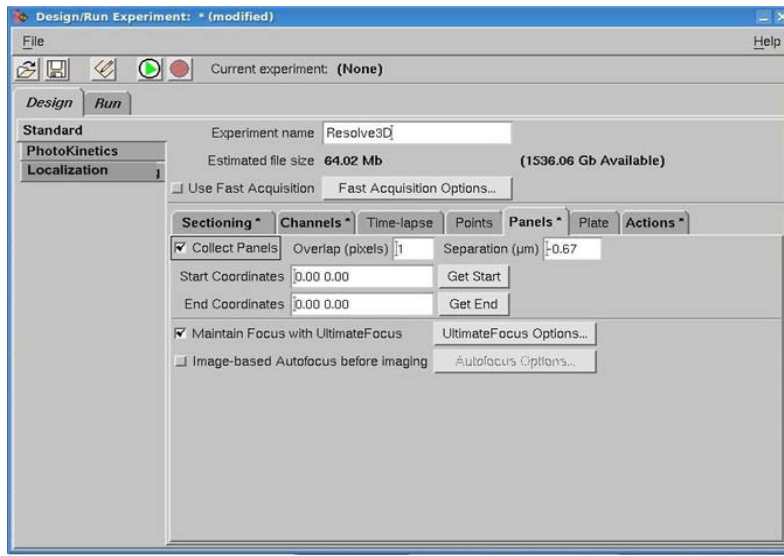

### Design Experiment | Panel Collection Setup Options

#### Collect Panels

Specifies to use a panel collection macro.

#### Overlap (pixels)

Specifies the amount of overlap (in pixels) between adjacent panels.

#### Start Coordinates

Specifies the XYZ coordinates at which to start collecting panels. Use the **Get Start** button to obtain the current XYZ stage coordinates.

#### End Coordinates

Specifies the XYZ coordinates at which to finish collecting panels. Use the **Get End** button to obtain the current XYZ stage coordinates.



**Note** These coordinates will be included at minimum. Based on CCD size, the final collection area may be larger than specified.

## PhotoKinetics Tab

The TIRF/PK Module provides the ability to add a laser beam into the optical path of the DeltaVision microscope. A laser beam is introduced into the back aperture of the microscope objective to provide a focused illumination spot in the center of the optical field. With lasers attached (like the DeltaVision X4 Laser Module), users can design photokinetic experiments. The TIRF/PK Module is optional for the DeltaVision system and is offered in three varieties: TIRF/PK, TIRF only, and PK only.

The **PhotoKinetics** tab provides options for designing the nature of a photokinetic event, setting up the event timing, setting image conditions to associate with the event, and defining the locations of photokinetic events.

## Running Photokinetic (PK) Experiments

The Resolve3D Design/Run Experiment window contains basic photokinetic experiments such as FRAP (fluorescence recovery after photobleaching).

### To run a basic PK experiment:

1. Click the **Experiment** button in the Resolve3D main menu to open the Design/Run Experiment window.
2. Select the **Design** tab, then select the **PhotoKinetics** tab.
3. On the **Laser Events** tab, select the desired laser from the drop-down menu.

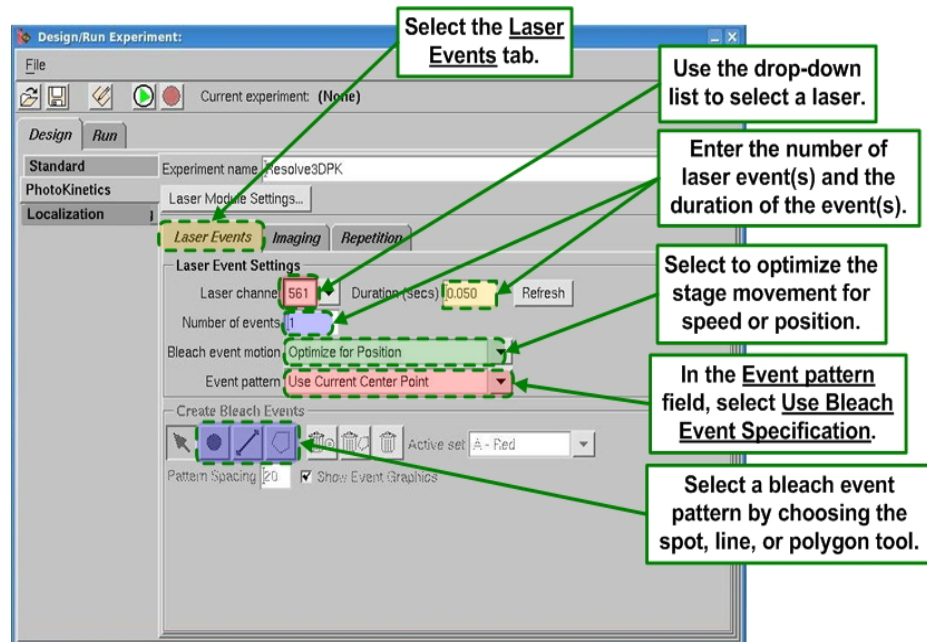

4. To generate multiple bleach events, the stage moves the sample to the site of laser activity. You can optimize this motion for either speed or position. When **Optimize for Position** is selected, the stage goes through an LMC (Lost Motion Compensation) move to achieve the most accurate position. This move takes more time than when **Optimize for Speed** is selected.
5. Bleach events occur at either the center point of the field of view or in a specified position. Select **Use Bleach Event Specification** in the **Event pattern** field.
6. In the Create Bleach Events section of the window, select an event pattern by choosing the spot, line, or polygon tool.
7. Click on the image in the Data Collection window to generate the selected bleach pattern.

8. Click on the **Imaging** tab to select the **Channel Setup** (exposure time, wavelength, and illumination source settings) and **Time Course Specification** conditions.

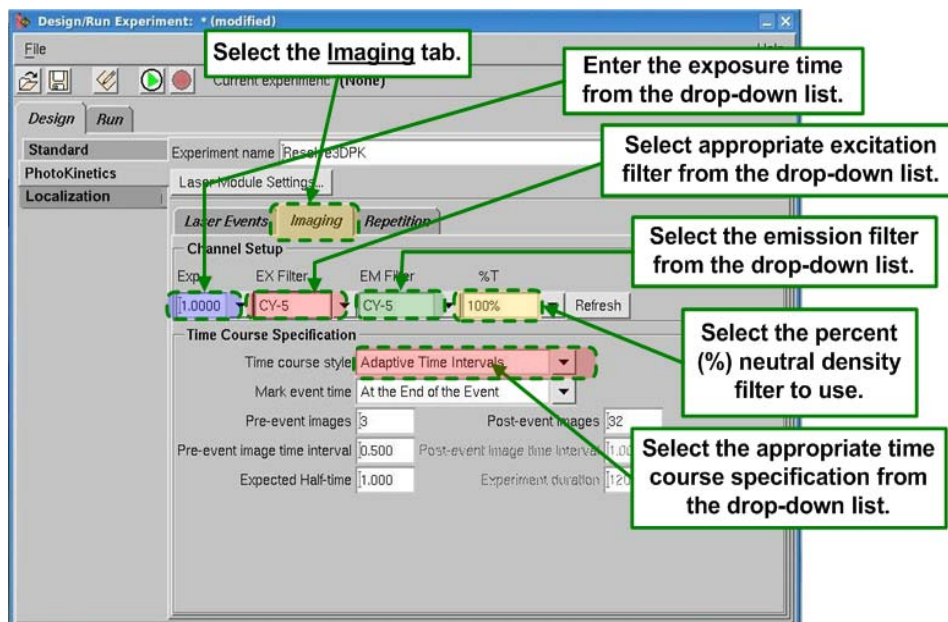

9. When you select the Time course style, the drop-down list presents three choices:
- **Adaptive Time Intervals** – allows you to select the total number of images to be collected. Images are collected faster after the bleach event and then slower over time.
  - **Uniform Time Intervals** – allows you to select the total number of images collected, as well as the time interval between images. The value in the **Experiment Duration** field is calculated based on these factors. Also, if you change the value in the **Experiment Duration** field, the **Post-event images** field automatically updates.
  - **As Fast As Possible** – collects the images in rapid succession with no time-lapse interval. For this style, you enter only the total number of **Post-event images**.



**Note** The **Localization** tab shown in the above image is a licensed-only option..

## The Run Tab

Use the **Run** tab options to access tools that allow you to select and execute experiment macros. There are also controls to monitor and interact with a running experiment.

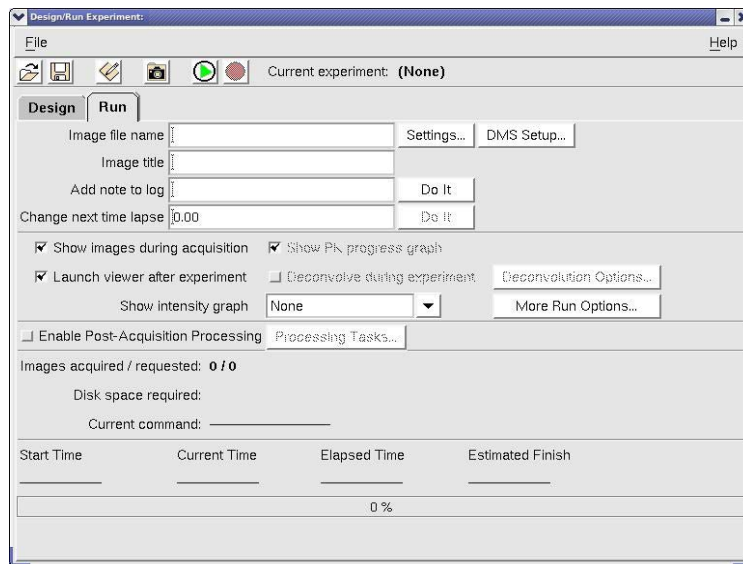

### The Run Experiment Tab



**Note** The **Design PK Experiment** tab is available only for systems equipped with a laser module.

### The Green Arrow Button

Starts the selected macro to run an experiment.

### Image file name

Specifies the file name to use for the image in this text field. If you do not provide a file name, you will be asked to provide one when the experiment starts running. If you have the **Auto-increment file names** setting (in the Settings window) turned on, you will only need to provide a name once for each session. The names will have incrementing numbers appended to them automatically.

### Image title

Specifies text to save in the header of the image file created by the experiment. The title can be viewed later using the **Header Labels** button of the Image window's Image Information window.

### Add note to log

Inserts a note in the experiment's log file at any time before or while an experiment is running. (You will need to click **Do It** to insert the note.)

### Change next time lapse

Changes the time lapse value while an experiment is executing. (You will need to type the desired time, in seconds, in the text field and click the **Do It** button to change the

value.) This value only affects experiment macros that contain a TLAPSE command. It does not permanently change the macro.



**Note** This option is available only for time-lapse images.

## Schedule Post-Acquisition Processing Tasks

Displays the Post Processing Options window.

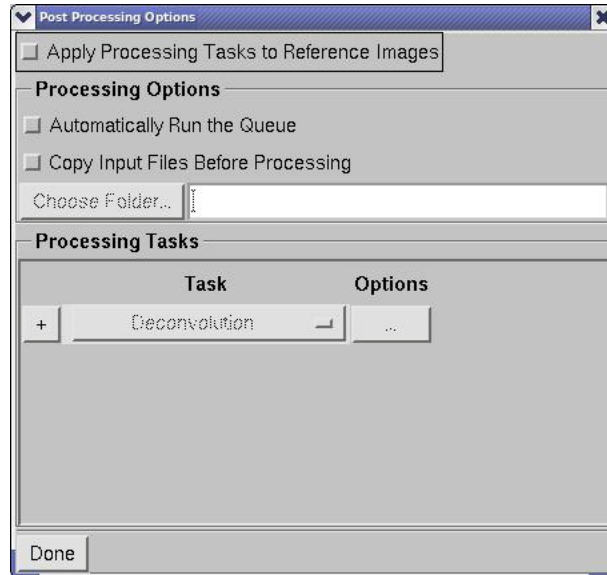

Refer to the section “*Scheduling Post-Acquisition Processing Tasks*,” in the [softWoRx Imaging Workstation User’s Manual](#) for complete information on the options available from this window.

## Images acquired/requested:

Displays the current number of images acquired, compared to the total number requested. (During fast acquisition, the reported number of acquired images may not be updated regularly.)



**Note** The request portion of this is updated as the experiment is designed.

## Disk space required

Displays the estimated size of the experiment (i.e., the size of the image file). Resolve3D checks the disk space to make sure that enough space is available on the selected volume before it runs the experiment.



**Note** The disk space required value is updated as the experiment is designed.

## Elapsed time:

Displays the elapsed time of the experiment, in seconds.

### Estimated Finish

Displays the estimated clock time in which a running time-lapse experiment will finish.

### Current command:

Reports each macro command as it is executed.

### The Cancel Scan Button

Terminates a running experiment. (The images that are collected before the experiment is cancelled are automatically saved.)

### Help

Opens the online Help for the Design/Run Experiment window.

## The Settings Window

Use the Resolve3D Settings window to control how images are displayed, select camera settings, and specify file output.

### To open the Settings window:

- From the Resolve3D Window, click the **Settings** icon.

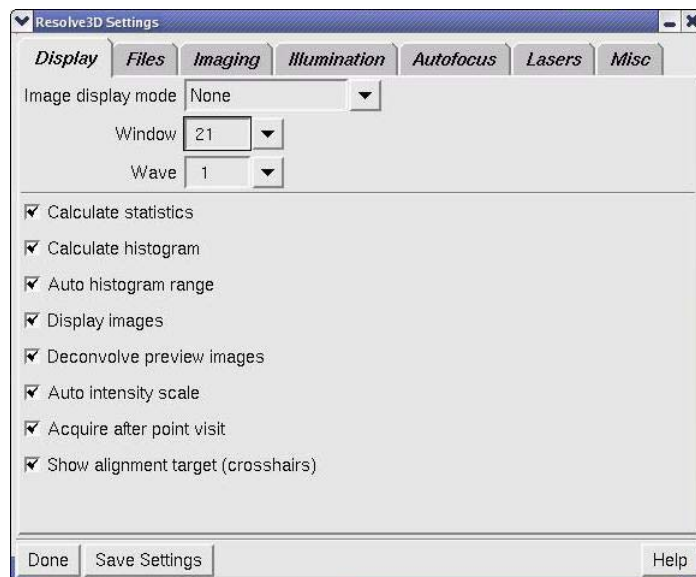

### The Settings Window | Display Options



**Note** The **Lasers** tab is available only for systems that have lasers installed.

## Settings Window Display Options

The Settings window Display tab options allow you to control how the images are displayed and what information about them is available.



## Image Display Mode

Specifies which window and wave are used for image display. Five modes are currently available:

Mode	Description
None	Displays images in the current window.
Scratch	Displays all images in the default Data Collection window (Window 21).
Auto Grayscale	Displays images in a separate window for each emission filter.
Auto Color	Displays images in color as they are collected. When using Point Visiting, images are automatically displayed in separate windows for each point. This option should be used only when you are running an experiment.
Point Track	Opens a separate window for each visited point in a point-visiting experiment.

## Window

Specifies the number of the data collection window, sometimes referred to as the "Scratch" window. Select a new window to change where the next image will be displayed. (Temporary windows are numbered 21 or higher.)

## Wave

Specifies the number of the wave (channel) that will receive the next image in the Data Collection window. Select a new wave to change which display window channel to use.

## Calculate statistics

Calculates image intensity statistics. The typical reason for disabling this feature is to improve readout speed.

## Calculate histogram

Calculates and displays the image intensity histogram in the Resolve3D status area during image collection. (This option does not set scaling.)

## Auto histogram range

When enabled, automatically scales the Resolve3D status area histogram width for each image that is acquired, so that the histogram display ranges from the minimum to the maximum intensity. When disabled, the status area histogram is scaled to the full range of a typical CCD.

## Display images

Displays images when the **Acquire** button is clicked or an experiment is running. Deselecting this option can increase performance.

## Deconvolve preview images

Displays instantly processed 2D image previews that closely resemble images processed with advanced 3D image restoration techniques.

### Auto intensity scale

Provides automatic scaling of the image intensity between the minimum and maximum brightness. (This switch applies only to the appearance of the displayed image, not the actual data.)

### Acquire after point visit

Automatically acquires an image when the Visit Point option is selected.

### Show alignment target (crosshairs)

Displays crosshairs over the data collection window indicating the location of the image center.

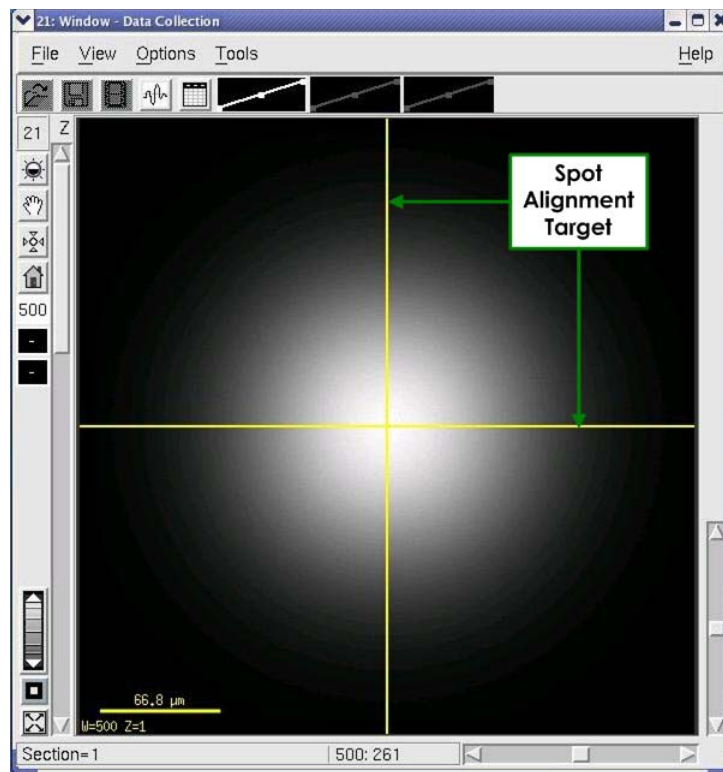

Show Alignment Target

## Settings Window Files Options

Use the Settings window File options to set the image output directory, set the directory where experiment macros are stored, and select auto incrementing for file names.

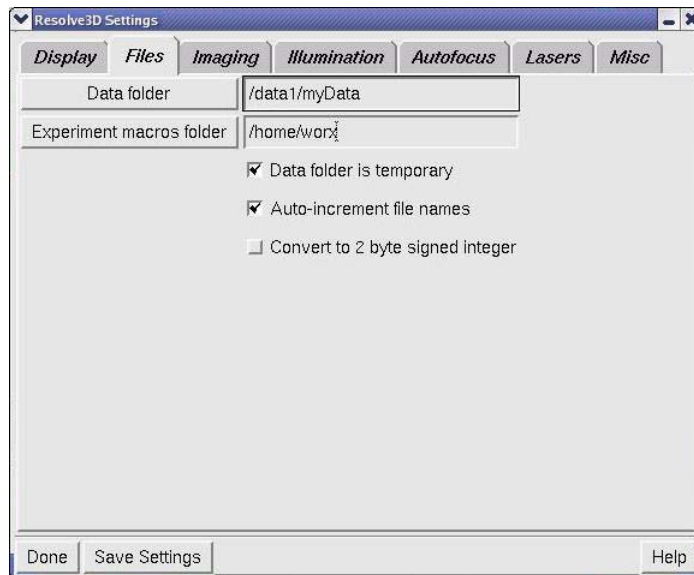

The Settings Window | Files Options

### Data Folder

Specifies the destination directory for Resolve3D output images. If you supply a directory that you do not have permissions to use, you will be warned. If you provide a directory name that does not exist, you will be presented with the option of creating the directory. (You can also change the destination directory by changing the global *softWoRx* Image Data Directory in the User Parameters tool.)

### Experiment macros folder

Specifies the directory where your experiment macros are stored.

### Data folder is temporary

Specifies that any directory entered in the **Data Folder** field only applies to the current Resolve3D session. In subsequent Resolve3D sessions, the Data folder value reverts back to the global *softWoRx* Data Directory as specified in User Parameters.

Use this option in environments where several users are running the microscope and using a single system login. Data folders can be created for each user under a common parent folder. As users start Resolve3D, they can choose to use their own folders.

In most cases, you should not use this option if each user has their own system login in your environment. With the option deselected, the Data folder assignment modifies the global *softWoRx* Data Directory definition and the system remembers the directory used in the last Resolve3D session.

### Auto-increment file names

Creates a new file name by appending a serialized number to the base file name each time you run an experiment.

### Convert to 2 byte signed integer

If enabled, Resolve3D saves all images as signed 16-bit (the softWoRx default). This setting is designed to increase compatibility with older software. Note that this setting cannot be enabled for EMCCD cameras.

## Settings Window Imaging Options

The Settings window Imaging options allow you to select camera settings.

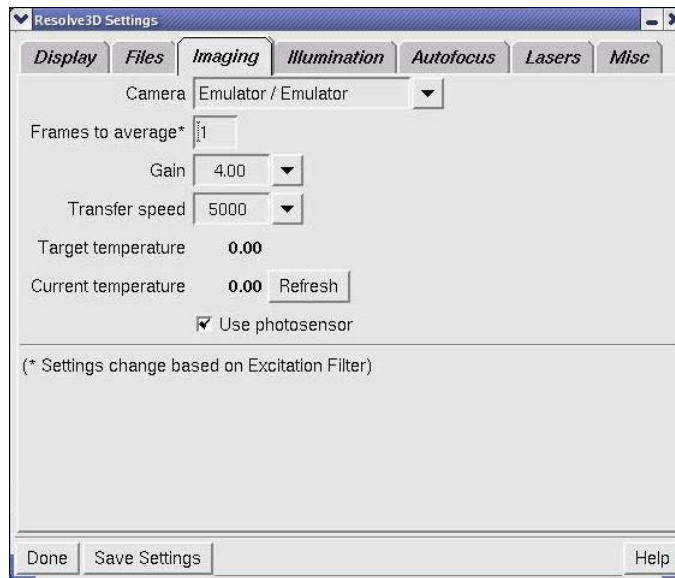

The Settings Window | Imaging Options

### Camera

Specifies which camera to use. For the EMCCD camera, this list also specifies whether to use Conventional or Electron Multiplication mode.

### Frames to average

Specifies the number of successive camera images to average into a result that is displayed in the window, increasing signal to noise. (This is similar to the AVG macro command.)

### Gain

This field allows you to specify a gain value for the selected camera.

### Transfer speed

Specifies a transfer rate for the selected camera (in kHz). Higher speeds may boost performance at the expense of image noise.

## Target temperature

This field displays the cooled CCD camera's target temperature. This can be changed only by modifying the appropriate configuration file on the Instrument Controller computer.



**Note** Not all cameras can be temperature controlled.

---

## Current temperature

This field displays the current temperature. Resolve3D monitors the temperature and updates this value occasionally. If you want to force a request for the current temperature, click the **Refresh** button.

## Use photosensor

Enables use of the photosensor.

## Settings Window Illumination Options

Use the options on the Resolve3D Illumination tab to set up illumination parameters.

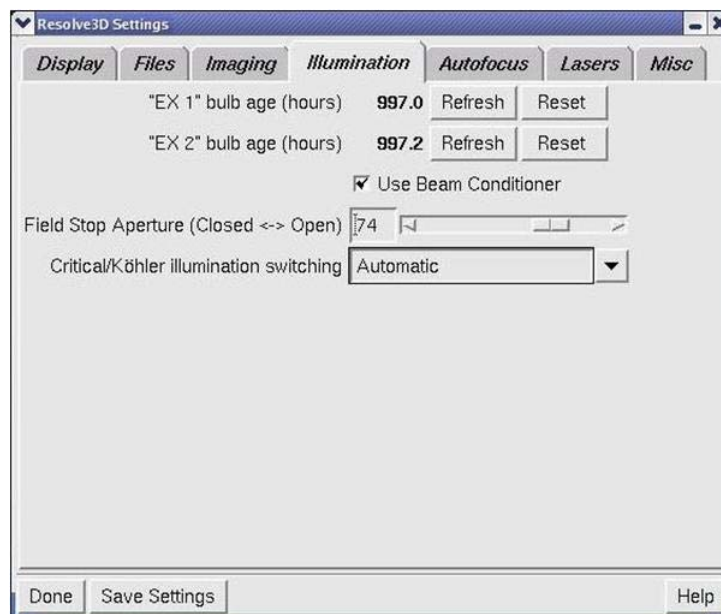

## "EX 1" and EX 2" bulb age (hours)

These fields provide figures for the current number of hours of use on each xenon bulb.



**Note** The **EX 1** and **EX 2 bulb age (hours)** settings are displayed only if your DeltaVision system is using an internal xenon lamp(s) for broadband illumination.

---

### Use Beam Conditioner

Use the beam conditioner to improve cell viability. When the **Use Beam Conditioner** check box is enabled, a filter is placed into the excitation path that blocks near-UV wavelengths which are typically lethal to living cells.



**Note** DAPI, CFP and similar blue wavelength excitation will be blocked when using the beam conditioner.

---

### Field Stop Aperture (Closed <-> Open)

This field allows you to set the field stop aperture to **Closed**, **Open**, or any percentage in between. You can either enter a percentage in the field or use the slider to set the percentage.



**Note** When the setting is set to **Closed**, the field stop aperture is about 20µm in diameter.

---

### Critical/Köhler Illumination Switching

On an Automated Fluorescence Illumination Module, there are three choices for the motorized Critical/Köhler illumination position:

- **Automatic** – DeltaVision automatically adjusts the position of the critical/Köhler illumination when the EX shutter is opened using the keypad (typically when the eyepieces are being used). The position is automatically returned to critical illumination when an image is requested, either via Resolve3D or by running an experiment. Note that this is not the case when using image sizes above 1024 X 1024. To avoid vignetting, the position is not automatically returned to the Critical position for these larger image sizes.
- **Always Critical** – DeltaVision moves the critical/Köhler motor to critical illumination and leaves it in its position regardless of the current shutter states.
- **Always Köhler** – DeltaVision moves the critical/Köhler motor to Köhler illumination and leaves it in its position regardless of any new image requests or experiments running.

## Settings Window Autofocus Options

Use the options on the Resolve3D Autofocus tab to set up Autofocus parameters.

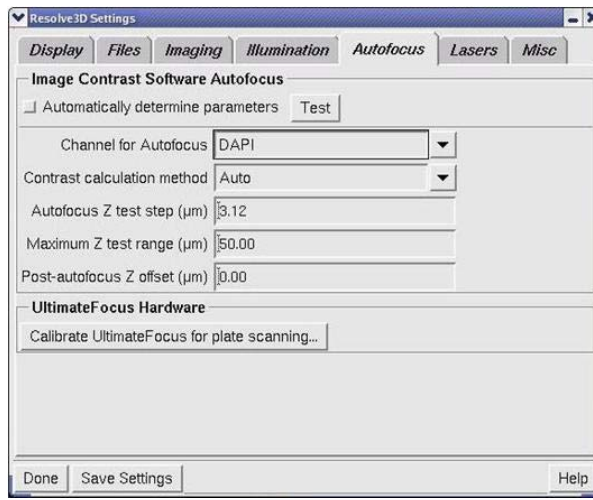

Settings Window | Autofocus Options

### Automatically determine parameters

Autofocus parameters are determined from the depth of field of the objective lens, which is calculated from the lens' numerical aperture. You must select the proper objective lens in order to get the appropriate Autofocus settings. When the **Automatically determine parameters** check box is activated, the remaining fields in this window are set automatically.

### Channel for Autofocus

This setting indicates the wavelength to use for Autofocus.

### Contrast calculation method

This setting determines the polarity of the contrast calculation. There are three choices for image contrast calculation methods:

- **Auto** – The instrument controller usually can determine which contrast calculation method to use, but not always.
- **Fluorescence** – for light objects on a dark background
- **Brightfield** – for dark objects on a light background

### Autofocus Z test step (µm)

This option sets the step size used for Autofocus within the maximum Z range.

### Maximum Z test range (µm)

This setting indicates the maximum range that the Autofocus will search.

## Post-autofocus Z offset ( $\mu\text{m}$ )

This setting can provide a constant offset after the Autofocus position determines the best plane of focus. Often times Autofocus will find a plane that is consistently different from the desired plane.

## Calibrate UltimateFocus for Plate Scanning

This button displays the UltimateFocus Plate Calibration window.

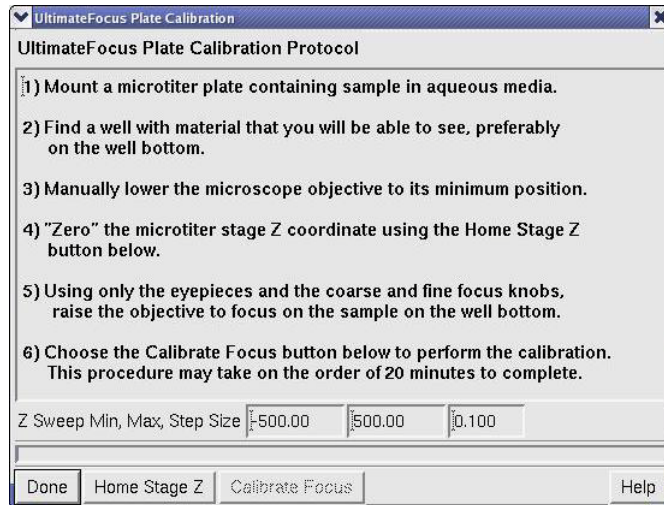

This window provides a procedure for plate calibration. The **Home Stage Z** and the **Calibrate Focus** buttons at the bottom of the window are used in the calibration procedure. You can also set the **Z Sweep Minimum**, the **Z Sweep Maximum**, and the **Z Step Size** from this window.

When working with microtiter plates, many factors affect the performance of UltimateFocus, such as stage angle, plate flatness, plate angle and more. These types of issues are mitigated by characterizing UltimateFocus response over a larger Z range in a single well. This characterization (or calibration) is then used during the course of an entire plate scan. The boxes at the bottom of the calibration tool are used to limit the calibration Z range (**Z Sweep Min/Max**) and the **Step Size** which is used between UltimateFocus calibration measurements. Typically, the entire Z range is used with a step size of  $0.20\ \mu\text{m}$ . Using step sizes smaller than this can cause calibration to take longer to finish and may not increase performance.

## Settings Window Lasers Options

Use the options on the Resolve3D **Lasers** tab to set up parameters for the attached lasers.



**Note** If no lasers are installed on your DeltaVision imaging system, the **Lasers** tab is not displayed.



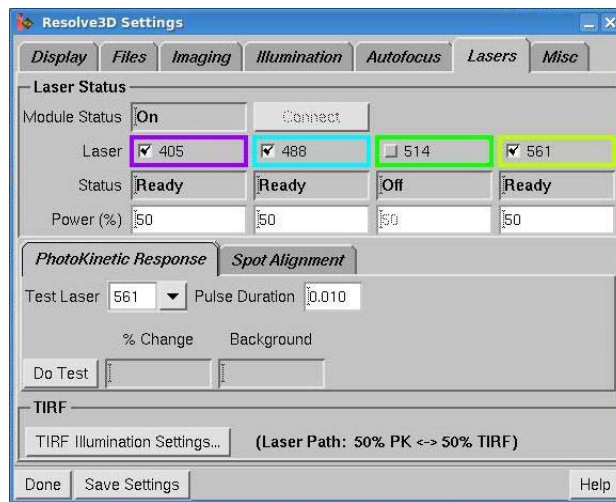

**Settings Window | Lasers Options**

## The PhotoKinetic Response Tab

Activate the **PhotoKinetic Response** tab for the following options.

### Laser

This field displays the peak wavelength for each laser currently installed on the DeltaVision system. Activate or deactivate the individual check boxes to turn laser emission on or off.

### Status

Each field shows the current status of the associated laser. The fields will display **Off**, **Stabilizing**, or **Ready** for each installed laser.

### Power (%)

Each field displays the percentage of power currently applied to each laser.

### Test Laser

Use the drop-down list in this field to select a specific laser on which to run PK tests.

### Pulse Duration

Enter the laser pulse duration for imaging the spot.

### Do Test

Perform a bleach test using the current Power and PK Duration settings.

### % Change

The value entered in this field displays a before and after comparison of the intensities at the bleach spot:  $100 \times (\text{Signal After} / \text{Signal Before})$ .

### Background

The value in this field provides a measurement of the signal (intensity value) after the bleach event.

### The Spot Alignment Tab

Activate the **Spot Alignment** tab for the following options.

### Test Laser

Use the drop-down list in this field to select a specific laser on which to run PK tests.

### Emission

Use the drop-down menu to select the EM filter for imaging the spot.

### Pulse Duration

Enter the laser pulse duration for imaging the spot.

### Image The Spot

Selecting this button opens the laser shutter and acquires a single image of the laser spot. The event duration is set using the **Exposure** field in Resolve3D.

### Continuous

Selecting this button opens the laser shutter and acquires continuous images of the laser spot. Select **Stop Imaging** to discontinue the imaging process.

### Show spot alignment target

Activate this check box to include a target alignment reticle on the displayed test image as shown below.

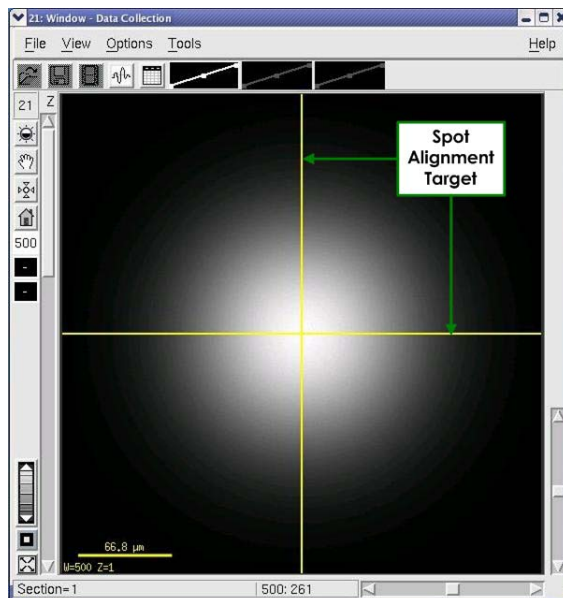

PK Laser Tests | [Image The Spot](#)

## TIRF Illumination Settings

Selecting this button opens the TIRF Illumination Settings window.

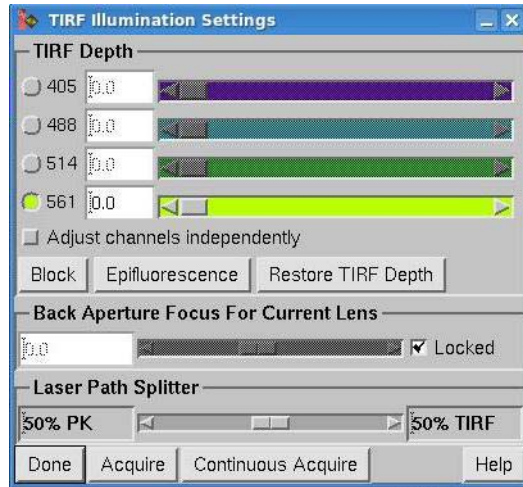

**TIRF Illumination Settings Window**

From the TIRF Illumination Settings window, the following actions are available:

- **TIRF Depth** – allows you to select a laser to adjust its evanescent wave depth.
- **Adjust channels independently** – selects whether to independently adjust the TIRF Depth sliders. With the check box activated, you can adjust the depth setting for each laser separately.



**Note** Keep in mind that adjusting these separately means a significant time penalty for imaging.

- **Block** – sets the TIRF depth adjuster to a position that prohibits illumination of the sample.
- **Epifluorescence** – sets the TIRF depth adjuster for epifluorescence (the highest value of the TIRF depth slider).
- **Restore TIRF Depth** – restores the TIRF depth adjuster to the last-used TIRF position.
- **Back Aperture Focus for Current Lens** – focuses the laser on the back aperture of the objective resulting in a collimated illumination laser and an even TIRF depth across the field of view. This value should be set once for each installed objective. To make sure this position is set correctly for imaging, verify the proper objective is selected from the Resolve3D drop-down menu. The **Locked** check box (activated by default) keeps the slider from being inadvertently moved.
- **Laser Path Splitter** – sets the percent of laser light to be directed to the TIRF illumination path versus the PK path.

## Settings Window Misc Options

Use the options on the Resolve3D Settings window **Misc** tab to select or clear Lost Motion Compensation or to select a filter wheel configuration (if your system is configured to use alternate filter wheels).

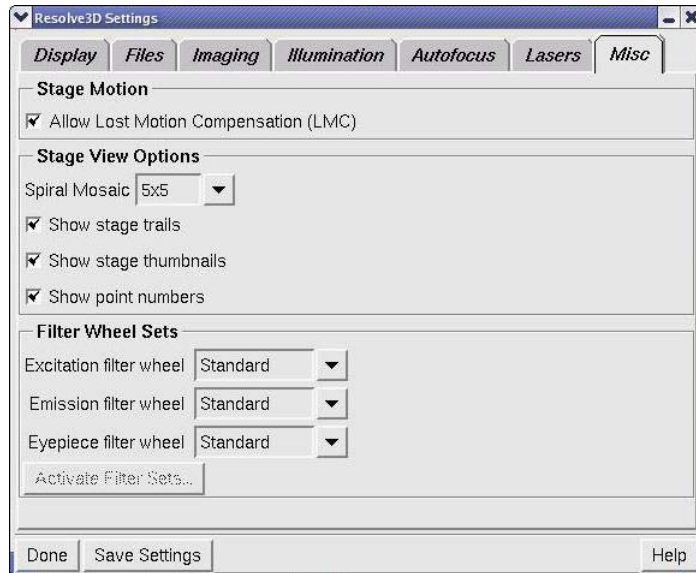

The Settings Window | Misc Options

### Allow Lost Motion Compensation (LMC)

Enable Lost Motion Compensation to remove the effect of hysteresis in the stage. This option should be selected for most applications. When the option is turned off, the Z focal plane may shift depending on the direction of approach. Clear this option if you want to improve speed at the expense of position repeatability.

### Spiral Mosaic

Sets the size for the Spiral Mosaic preview collection pattern centered at the current stage location. The pattern begins at the center and then continues acquiring thumbnail images directly adjacent to it, spiraling outward in a counter-clockwise rotation so that the entire area centered around the initial stage position is previewed in the Resolve3D Stage View. Thumbnail collection continues until either the preset spiral mosaic size (set here) is reached or you click the **Spiral Mosaic** button again. The stage is always returned to the initial position regardless of how the collection ends.

### Show stage trails

Display the path of stage movement on the Resolve3D Stage View.

### Show stage thumbnails

Display a thumbnail image of each image on the Stage View as the image is acquired.

### Show point numbers

Display the number of each point in a point list on the Stage View.

## Filter Wheel Sets

Use these fields to switch between available filter sets.

## Activate Filter Sets

This button re-initializes the filter wheels after changes have been made in any of the above fields. Finalizes any new selections made to the **Filter Wheel Sets** fields and may include re-initializing filter wheels.

## Action Buttons

### Done

The **Done** button closes the Resolve3D Settings window.

### Save Settings

The **Save Settings** button preserves the current options for your next Resolve3D session. In addition to options in the Resolve3D Settings window, current state information such as currently selected filters and exposure time is saved.

### Help

The **Help** button opens the online Help for the Settings window.

## Keypad/Joystick Operation

Many of the functions accessible through Resolve3D are also available on the keypad/joystick. This section describes each key on the keypad/joystick.



**Note** DeltaVision is currently being shipped with one of two keypad/joysticks. The 12-key Keypad/Joystick is described below. For complete usage information for the 46-key Keypad/Joystick, see the following section.

### 12-key Keypad/Joystick

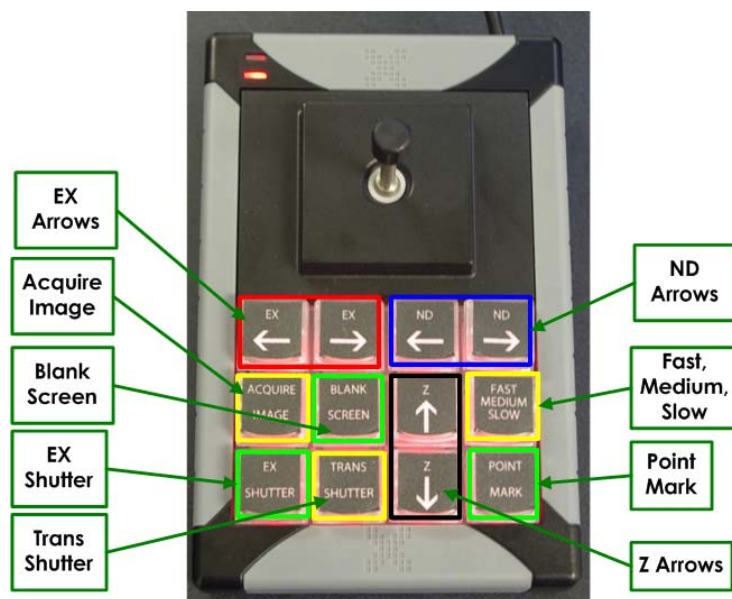

DeltaVision 12-key Keypad/Joystick

#### Acquire Image

With the microscope set to Camera Mode, the ACQUIRE IMAGE button acquires an image and displays it on the monitor. Use this key when you are scanning through your sample and want to get a quick look at the specimen on the monitor. (Note that Resolve3D must be running at the time.)

#### EX Shutter

Opens or closes the Excitation (i.e., Fluorescence) shutter. You will use this control frequently to open and close the shutter. Because the shutter is designed to protect your eyes from exposure to ultraviolet light, it automatically closes each time that the eyepiece filter wheel is moved. It must be reopened with the EX SHUTTER button.

#### Blank Screen

Suspends (or activates) the monitor's light display (BLANK SCREEN is a toggle button). Use this feature when viewing dim samples or performing light sensitive experiments.

### Trans Shutter

Toggles the transmitted light LED between off and on. (Subsequent to changing the transmitted light source from halogen to LED, an actual shutter is no longer necessary.)

### Slow, Medium, and Fast

Control the speed that the stage is moved using the joystick. This key functions as a toggle. Each time the key is pressed, the controller moves to the next mode. The order is FAST, MEDIUM, and SLOW and the display will show "Stage speed: X," where X is the current stage speed. Also, the green LED on the keypad provides the following indicators:

- When the FAST stage speed is selected, the green LED flashes twice.
- When the MEDIUM stage speed is selected, the green LED flashes once.
- When the SLOW stage speed is selected, the green LED does not flash at all.

It's usually best to start with the Medium stage speed.

### EX Arrow Keys

EX LEFT-ARROW moves the selection to the previous EX filter location. EX RIGHT-ARROW moves the selection to the next EX filter location.



**Note** The order of the EX locations should match the configuration file EX table.

---

### ND Arrow Keys

ND LEFT-ARROW moves the selection to the previous ND filter location. ND RIGHT-ARROW moves the selection to the next ND filter location.



**Note** The order of the ND locations should match the configuration file ND table.

---

### Z Arrow Keys

Moves the stage in the Z direction indicated.

### Point Mark

Adds the current stage position to the marked points list.

### The Joystick

Controls stage movement. Use the joystick to move the stage in the direction that you point with the joystick (for example, moving the joystick up moves the stage away from you, moving joystick left moves the stage to the left, and so on).

## 46-key Keypad/Joystick



**Note** DeltaVision is currently being shipped with one of two keypad/joysticks. The 12-key Keypad/Joystick is described in the previous section.

---

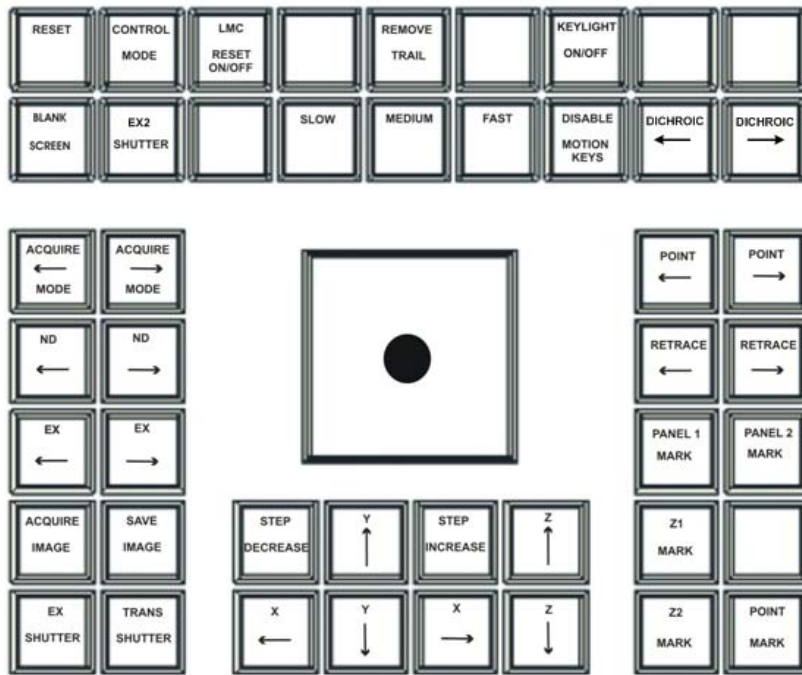

DeltaVision 46-key Keypad/Joystick

## RESET

Clears communication buffers, closes shutters, stops all motors, and clears encoder errors. Use the RESET button when you suspect that the workstation and controller are not synchronized.

## CONTROL MODE

Toggles the controller mode between local mode and remote mode. Local mode enables control by the keypad and joystick. The remote mode disables the joystick and the keypad buttons (except for CONTROL MODE and a few other buttons) and shifts control to other internal components.

## LMC RESET ON/OFF

Executes a Lost Motion Compensation (LMC) move.



**Tip** You can disable LMC on the Resolve3D Settings window. (For more information, see the online Help.)

## REMOVE TRAIL

Clears the stage movement history from memory.

## KEYLIGHT ON/OFF

Turns the keypad backlight on and off.



### BLANK SCREEN

Suspends (or activates) the monitor's light display (BLANK SCREEN is a toggle button). Use this feature when viewing dim samples or performing light sensitive experiments.

### SLOW/MEDIUM/FAST

Adjusts the joystick stage movement speed.

### DISABLE MOTION KEYS

Disables the eight keys below the joystick. This prevents accidental input from the keys when using the joystick.

### ACQUIRE MODE ARROWS

Changes the acquisition mode as set in Resolve3D. (This includes the Excitation filter, exposure time, shutter configuration, and many of the options defined in the Settings window.)

### JOYSTICK

Moves the stage in X and Y.

### POINT ARROWS

Scrolls through the list of marked points. Press ACQUIRE IMAGE to view the image for a selected marked point.

### ND and EX ARROWS

Changes the neutral density (**ND**) or excitation (**EX**) selection up or down the list.

### ACQUIRE IMAGE

Commands the system to collect image data. This key function is identical to clicking **Acquire** in Resolve3D. Use this key when you are scanning through your sample and using the eyepiece to find a region of interest, or when you want to get a quick look at the specimen on the monitor.

### SAVE IMAGE

Saves the last acquired image to the currently open file.

### STEP DECREASE/INCREASE

Changes the step size of the movement controlled by the arrow keys located beneath the joystick. Pressing either button many times will change the step size to the minimum/maximum. There are 8 possible step sizes: 50nm, 100nm, 200nm, 400nm, 800nm, 2250nm, 4500nm, and 9000nm.

### X AND Y ARROW KEYS

Move the stage in the direction shown.

### Z ARROW KEYS

Move the stage in the direction shown.

### Z1 MARK/Z2 MARK

Mark the bottom (**Z1**) and the top (**Z2**) of the focal plane for your sample.

### EX SHUTTER

Toggles the excitation shutter between open and closed.

### TRANS SHUTTER

Toggles the transmitted light source between On and Off.

### POINT MARK

Adds the stage position to the marked points list.

## Appendix F. Lasers and Safety Issues

---

This appendix describes the necessary precautions to take when working with instruments containing lasers, including required safety labeling and label locations. The appendix is divided into two main sections.

- *Olympus FI Laser Safety* provides laser safety information for the DeltaVision X4 Laser Module when used in conjunction with the Olympus Fluorescence Illumination Module.
- *Automated FI Laser Safety* provides laser safety information for the DeltaVision X4 Laser Module when used in conjunction with the Automated Fluorescence Illumination Module.

Much of the information presented is redundant from one section to the next, but not all. Please read the sections carefully to determine the proper safety measures to take for your particular DeltaVision laser configuration.

### Olympus FI Laser Safety

This section describes the hazards and precautions to take when using the DeltaVision X4 Laser Module in conjunction with the Olympus Fluorescence Illumination Module. These hazards and precautions must be fully reviewed and understood, and proper safety protocols followed during any use of the DeltaVision X4 Laser Module.

The DeltaVision X4 Laser Module is a Class 3B laser system.

## Important Safety Recommendations

The X4 Laser Module contains up to three 50mW lasers and one 100mW laser, and is considered a Class 3B device. This means that radiation from all installed lasers can exit the device at the same time. The power level is high enough to cause damage to the human eye instantaneously.

OSHA regulations require (via ANSI Z136.1) and IEC 60825-1 recommends that a Laser Safety Officer be identified who will be responsible for the safe use of Class 3B lasers. This includes training users, installing all necessary warnings and controls in the laser area, and other duties.



**WARNING:**

Given the inherent exposure possible with an inverted frame microscope stand, users of the system *must be trained in laser safety before using this instrument*. Contact your lab administrator for information about Laser Safety training at your institution. Training is also available online at:

[www.kentek-laser.com/edu/lasercrs.htm](http://www.kentek-laser.com/edu/lasercrs.htm)

The International Electrotechnical Commission (IEC) and the FDA recommend that Class 3B and Class 4 lasers be used only in restricted areas.

## Safety Features

The Laser Module provides several features that control access to the device and improve its safety.

- The Key Lock switch on the front panel of the Laser Source Chassis must be in the **LASER ON** position to enable use of the lasers. The key can be removed only when this switch is in the **LASER STAND-BY** position.

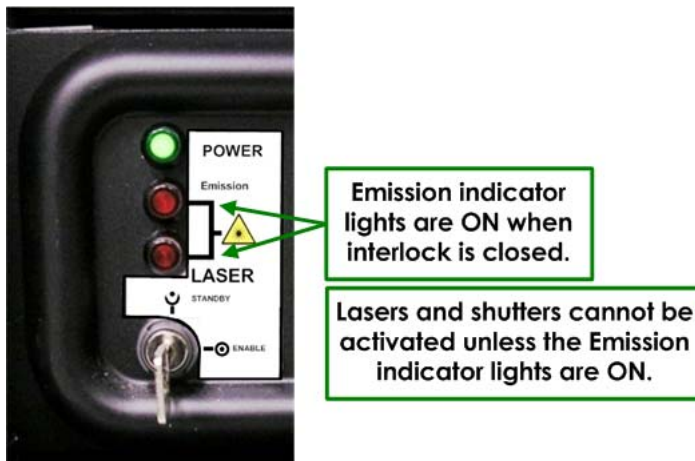

**Laser Source Key Switch**

- A Port Selector Interlock prevents laser output unless the Port Selector knob on the microscope stand is set to the **Camera** (left side port) position. This device prevents exposure to the beam while looking through the eyepieces.

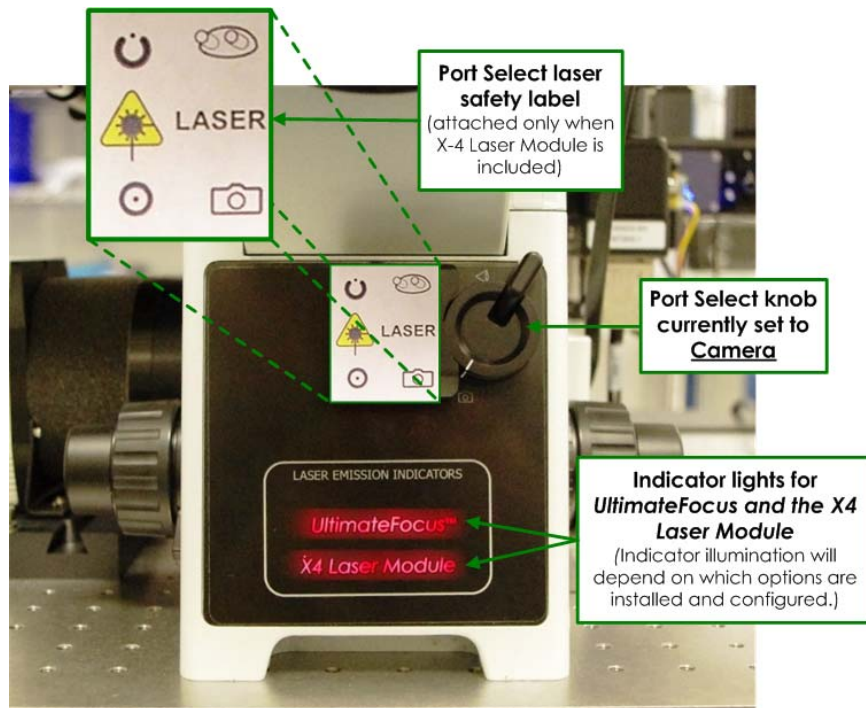

#### Port Selector Knob for Laser Module

- Indicator lights on the system illuminate when the lasers are powered on and the interlocks are closed. The lasers can be fired at any time when the system is in this state, so the lights warn users to take any necessary precautions. A pair of indicator lights is visible on the front of the Laser Source Chassis. Another pair of indicator lights is visible on the Port Selector switch. All lights should be OFF or ON at the same time in proper operation.
- A User Interlock Connector on the back panel of the Laser Source Chassis allows you to install a door interlock to prevent laser output when the door is open. When the door interlock is active, the lasers turn ON but cannot emit light past the shutter.
- If you are not using a remote interlock, you must insert Interlock Jumpers into the User Interlock Port and the Fiber1 Interlock Port. These jumpers must be in place for the lasers to emit light.



#### Interlock Jumpers

For the lasers to operate, all of the following safety devices must be set as follows:

- The Key Lock switch must be **On**.

- The Port Select knob must be set to the **Camera** position.
- The User Interlock Connector circuit must be closed.
- At least one of the fiber interlock circuits must be closed.

If any of these devices are not set as described above, the shutters between the laser heads and the fibers are prevented from opening.

## Avoiding Specific Hazards

The hazard of being exposed to the laser beam through the objective turret when no objective is in place can be mitigated by turning off the key lock switch on the front of the Laser Source Chassis prior to any system re-configuration or maintenance.

Specific hazards during alignment or system maintenance include:

- Exposure to the beam when disassembling the Fiber Optic Module from the microscope.
- Exposure to the beam when disassembling the Laser Optics Module from the Fiber Optic Module.
- Exposure to the beam when disassembling the optical fiber from the Laser Optics Module or the Laser Source Chassis.
- Exposure to the beam while the polychroic beam splitter turret is removed from the stand.

Radiation can be emitted as follows:

- **Through the objective.** The beam that comes through the objective is emitted during imaging experiments. It can be as powerful as 26mW and includes all wavelengths of lasers available in the Laser Source Chassis. The beam is highly divergent and depends on the objective used; using various GE-approved objectives, the divergence angle can be as low as 45 degrees or as high as 140 degrees. With the maximum power on all lasers, using the lowest-NA objective, the Nominal Optical Hazard Distance (NOHD) is less than 10cm (4 inches).
- **From the objective turret when no objective is in place.** This beam is only visible during maintenance (for example, when aligning the Laser Optics Module) or when the lasers are triggered accidentally without an objective being in place. This beam is collimated and small (a few mm across). The beam power may be as high as 30mW.
- **From the fluorescence illuminator when no polychroic is in place.** This beam is only visible during maintenance, when adding or removing cubes from the polychroic turret. This beam is collimated and small (a few mm across). The beam power may be as high as 45mW.

Whenever you use the X4 Laser Module, it is critical to keep your own safety and the safety of those around you a top priority. This is particularly important when maintaining the system, such as aligning the Optics Module or focusing the beam. ***Some maintenance tasks involve potential exposure to dangerous levels of laser radiation.*** According to ANSI Z135.1 (which is the standard the United States government uses for the safe use of lasers), the operator of a laser is responsible for the safety of everyone in the area, so you

must be aware of the risks and keep others in the area safe. Some basic precautions will dramatically reduce the potential for injuries and damage.



**WARNING:** USE OF CONTROLS OR ADJUSTMENTS OR PERFORMANCE OF PROCEDURES OTHER THAN THOSE SPECIFIED HEREIN MAY RESULT IN HAZARDOUS RADIATION EXPOSURE.

---



**WARNING!** EVEN IF ALL OF THESE PRECAUTIONS ARE TAKEN, A RISK OF INJURY CAN STILL EXIST.

---

### DURING USE:

- **Make sure the system is ready for use before enabling the lasers.** An objective should be in place and the polychroic turret should be installed. The indicator lights on the system (two small lights on or near the Port Selector Interlock, depending on whether or not the system includes the TruLight Illumination Module) and two more on the Laser Source Chassis) should be either all ON or all OFF.
- **Do not lean close to the objective** to view the sample or make adjustments to parts of the system, etc. while the laser is on.

### BEFORE BEGINNING MAINTENANCE:

- **Whenever possible, work with the lasers disabled,** for example, by turning the key to the "LASER STAND-BY" position.
- **When lasers must be used, begin work by reducing the beam power** as much as possible. Only increase the beam power if the work cannot be performed with lower laser power settings.
- **Do not turn the laser on until the entire beam path is safe.** Determine where the beam is going to go before turning on the laser and make sure the beam is blocked as soon as possible. Clear all reflective surfaces from the beam path—a reflected beam can be dangerous for several meters in many cases.
- **Be extremely vigilant about putting items in the beam path.** Tools, watches, rings and microscope samples can all make excellent reflective surfaces, and when inserted into the beam path, they can steer the beam in dangerous and unpredictable ways.
- **If anyone is in the room, brief them on the procedures to be performed and what hazards will be present.** Reiterate that the area may be dangerous and that they must comply with any instructions you give regarding safety.



**WARNING:** USE OF CONTROLS OR ADJUSTMENTS OR PERFORMANCE OF PROCEDURES OTHER THAN THOSE SPECIFIED HEREIN MAY RESULT IN HAZARDOUS RADIATION EXPOSURE.

---

## TIRF-specific Laser Safety Considerations

Due to the TIRF illumination optics provided by the TIRF Module and its laser component, the light being emitted from the DeltaVision objective is collimated and has high power density. The TIRF system also has the ability to direct this light to sharp, off-axis angles relative to the objective axis. Appropriate laser safety goggles selected for the specific wavelength being used are recommended.

## X4 Laser Module Safety Labeling

### Standard Configuration

#### Avoid Exposure Caution Label



CAUTION  
CLASS 3B VISIBLE AND INVISIBLE LASER RADIATION  
WHEN OPEN.  
AVOID EXPOSURE TO BEAM.

#### Avoid Exposure Label



AVOID EXPOSURE.  
VISIBLE AND INVISIBLE LASER RADIATION IS EMITTED  
FROM THIS APERTURE.

#### Avoid Exposure Label



CAUTION  
CLASS 3B VISIBLE AND INVISIBLE LASER RADIATION  
WHEN OPEN.  
AVOID EXPOSURE TO BEAM.



## Optional Configurations

### 405nm Laser Option Label

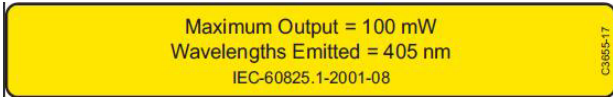

405nm Laser Option

$\lambda$  **max. power**

---

405nm **100mW**

### 445nm Laser Option Label

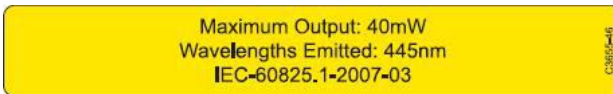

445nm Laser Option

$\lambda$  **max. power**

---

445nm **40mW**

### 488nm Laser Option Label

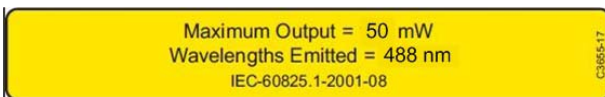

488nm Laser Option

$\lambda$  **max. power**

---

488nm **50mW**

### 514nm Laser Option Label



514nm Laser Option

$\lambda$  **max. power**

---

514nm **50mW**

### 561nm Laser Option Label



561nm Laser Option

$\lambda$  **max. power**

---

561nm **50mW**

### 640nm Laser Option Label

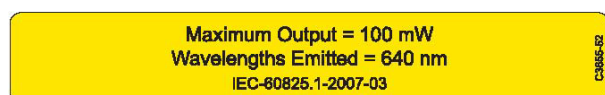

640nm Laser Option

$\lambda$  **max. power**

---

640nm **100mW**

## X4 Safety Label Locations

Laser Safety labels and notifications should be installed on the X4 Laser Module as illustrated below. In the event that a label is not installed or installed improperly, contact the appropriate Regional Technical Support. Contact information is available at the following website:

<http://www.api.com/2013support/>.

### X4 Laser Source Chassis

The following labels are placed on the front of the Laser Source Chassis.



**Note** Only safety labels that correspond to the laser(s) installed in the Laser Source Chassis will be present.

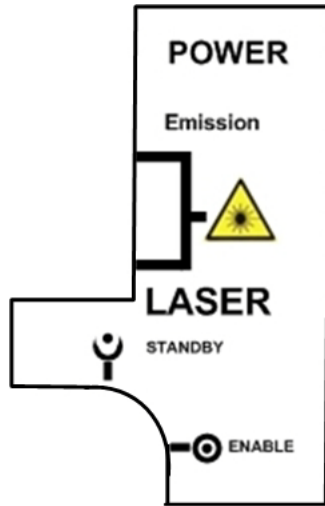

Laser Module Key Switch Safety Label



Primary Laser (488nm) Safety Label

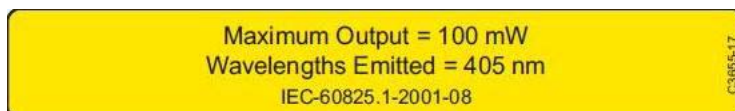

**405nm Laser Safety Label**



**514nm Laser Safety Label**



**561nm Laser Safety Label**



**640nm Laser Safety Label**

The following photos show the locations for the safety labels above to be placed on the front of the Laser Source chassis.



**Laser Module Key Switch Label Location**

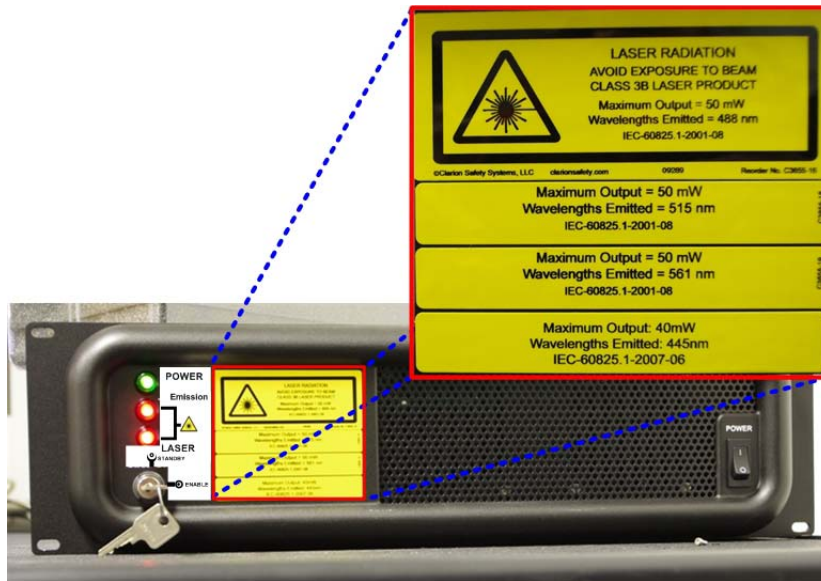

Laser Source Chassis Laser Safety Label Locations



**Note** Safety labels on the Laser Source Chassis will vary depending on which lasers are installed in your system.

## X4 Laser Optics Module

The X4 Laser Optics Module connects to the DeltaVision Fiber Optics Module on *non-TruLight* systems. The Laser Optics Module has the following laser safety label attached in two places on the module as shown.



Optics Module Laser Safety Label

One safety label is attached to the beam cover of the Optics Module as shown.



**Optics Module Safety Label (Location 1)**

The second safety label is attached to the upper portion (opposite side) of the Optics Module as shown.



**Optics Module Safety Label (Location 2)**

## DeltaVision Stage

The following safety label is placed on the edge of the DeltaVision stage as shown.



Laser Safety Label Location - DeltaVision Stage

## Polychroic Beam Splitter Removal Screw

The following label is placed on the side of the DeltaVision, next to the screw for removing the Polychroic Beam Splitter.



Polychroic Beam Splitter Removal Warning

This label warns users that, with the turret removed, laser radiation can come out through the fluorescence illuminator and be accessible. The label is attached to the DeltaVision as shown.



## CE Label

The CE Label for the X4 Laser Module is attached to the back of the Laser Source Chassis as shown.

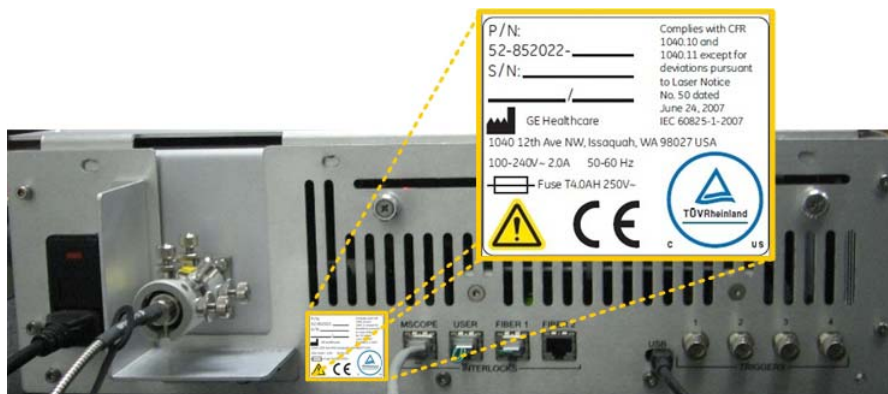

## Automated Fluorescence Illumination Module Safety

The Automated Fluorescence Illumination (Auto FI) Module is a modular system that allows you to attach several different laser wavelengths, visible and invisible, to the DeltaVision system. This section describes the hazards and precautions to take when using the Auto FI Module with lasers installed. These hazards and precautions must be fully reviewed and understood, and proper safety protocols must be followed during any use of the module, particularly those components which contain lasers.

## Important Safety Recommendations

A DeltaVision system configured with the Auto FI Module can incorporate up to four lasers, and is considered a Class 3B device. This means that laser radiation from the installed lasers can exit the device at the same time. The power level is high enough to cause damage to the human eye instantaneously.

The *UltimateFocus™* Module complies with CFR 1040.10 and 1040.11 except for deviations pursuant to Laser Notice No. 50, dated June 24, 2007 IEC 60825-1, 2007-03.

OSHA regulations require (via ANSI Z136.1) and IEC 60825-1 recommends that a Laser Safety Officer be identified who will be responsible for the safe use of Class 3B lasers at your site. This includes training users, installing all necessary warnings and controls in the laser area, and other duties.



### WARNING:

Given the inherent exposure possible with an inverted frame microscope stand, users of the system *must be trained in laser safety before using this instrument.*

Contact your lab administrator for information about Laser Safety training at your institution. Training is also available online at:

[www.kentek-laser.com/edu/lasercrs.htm](http://www.kentek-laser.com/edu/lasercrs.htm)

The International Electrotechnical Commission (IEC) and the FDA recommend that Class 3B and Class 4 lasers be used only in restricted areas.

## Safety Features

The Laser Module component of the Auto FI Module provides several features that control access to the device and improve its safety.

- The Key Lock switch on the front panel of the Laser Source Chassis must be in the **LASER ON** position to enable use of the lasers. The key can be removed only when this switch is in the **LASER STAND-BY** position.



Emission indicator lights are ON when interlock is closed.

Lasers and shutters cannot be activated unless the Emission indicator lights are ON.

Laser Module Key Switch

- A Port Selector Interlock prevents laser output unless the Port Selector knob on the microscope stand is set to the **Camera** (left side port) position. This device prevents exposure to the beam while looking through the eyepieces.



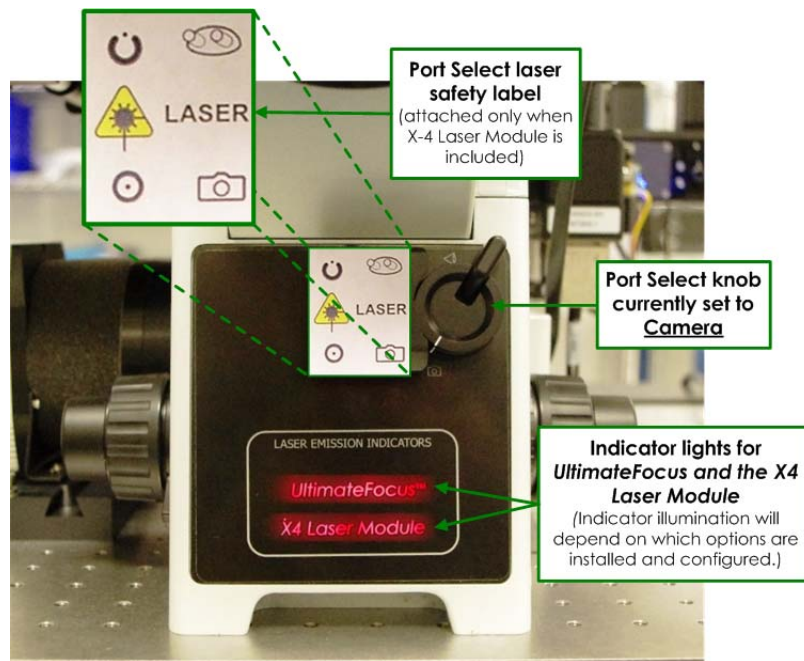

#### Port Selector Knob

- Indicator lights on the system illuminate when the lasers are powered on and the interlocks are closed. The lasers can be fired at any time when the system is in this state, so the lights warn users to take any necessary precautions. A pair of indicator lights is visible on the front of the Laser Source Chassis. Another pair of indicator lights is visible on the Port Selector switch. All lights should be OFF or ON at the same time in proper operation.
- A User Interlock Connector on the back panel of the Laser Source Chassis allows you to install a door interlock to prevent laser output when the door is open. When the door interlock is active, the lasers turn ON but cannot emit light past the shutter.
- If you are not using a remote interlock, you must insert
- Interlock Jumpers into the User Port and the Fiber1 Interlock Port. These jumpers must be in place for the lasers to emit light.



For the lasers to operate, all of the following safety devices must be set as follows:

- The Key Lock switch must be ON.
- The Port Select knob must be set to the **Camera** position.
- The User Interlock Connector must be closed.

- At least one of the fiber interlocks must be closed.

If any of these devices are not set as described above, the shutters (between the laser heads and the fibers) are prevented from opening.

## Avoiding Specific Hazards

The hazard of being exposed to the laser beam through the objective turret when no objective is in place can be mitigated by turning off the key lock switch on the front of the Laser Source Chassis prior to any system re-configuration or maintenance.

Specific hazards during alignment or system maintenance include:

- Exposure to the beam when servicing the Fiber Optic Module from the microscope.
- Exposure to the beam when servicing the Laser Optics Module from the Fiber Optic Module.
- Exposure to the beam when servicing the optical fiber from the Laser Optics Module or the Laser Source Chassis.
- Exposure to the beam while the polychroic beam splitter turret is removed from the stand.

Radiation can be emitted as follows:

- **Through the objective.** The beam that comes through the objective is emitted during imaging experiments. It can be as powerful as 26mW and include all wavelengths of lasers available in the Laser Source Chassis. The beam is highly divergent and depends on the objective used; using various GE-approved objectives, the divergence angle can be as low as 45 degrees or as high as 140 degrees. With the maximum power on all lasers, using the lowest-NA objective, the Nominal Optical Hazard Distance (NOHD) is less than 10 cm (4 inches).



**WARNING:** When using low NA air objectives (anything below 0.45 NA), the *UltimateFocus* laser beam does not diverge as much as it does with higher NA objectives. The beam, a Class 3B Invisible Laser light up to 2.2mW, is nearly collimated and is emitting straight up through the objective. Whenever the Laser Emission Indicators show that *UltimateFocus* is on, users must not look down the objective turret.

---

- **From the objective turret when no objective is in place.** This beam is only visible during maintenance (for example, when aligning the Laser Optics Module) or when the lasers are triggered accidentally without an objective being in place. This beam is collimated and small (a few mm across). The beam power may be as high as 30mW.
- **From the fluorescence illuminator when no polychroic is in place.** This beam is only visible during maintenance, when adding or removing cubes from the polychroic turret. This beam is collimated and small (a few mm across). The beam power may be as high as 45mW.

Whenever you use any of the DeltaVision lasers, it is critical to keep your own safety and the safety of those around you a top priority. This is particularly important when maintaining the system, such as aligning the Optics Module or focusing the beam. **Some**

***maintenance tasks involve potential exposure to dangerous levels of laser radiation.***

According to ANSI Z135.1 (which is the standard the United States government uses for the safe use of lasers), the operator of a laser is responsible for the safety of everyone in the area, so you must be aware of the risks and keep others in the area safe. Some basic precautions will dramatically reduce the potential for injuries and damage.



**WARNING:** USE OF CONTROLS OR ADJUSTMENTS OR PERFORMANCE OF PROCEDURES OTHER THAN THOSE SPECIFIED HEREIN MAY RESULT IN HAZARDOUS RADIATION EXPOSURE.

---



**WARNING!** EVEN IF ALL OF THESE PRECAUTIONS ARE TAKEN, A RISK OF INJURY CAN STILL EXIST.

---

**DURING USE:**

- **Make sure the system is ready for use before enabling the lasers.** An objective should be in place and the polychroic turret should be installed. The indicator lights on the system (two small lights on the Port Selector Interlock and two more on the Laser Source Chassis) should be either all ON or all OFF.
- **Do not lean close to the objective** to view the sample or make adjustments to parts of the system, etc. while the laser is on.

**BEFORE BEGINNING MAINTENANCE:**

- **Whenever possible, work with the lasers disabled,** for example, by turning the key to the “LASER STAND-BY” position.
- **When lasers must be used, begin work by reducing the beam power** as much as possible. Only increase the beam power if the work cannot be performed with lower laser power settings.
- **Do not turn the laser on until the entire beam path is safe.** Determine where the beam is going to go before turning on the laser and make sure the beam is blocked as soon as possible. Clear all reflective surfaces from the beam path—a reflected beam can be dangerous for several meters in many cases.
- **Be extremely vigilant about not putting items in the beam path.** Tools, watches, rings and microscope slides can all create excellent reflective surfaces, and when inserted into the beam path, they can steer the beam in dangerous and unpredictable ways.
- **If anyone is in the room, brief them on the procedures to be performed and what hazards will be present.** Reiterate that the area may be dangerous and that they must comply with any instructions you give regarding safety.

- Always wear appropriate laser safety goggles.



**WARNING:** USE OF CONTROLS OR ADJUSTMENTS OR PERFORMANCE OF PROCEDURES OTHER THAN THOSE SPECIFIED HEREIN MAY RESULT IN HAZARDOUS RADIATION EXPOSURE.

---

## TIRF-specific Laser Safety Considerations

Due to the TIRF illumination optics provided by the TIRF/PK Module and its laser component, the light being emitted from the DeltaVision objective is collimated and has high power density. The TIRF system also has the ability to direct this light to sharp, off-axis angles relative to the objective axis. When using the TIRF system, use extreme caution that the emitted light is not directed into the user's eyes. Always wear appropriate laser safety goggles selected for the specific wavelength being used.

# Auto FI Safety Labeling

## Standard Configuration

### Avoid Exposure Caution Label

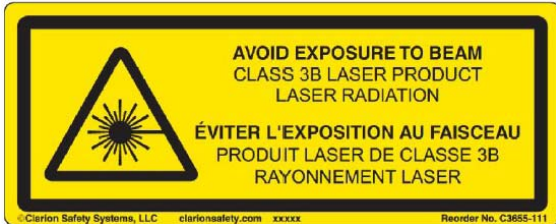

CAUTION  
 CLASS 3B VISIBLE AND INVISIBLE LASER RADIATION WHEN OPEN.  
 AVOID EXPOSURE TO BEAM.

### Avoid Exposure Label



CAUTION  
 CLASS 3B VISIBLE AND INVISIBLE LASER RADIATION WHEN OPEN.  
 AVOID EXPOSURE TO BEAM.



LASER MODULE KEY SWITCH SAFETY LABEL.

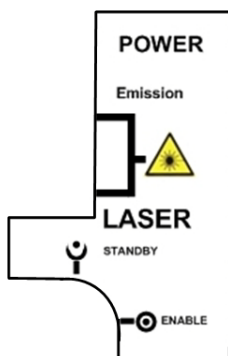



## Safety Label Locations

Laser Safety labels and notifications should be installed on the Auto FI Module as illustrated below. In the event that a label is not installed or installed improperly, contact the appropriate Regional Technical Support. Contact information is available at the following website:

<http://www.api.com/2013support/>.

### Laser Source Chassis

The following labels are placed on the front of the Laser Source Chassis.

---

 **Note** Only safety labels that correspond to the laser(s) installed in the Laser Source Chassis will be present.

---

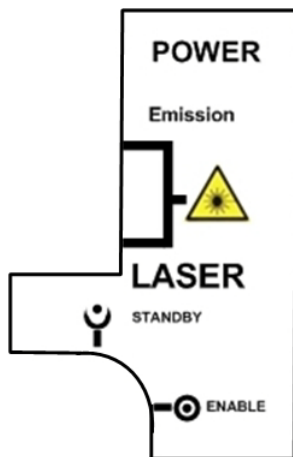

Laser Module Key Switch Safety Label



Primary Laser Safety Label

**Maximum Output = 100 mW      Wavelength = 640 nm**  
**Puissance émise maximale      Longueur d'onde**

640nm Laser Safety Label

**Maximum Output = 50 mW**      **Wavelength = 568 nm**  
**Puissance émise maximale**      **Longueur d'onde**

**Maximum Output = 150 mW**      **Wavelength = 568 nm**  
**Puissance émise maximale**      **Longueur d'onde**

568nm Laser Safety Labels (50 or 150mW)

**Maximum Output = 50 mW**      **Wavelength = 514 nm**  
**Puissance émise maximale**      **Longueur d'onde**

514nm Laser Safety Label

**Maximum Output = 50 mW**      **Wavelength = 488 nm**  
**Puissance émise maximale**      **Longueur d'onde**

**Maximum Output = 100 mW**      **Wavelength = 488 nm**  
**Puissance émise maximale**      **Longueur d'onde**

488nm Laser Safety Labels (50 or 100mW)

**Maximum Output = 100 mW**      **Wavelength = 445 nm**  
**Puissance émise maximale**      **Longueur d'onde**

445nm Laser Safety Label

**Maximum Output = 100 mW**      **Wavelength = 405 nm**  
**Puissance émise maximale**      **Longueur d'onde**

405nm Laser Safety Label

The following photos show the locations for the safety labels above to be placed on the front of the Laser Source chassis.



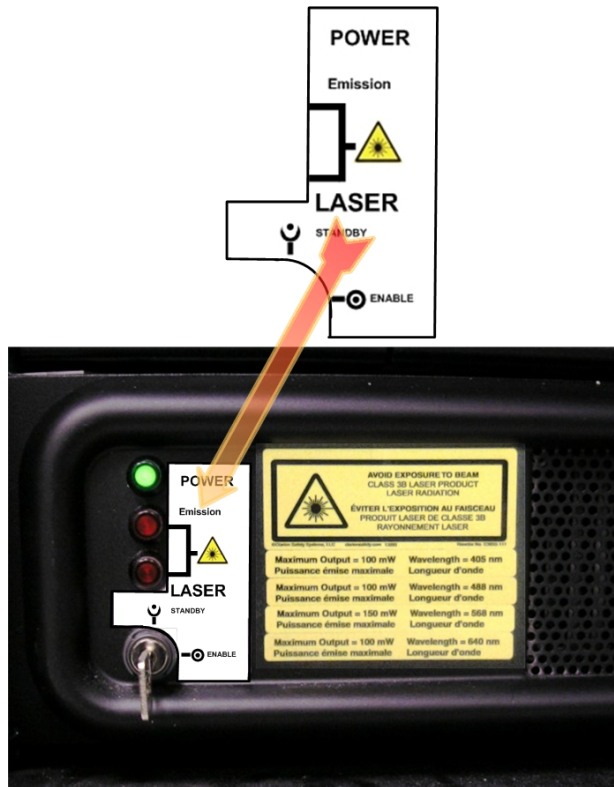

Laser Module Key Switch Label Location



Laser Source Chassis Laser Safety Label Locations







**Note** Safety labels on the Laser Source Chassis will vary depending on which lasers are installed in your system.

## Laser Safety Labels with Auto FI Module



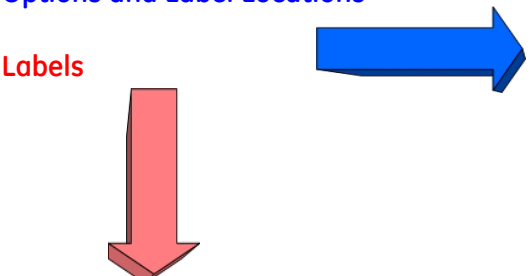

Depending on how the Auto FI Module is configured, it can result in adding several different visible and invisible laser wavelengths to the standard DeltaVision system. Since the different options available with this module are so many and varied, you should consult the following table to determine the location and type of Laser Safety Labels that should be attached to a particular system.

The following table shows the location and type of Laser Safety Labels, depending on the various options installed, that should be attached to a system equipped with the TruLight Module. Use this table in conjunction with the illustrations immediately following, in which the label positions are called out by number.

### Auto FI Module Laser Safety Label Types and Locations on DeltaVision systems (labels in French for Canadian compliance)

<p><b>Options and Label Locations</b></p> <p><b>Labels</b></p> 	<p><b>X4</b></p>	<p><b>Ultimate Focus™</b></p>	<p><b>X4 and Ultimate Focus™</b></p>	<p><b>Localization</b></p>
<p><b>Visible Laser Warning</b></p> 	<p><b>9</b></p>			
<p><b>Invisible Laser Warning</b></p> 		<p><b>9</b></p>		
<p><b>Visible and Invisible Laser Warning</b></p> 			<p><b>9</b></p>	



<p><b>Invisible Laser Radiation, Class 3R</b></p> <p>English:</p>  <p>French:</p> 	<p>2</p>	<p>2</p>	
<p><b>Class 3B Visible and Invisible when Open</b></p> <p>English:</p>  <p>French:</p> 	<p>3</p>	<p>3</p>	

<p>Port Select Laser Safety Label</p> 	<p>13</p>	<p>11</p>	<p>13</p>
---	-----------	-----------	-----------

\*Label is present only when the Ultimate Focus Module is not installed.

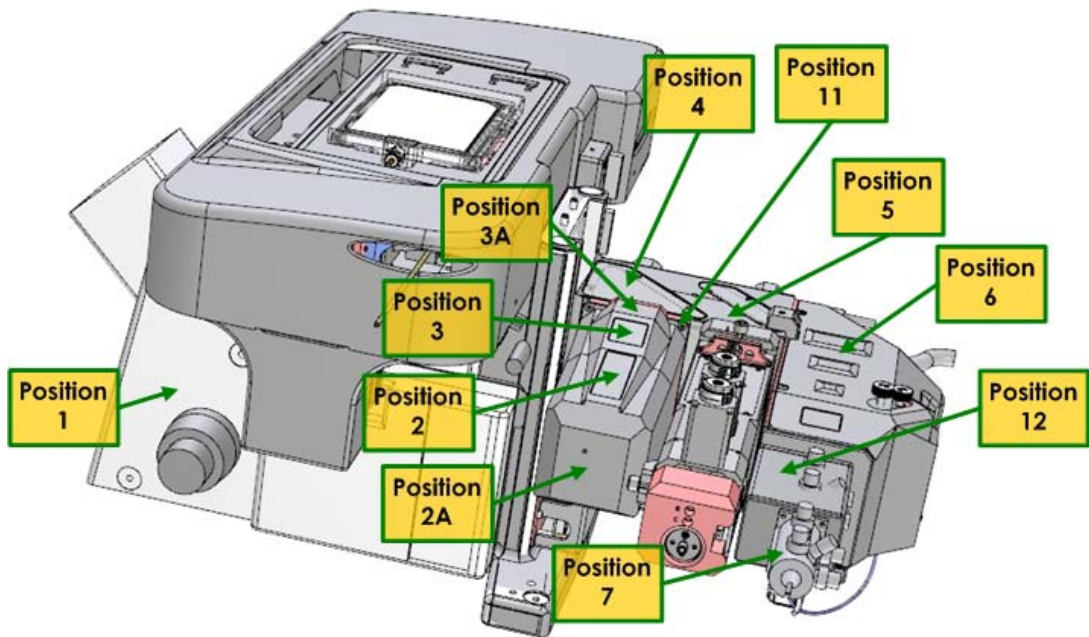

Laser Safety Label Locations (as viewed from the right rear of the system)

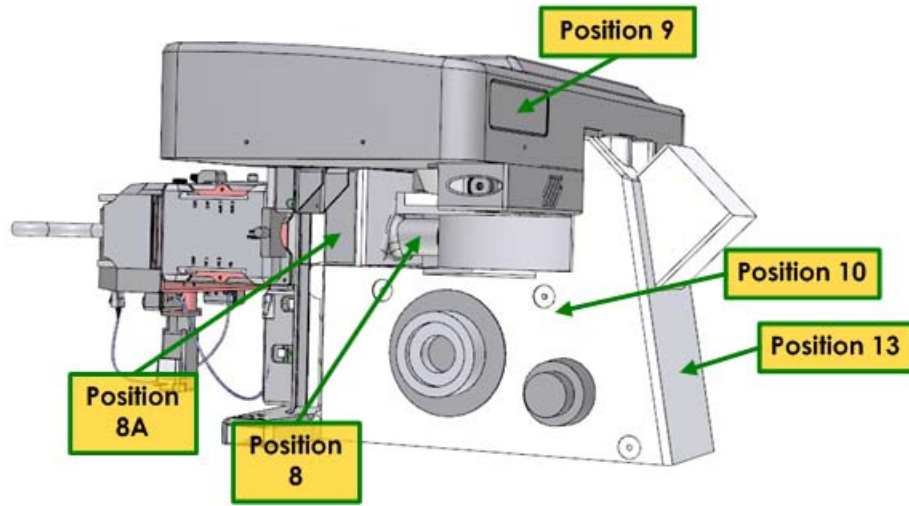

Laser Safety Label Locations (as viewed from the left front of the system)

## DeltaVision Stage

The following label is placed on the edge of the DeltaVision stage as shown.

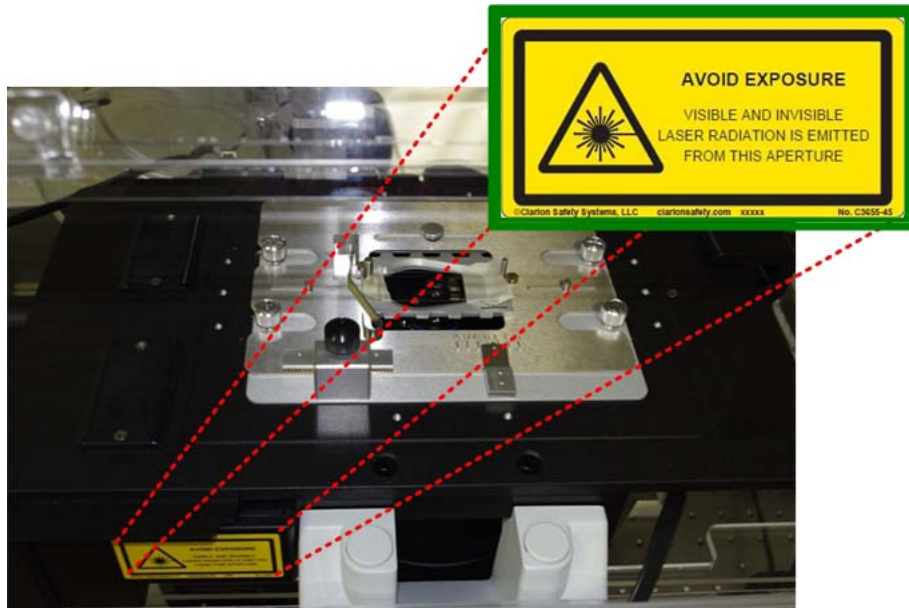

Laser Safety Label Location - DeltaVision Stage

## CO<sub>2</sub> Chamber / TIRF Cover

The following label is placed on the CO<sub>2</sub> Chamber and TIRF Cover as shown.

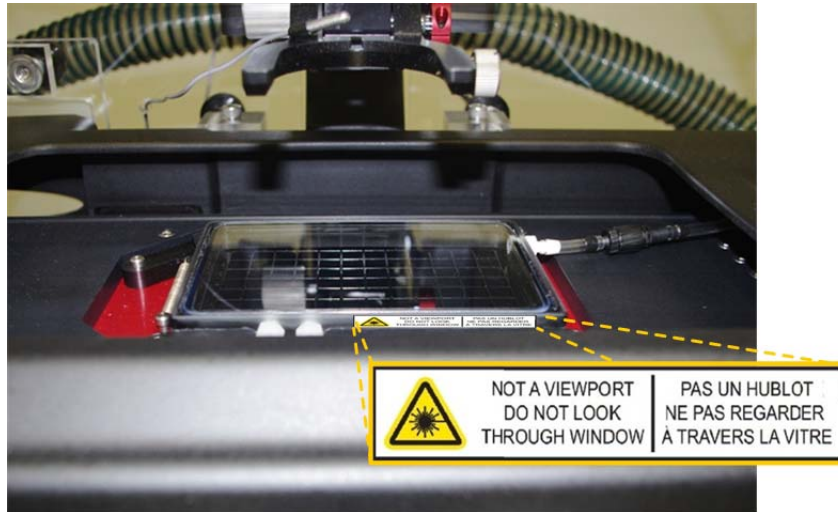

### Laser Safety Label Location - CO<sub>2</sub> Chamber and TIRF Cover

(Label is placed on the edge of the chamber.)



**WARNING!** DO NOT use the system for TIRF imaging without this cover in place.

## Labels for Polychroic Turret Removal

The following label is placed on the right side of the DeltaVision, next to the screw for removing the Polychroic Turret. This label warns users that, with the turret removed, laser

radiation can be accessible coming out through the fluorescence illuminator. The label is attached to the DeltaVision as shown.

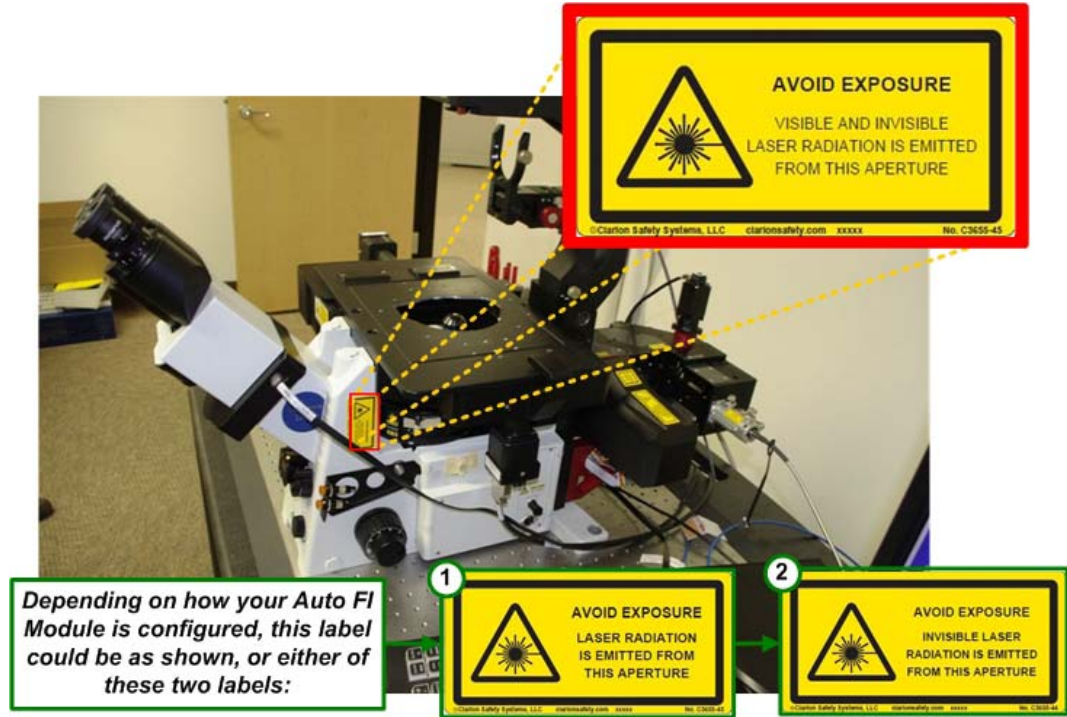

## X4 Module Laser Launch Safety Labels

The following labels are placed on the rear of the X4 Module as shown in the photo below.

English



French





(This view is shown from the top of the X4 Module, looking down at the labels.)



## Compliance Labels

The CE Label for the X4 Laser Module is attached to the back of the Laser Source Chassis as shown.

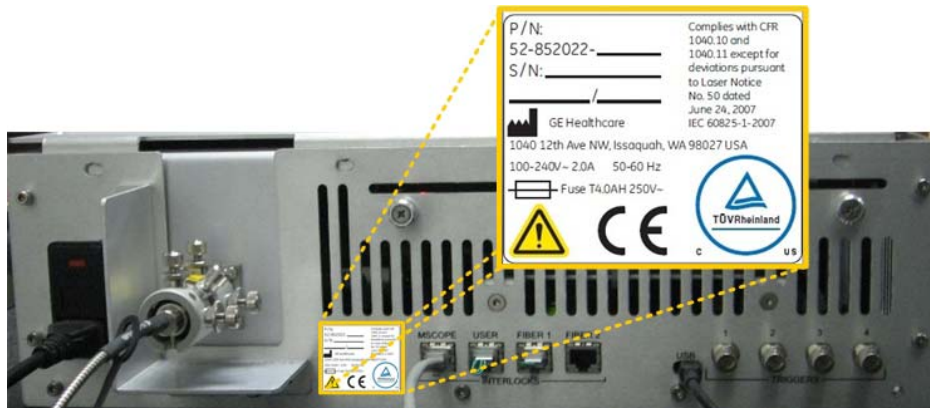

**X4 Laser Module - CE Label**

The Compliance Label for the *UltimateFocus™* Module is attached to the back of the DeltaVision Microscope as shown.

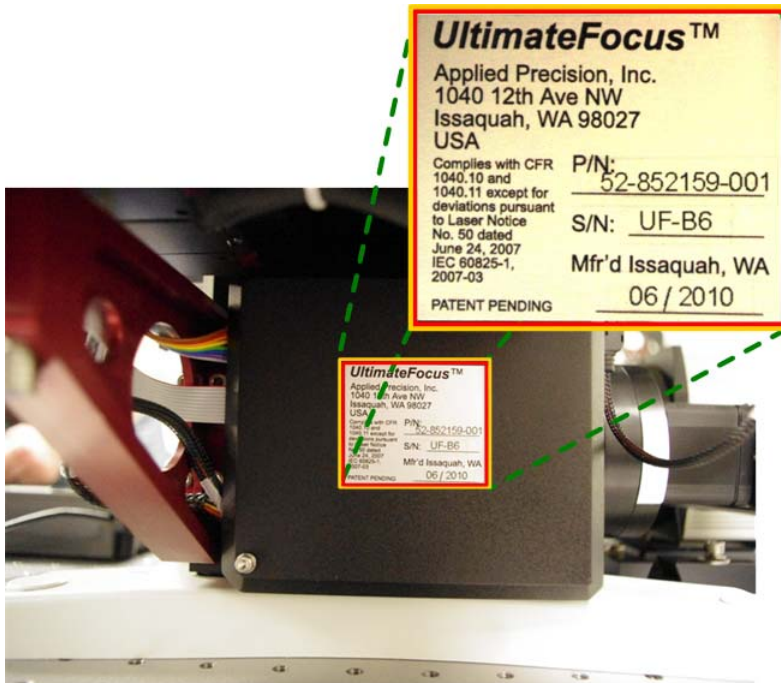

UltimateFocus™ Compliance Label

# Appendix G. DeltaVision - Declaration of Hazardous Substances (DoHS)

The following information answers to the Chinese Standard SJ/T11363-2006.



该标志表明本产品含有超过 SJ/T11363-2006 《电子信息产品中有毒有害物质的限量要求》中限量的有毒有害物质。标志中的数字为本产品的环保使用期，表明本产品在正常使用的条件下，有毒有害物质不会发生外泄或突变，用户使用本产品不会对环境造成严重污染或对其人身、财产造成严重损害的期限，单位为年。

为保证所声明的环保使用期限，应按产品手册中所规定的环境条件和方法进行正常使用，并严格遵守产品维修手册中规定的定期维修和保养要求。

产品中的消耗件和某些零部件可能有其单独的环保使用期限标志，并且其环保使用期限有可能比整个产品本身的环保使用期限短。应到期按产品维修程序更换那些消耗件和零部件，以保证所声明的整个产品的环保使用期限。

本产品在使用寿命结束时不可作为普通生活垃圾处理，应被单独收集妥善处理。

This symbol indicates the product contains hazardous materials in excess of the limits established by SJ/T11364-2006 Marking for Control of Pollution caused by Electronic Information Products. The number in the symbol is the Environment-friendly Use Period (EFUP), which indicates the period during which the toxic or hazardous substances or elements contained in electronic information products will not leak or mutate under normal operating conditions so that the use of such electronic information products will not result in any severe environmental pollution, any bodily injury or damage to any assets, the unit of the period is "Year".

In order to maintain the declared EFUP, the product shall be operated normally according to the instructions and environmental conditions as defined in the product manual, and periodic maintenance schedules specified in Product Maintenance Procedures shall be followed strictly. Consumables or certain parts may have their own label with an EFUP value less than the product. Periodic replacement of those consumables or parts to maintain the declared EFUP shall be done in accordance with the Product Maintenance Procedures.



标志表明本品不含有超 中国标准 SJ/T11363-2006 《电子信息产品中有毒有害物质的限量要求》中限量的有毒有害物质，后可以行回收理，不能随意弃。

This symbol indicates that this electronic information product does not contain any toxic or hazardous substances or elements above the maximum concentration value established by the Chinese standard SJ/T11363-2006, and can be recycled after being discarded, and should not be casually discarded.

O: 表示该有毒有害物质在该部件所有均质材料中的含量均在 SJ/T11363-2006 标准规定的限量要求以下  
 X: 表示该有毒有害物质至少在该部件的某一均质材料中的含量超出 SJ/T11363-2006 标准规定的限量要求

- 此表所列数据为发布时所能获得的最佳信息
- 由于缺少经济上或技术上合理可行的替代物质或方案，此医疗设备运用以上一些有毒有害物质来实现设备的预期临床功能，或给人员或环境提供更好的保护效果。

O: Indicates that this toxic or hazardous substance contained in all of the homogeneous materials for this part is below the limit requirement in SJ/T11363-2006.  
 X: Indicates that this toxic or hazardous substance contained in at least one of the homogeneous materials used for this part is above the limit requirement in SJ/T11363-2006.

- Data listed in the table represents best information available at the time of publication
- Applications of hazardous substances in this medical device are required to achieve its intended clinical uses, and/or to provide better protection to human beings and/or to environment, due to lack of reasonably (economically or technically) available substitutes.

部件名称 Component Name	有毒有害物质或元素 Hazardous substances' name					
	铅 (Pb)	汞 (Hg)	镉 (Cd)	六价铬 (Cr6+)	多溴联苯 (PBB)	多溴二苯醚 (PBDE)
Printed Circuit Board Assemblies	0	0	0	0	0	0
Power Supplies	0	0	0	0	0	0
Cables	0	0	0	0	0	0
Mechanical Assemblies	0	0	0	0	0	0
Enclosures	0	0	0	0	0	0
Microscope Assembly	0	0	0	0	0	0
Table Assembly	0	0	0	0	0	0



# Index

## Symbols

7.36  
%T Filter field E.19

## Numerics

2D Z projections 5.8  
3D images 1.4, 4.3

## A

Acquire Image button E.44, E.47  
Acquire image button 3.6  
Acquire images 3.15, 3.16, 3.17  
Acquire Mode arrows E.47  
Actions tab  
    with time-lapse experiments 4.20, 4.21, 4.22, 4.23, 4.24  
Active filter sets button 9.12  
Active Wavelength buttons E.19  
Adaptive time intervals 8.46  
Add log note action 4.24  
Add note to log field 4.28, 7.16  
Adjust channels independently 8.43  
AF button 4.13  
Air filter 8.36, 8.37  
Air flow 8.33  
Air objective 7.19  
Airflow  
    flowmeter 8.34  
Alconox 8.33  
Alignment  
    light path 8.19  
Altitude requirements 8.4  
Ambient illumination 8.4  
Analysis workstation 8.47  
API FI *see* API Fluorescence Illumination Module  
API FI *see* Applied Precision fluorescence illuminator  
Appliance coupler 8.3  
Applied Precision fluorescence illuminator 8.7, 8.9  
Applied Precision, Inc.  
    Legal notices  
        Copyright 0.ii  
        Registered trademarks 0.ii  
        Trademarks 0.ii  
Auto color mode 7.10  
Auto grayscale mode 7.9, 7.10  
Auto histogram range 7.11, E.31  
Auto intensity scale E.32  
Auto-determine parameters check box 4.26  
Autofocus  
    before acquiring points 5.2  
    before imaging E.22, E.24

    exposure 7.28  
    frequency 7.25, 7.26  
    in experiment macros 5.1, 5.2  
    introduction 1.5  
    options E.37  
    sampling range 8.38  
    setting in Resolve3D E.11  
    Z test step 4.26  
Autofocus action 4.23  
Autofocus action options window 4.25  
Autofocus before imaging option 5.2  
Autofocus options button 5.2  
Autofocus Z test step option E.37  
Automated optical sectioning 1.3  
Automatic switching 7.6  
Automatically determine parameters options 5.3  
Axial frequency C.5

## B

Bead slides C.4  
Beads  
    finding for PSF measurement C.4  
    measuring in immersion oil C.4  
Beam conditioner 8.9  
Bibliography 3.2  
Bin setting E.9  
Blank Screen button E.47  
Bleach event motion field 4.24  
Border rolloff C.7  
    determining 4.30  
Border rolloff voxels 4.30  
Bottom of sample 4.6, 5.12  
Bottom of sample setting E.11  
Brightfield 1.3  
Broadband light source 8.18, 8.19  
Broadband module 8.9  
Broadband neutral density filter holder 8.10, 8.11, 8.13, 8.14, 8.16, 8.18  
Bulbs 8.66  
Bulls eye level 8.28

## C

Cabinet components 8.1, 8.25  
Calculate statistics 7.11  
Calculating OTF *See* Optical transfer function  
Calculating pixel size C.2  
Calibrating filter wheels 9.12, 9.13, 9.14, 9.15  
Camera  
    changing 9.1–9.3  
    damage prevention 2.5  
    EM CCD 7.4  
    EMCCD 9.3  
    evolve 8.29

- high-speed 7.4
  - saturation 7.4, B.4
  - selecting 9.2–9.3
  - setting in Resolve3D E.34
  - Camera mode 3.10
  - Camera not found message B.2
  - Camera readout mode field 4.22
  - Cell culture plates 7.19
  - Cell mitosis 4.19
  - Cell track action 4.23
  - Cell tracking 5.3
    - guidelines 5.6
    - using 5.4
  - Cell tracking options window 4.26, 5.5
  - Cellular imaging courses 3.2
  - Center an image 3.16
  - Center object E.10
  - Center of geometry 5.6
  - Center of intensity 5.6
  - Change time-lapse action 4.24, 4.27
  - Changing cameras 9.1–9.3
  - Channel for autofocus field 4.26, 7.27
  - Channel for Autofocus setting E.37
  - Chinese hazardous substance standards G.1
  - Choosing filters 3.4
  - Class 3B device F.2
  - Cleaning DeltaVision 10.10
  - Clear thumbnails button 3.17
  - CO<sub>2</sub> chamber 8.35
  - Coarse angle adjustments 8.44
  - Coarse focus 3.4, 3.11, 3.13
  - Collect Panels setting E.25
  - Collect panels setting 4.31
  - Collecting data 7.1
  - Collecting panel images 4.30
  - Colocalization 8.47
  - Command line interface E.4
  - Components 8.1
    - cabinet 8.25
    - desktop 8.23
    - DIC 8.47
    - environmental chamber 8.29, 8.31
    - fiber optic module 8.8
    - fluorescence microscope 8.6
    - fuses 8.66
    - instrument controller 8.26
    - microtiter stage 8.29
    - optical 8.7
    - optional 8.29–8.65
    - optional software 8.47
    - photo sensor 8.20
    - power switches 10.2
    - repeatable slide holder 8.26, 8.27
    - software 8.28
    - softWoRx Workstation 8.26
    - tool kit 8.28
    - UltimateFocus 8.46
    - workstations 8.47
  - Condensation B.3
  - Condenser centering knobs 8.53
  - Condenser DIC prism 8.48
  - Condenser polarizer 8.54, 8.59, 8.62
  - Condenser polarizer slider 8.50
  - Condenser prism turret 8.50, 8.62
  - Consumable parts 8.1, 8.66
  - Continuous acquire 8.53, 8.59, 8.64, E.3
  - Contrast calculation method field 4.26
  - Contrast calculation polarity E.37
  - Control Mode button E.46
  - Controlling the stage E.10
  - Conventions
    - User interface 0.iii
  - Converting PSF to OTF C.5
  - CoolSNAP ES2 camera 8.11
  - CoolSNAP ES2 CCD camera 8.16
  - CoolSNAP HQ2 camera 8.11
  - Country-specific requirements 8.3
  - Critical illumination 1.5, 7.5, 7.5–7.8
    - selecting 8.9
  - Critical illumination position 7.7
  - Critical illumination spring 7.5
  - Crossing polarizers 8.53
  - Custom action 4.24, 4.29
  - Custom filter sets 8.38
  - Custom filter wheels 9.3–9.4
- ## D
- Damage prevention 2.5
  - Data
    - collection techniques 7.1
    - monitoring acquisition of 7.8
    - saving 3.17
  - Data collection
    - window 3.10
  - Data collection options 1.4
  - Data Management Software 8.26
  - Data storage B.2
  - Deconvolution previews 7.8–7.9
  - Deconvolve preview images E.31
  - Default filters 4.10
  - Delete point button 4.14
  - DeltaVision
    - capabilities 1.3
    - components 8.1
  - Depth of field 4.7
  - Design tab 4.1, 4.5
  - Design/Run Experiment window E.15
  - Desktop components 8.1, 8.23

- Diagnosing system problems B.1–B.2
- DIC 5.11, 8.7, 8.30, 8.47
  - aligning 8.50
  - controls 8.49
  - installing 8.49
  - optics 8.48
  - overview 8.50
  - setup 8.61–8.66
- DIC condenser 8.53
- Differential interface contrast 8.30
- Differential Interference Contrast See DIC
- Differential Interference Contrast See DIC
- Digital microscopy 1.3
- Dim illumination problems B.3
- Dim image problem B.3
- Disable Motion keys E.47
- Disposal procedure 2.5
- Distance from coverslip A.1
- Distorted images B.3
- DMS 8.26, 8.47
- Do autofocus check box 7.26
- Do microtiter plate scanning check box 7.25
- Door interlock F.3
- Duration field 4.24
- Dust B.3, B.4
- Dust issues 8.5
  
- E**
- Editing a point list 4.14
- Editing macros 7.11
- Electric supply
  - rating 8.2
- Electrical requirements 8.1, 8.2
- Electromagnetic environment 2.4
- EMCCD camera 9.3
- EMCCD-type camera 8.17
- Emission filter
  - changing 9.7–??, 9.7–9.9, ??–9.9
  - picture 9.4
- Emission filter wheel
  - orientation 8.53
  - removal 8.56
- Emission filters 3.13, 4.10
  - specifications D.2
- Emission indicator lights F.2
- Emission polarizer 8.53, 8.54, 8.59, 8.62
- Empty filter modules 8.38
- Empty filter wheels 9.4
- Enable cell tracking check box 5.4
- Enable cell tracking option 5.3
- Enable fast acquisition E.17
- Encoder error B.2
- End of scan E.11
- Enlarge a thumbnail image 3.16
  
- Environmental chamber 8.29, 8.31
- Environmental requirements 8.1, 8.3
- Epifluorescence button 8.44
- Epifluorescence inverted microscope 8.7
- Ethanol 8.33
- Evanescent field 8.9
- Evanescent wave 8.41
- Event pattern field 4.25
- Evolve camera 8.17, 8.29
- Ex filter field E.19
- Ex shutter button 3.6, E.44, E.48
- Ex shutter field E.20
- Excitation filter
  - changing 9.5–9.7
  - picture 9.4
- Excitation filters 3.5, 3.13, 4.10
  - specifications D.2
- Excitation shutter
  - safety 3.15
- Exp field E.19
- Experiment button 7.14
- Experiment macro editor 7.11
- Experiment macros 4.1, 5.1, 5.2
- Experiment name field 4.2
- Experiments
  - 3D 4.3
  - and autofocus macros 5.1
  - and focal planes 4.6
  - and marking points 4.11
  - and optical section spacing 4.7
  - and panel collection 4.30
  - editing macros for 7.11
  - guidelines for 3D 4.6
  - macros folders E.33
  - photokinetic 8.39
  - point visiting 4.10
  - running 4.1
  - setting up 4.1
  - time-lapse 4.19, 5.3
- Explorer 8.47
- Exposure time 7.4
- Exposure values 4.10
- Eyepiece
  - filter wheel 3.13
  - filter wheel and safety 2.3
  - filters 3.5
  - focus 3.4
  - removal 8.54
- Eyepiece filter
  - changing 9.9–9.10
  - picture 9.4
- Eyepiece polarizer 8.57, 8.60, 8.61, 8.62

## F

- Facility requirements 8.1
- Fan control 8.33
- Fast acquisition check box 4.21
- Fast acquisition options window 4.21
- Fast button 3.7, E.45, E.47
- Fiber interlocks F.4
- Fiber optic module 8.8
- Fiber1 interlock port F.3
- Field stop aperture 8.9
- File extensions D.1
- File system full error B.2
- Filter box 8.36, 8.37
- Filter monitor 3.10
- Filter monitor window 3.14
- Filter wheels
  - changing 9.4–9.12
- Filters
  - alignment B.3
  - and changing wheels 9.5
  - and safety 2.3
  - and wheel modules 9.5
  - calibrating 9.12, 9.13, 9.14, 9.15
  - changing emission wheel 9.7
  - choosing 3.4
  - cleaning 10.10
  - custom 8.38
  - default 4.10
  - emission 3.5
  - excitation 3.5
  - excitation and emission peaks D.2
  - eyepiece 3.5
  - eyepiece wheel change 9.9
  - fluorescence D.2
  - home position 9.14
  - live cell sets D.2, D.3
  - neutral density 3.5
  - optional modules for 8.38
  - specifications D.2
  - standard optical 8.7
- Find a sample 3.14, 3.15
- Find exposure E.9
- Finding a sample 7.1
- Finding exposure time 7.4
- Fine angle adjustments 8.44
- Fine focus 3.4
- Flat-panel LCD monitor 8.23
- Flowmeter 8.34
- Fluorescence 1.3
- Fluorescence microscope 8.6, 8.7
- Fluorescence recovery after photo-bleaching 8.29
- Fluorophores 8.41
- Focal planes 4.6, 4.7
- Focus 3.4

- coarse Z 3.4
- fine Z 3.4

- Focus lock 3.4
  - release 3.8
- Focus point 4.5, 4.6
- Folder button 7.34
- FOM
  - in critical position 7.7
  - in Kohler position 7.8
- Fourier transform C.5
- Frames to average setting E.34
- FRAP analysis 8.29
- Fuses 2.5, 8.2
  - replacing 10.9

## G

- Gain setting E.34
- Generate plate point List 7.31
- Get Thickness setting E.18
- Goodwin, Paul 1.2
- Graph
  - ratio 7.17
- Graph, ratio 4.28
- Guidelines for 3D experiments 4.6

## H

- Heat switch 8.33
- Hex wrench set 8.28
- Higher capacity isolation 8.24
- High-speed CCD camera 8.11
- Histogram 7.10, 7.11
- Histograms E.14
- Home filter position 9.14
- Humidifier 8.31, 8.33
- Humidity requirements 8.4
- Hysteresis 7.25

## I

- IC/MIC 8.1, 8.25
  - fuse for 8.66
  - part number 8.66
  - power switch 10.2
  - replacing fuses 10.9
- IC/MIC switches 10.2
- Illumination
  - always critical 7.6
  - always kohler 7.6
  - ambient 8.4
  - exposure time 7.4
  - solid state 8.9
  - switching between modes 7.5, 7.6
  - types of 7.5
- Illumination path alignment 8.19



- Illumination switching 7.6
- Image
  - contrast 7.25
- Image acquisition 3.15
  - and exposure time 7.4
  - and live specimens 5.1
  - collecting panels for 4.30
  - exposure time 7.4
  - marking points for 4.11
  - monitoring 7.8
  - point visiting 4.10
  - troubleshooting B.2
  - with continuous Z sweep 5.8
- Image control fields E.7
- Image display and analysis 1.4
- Image display mode 7.10
- Image intensity E.14
- Image processing
  - reference material D.10
- Image scan sequence field 4.21
- Images
  - 3D 4.3
  - acquiring 3.15
  - and optical section spacing 4.7
  - calibrate E.9
  - collecting panels for 4.30
  - distortion B.3
  - intensity values E.14
  - live cell 1.5, 5.1
  - ratio 7.13
  - reference 5.11–5.13
  - running experiments for 4.1
  - saving 3.17
  - scale values E.14
  - setting size E.9
  - symmetric flare C.5
  - viewing previews 7.8
- Immersion oil
  - air bubble B.4
  - selecting C.4
  - temperature A.1
- Immersion oil calculator A.1, A.2
- Immersion oil kit 3.1, 7.2, A.1
  - Purchasing from Applied Precision C.4
- Increased acquisition speed 8.15
- Info button 7.19
- Initialize the system 3.9
- InsightSSI 3.5, 8.9, 8.18, 8.29, 9.4
- InsightSSI module 8.10, 8.11, 8.13, 8.14, 8.16, 8.18, 8.20, 8.21, 8.22
- Instrument controller 8.26
- Instrument Controller and Microscope see IC/MIC
- Instrument controller icon 9.13
- Intensity distribution 7.10
- Intensity values 7.4
- Interlock jumpers F.3
- Isolation table 8.24
- Isolation transformer assembly 8.3
- J**
  - Joystick 3.6, 8.24, E.44, E.45
    - using 3.6, E.44
- K**
  - Key system components 8.1
  - Keyboard/mouse tray 8.25
  - Keylight button E.46
  - Keypad 3.6, 8.24, E.44, E.45
    - using 3.6, E.44
  - Kohler illumination 1.5, 7.5, 7.5–7.8
    - selecting 8.9
    - setup 8.50
    - with DIC 8.53
  - Kohler illumination position 7.8
- L**
  - L keys 8.28
  - Label locations F.8–F.13, F.21–??, F.21–F.32
  - Lamps off when finished check box 4.20
  - Laser action options window 4.24
  - Laser channel field 4.24
  - Laser event action 4.23, 4.24
  - Laser focus point field 4.24
  - Laser module 8.25, 8.39–8.41
  - Laser modules
    - X4 8.29
  - Laser optic module 8.8
  - Laser optics module F.10
  - Laser path splitter 8.44
  - Laser safety goggles F.6
  - Laser safety officer F.2
  - Laser safety training 2.3, F.2, F.14
  - Laser source key switch F.2
  - Lasers
    - indicator lights F.3
    - safety issues F.1–F.32
    - stand-by mode F.2
  - Legal notices. *See* Applied Precision, Inc.
  - Lens
    - ID C.7
    - setting with Resolve3D E.9
  - Lens information function A.1
  - Lens information window 3.12, 3.13
  - Lens-to-OTF matching C.8
  - Light path 3.3
  - Light path alignment 8.19, 8.28
  - Light sources 8.18–8.23

- Line requirements 8.2
- Linux
  - reference material D.9
- Linux analysis workstation 8.47
- Listing points 4.10
- Live cell
  - factory-installed filters 9.4
  - filter sets 8.38
  - filter wheel modules 9.3–9.4
- Live cell filter module 8.38
- Live cell filter set 8.29
- Live cell filter sets 8.7, D.2, D.3
- Live cell imaging 1.5, 5.1
- Live specimens
  - tracking 5.3
- LMC Reset button E.46
- Io setting E.14
- Loading a microtiter plate 7.20–7.22
- Loading a point list 4.16
- Locating a sample 7.1
- Log note action options window 4.28
- Long exposure times B.3
- Long focus range 7.28
- Low-light fluorescence 8.29

## M

- Macro commands 7.12
- Macro editor 7.11
- Macro file 7.12
- Macros 4.1
  - editing 7.11
- Maintenance
  - changing IC/MIC fuses 10.9
  - cleaning DeltaVision 10.10
  - filter wheel calibration 9.12
  - moving DeltaVision 10.10
  - system shutdown 10.3
- Mark bottom button 4.4
- Mark Point setting E.10
- Mark top button 4.4
- Marked point list icon 4.13
- Marked points list button E.13
- Marking points 4.11
  - saving a point list 4.14
- Material Safety Data Sheets (MSDS) 10.10
- Maximum extinction 8.53, 8.57, 8.59
- Maximum intensity 8.59, E.14
- Maximum iterations field 4.25
- Maximum power 8.2
- Maximum XY pixel size A.2
- Maximum Z test range 4.26
- Maximum Z test range field 7.23
- Maximum Z test range setting E.37
- Mean intensity E.14

- Mean value 7.17
- Medium button 3.7, E.45, E.47
- micrometer nut wrench 8.28
- Microscope
  - fuse for 8.66
- Microscope interface chassis 8.26, 10.2
  - replacing fuses for 10.9
- Microscopy
  - reference material D.4–D.9
- Microscopy courses 3.2
- Microtiter plate icon 7.20
- Microtiter plates
  - Aurora 7.19
- Microtiter stage 7.18–7.23, 8.29, 8.38
- Middle of sample 5.12
- Minimum current capacity 8.2
- Minimum intensity 8.53, E.14
- Minimum time interval 4.20
- Monitor 8.23
- Monitoring data acquisition 7.8
- Monitoring point visiting 4.18
- Montage view 7.35
- More settings button 7.27
- Motorized polychroic turret 3.12
- Move threshold 5.4, 5.7
- Move threshold field 4.25, 5.5
- Moving DeltaVision 10.10
- Multi-line TIRF 8.29, 8.42, 8.43
- Multiplexed wavelength 8.29, 10.9

## N

- ND arrows E.47
- ND filter, see Neutral density filter
- Network connection 8.4
- Neutral density filter 8.10, 8.11, 8.13, 8.14, 8.16, 8.18
- Number of events field 4.24
- Number of optical sections 4.8
- Number of optical sections field 4.6

## O

- OAI 8.38
- OAI See Optical Axis Integration
- Objective turret 3.11
- Objectives
  - cleaning 3.20
  - optional 8.30
- Oil calculator A.1, A.2
- Oil, immersion See Immersion oil
- Olympus FI See Olympus Fluorescence Illuminator
- Olympus Fluorescence Illumination Module F.1
- Olympus fluorescence illuminator 8.7
- Olympus IX71 Microscope 8.6
- Open experiment macro file window 7.12

- Open list button 4.15
  - Open shutter for each field 4.22
  - Operating power 8.2
  - Operating requirements 8.1
  - Optical axis integration 5.1, 5.8–5.11, 7.18, 8.38
  - Optical components 8.1, 8.6, 8.7
  - Optical filters 8.7
    - specifications D.2
  - Optical section spacing 4.7, E.18
  - Optical section spacing field 4.6
  - Optical sections 4.7
  - Optical transfer function C.1
    - conversion from PSF C.5
  - Optics
    - reference material D.10
  - Optimize list button 4.17
  - Optional components 8.1, 8.29–8.65
  - Optional filter modules 8.29
  - Optional objectives 8.30
  - Optional software 8.47
  - Options column 4.24
  - Orthogonal viewer C.5
  - OTF See Optical transfer function
  - Overlap (pixels) field 4.31
  - Overlap setting E.25
- P**
- Pan button 4.13
  - Pan tool E.12
  - Panel collection 1.4, 4.30, 4.31, E.24
  - Panel collection macros 4.30
  - Panel images 4.31
  - Panel scan pattern field 7.25
  - Panel separation 7.26
  - Pause action 4.23, 4.26
  - PCO Edge camera 8.11, 8.13
  - PCO Edge CMOS Camera 8.11
  - Personal data folder 3.17
  - Phase contrast 1.3
  - Phillips screwdriver 8.28
  - Photo sensor 8.20
  - Photo sensor cable B.3
  - Photo-bleaching 7.4
  - Photokenetic See also PK
  - Photokinetic experiments 8.44–8.46
  - Photometrics Evolve Camera 8.17
  - Photometrics Evolve Camera, see also Evolve camera
  - Photo-sensor interface 8.9
  - PID controller 8.33
  - Pixel size C.2
    - setting E.9
  - Pixel size measurement 8.28
  - PK 8.9
  - PK module 8.39
  - PK See also Photokenetic
  - Plate geometry overlay field 7.22
  - Plate scan experiment 7.23–7.32
  - Plate scan focus binning 7.28
  - Plate scan long focus range 7.29
  - Plate scan long focus range field 7.28
  - Plate scan short focus range 7.29
  - Play button 7.35
  - Point arrows E.47
  - Point list 4.10, 4.11, E.4
    - editing 4.14
    - entry positions 4.17
    - loading 4.15
    - saving 4.14
    - window 4.13
  - Point list file 4.15
  - Point list window 7.32
  - Point mark key 4.12
  - Point marking 4.11
  - Point spread function C.1
    - conversion to OTF C.5
    - file C.6
    - finding beads C.4
    - tools needed C.2
    - wavelength C.7
  - Point spread function *see also* PSF
  - Point track 4.18, 4.19
  - Point track display option 4.18
  - Point track mode 7.10
  - Point visiting 1.3, 1.4, 4.6, 4.10, 4.11
    - monitoring 4.18
    - using Resolve3D 4.15
  - Points column 4.23
  - Polarizer 8.48
  - Polychroic beam splitter F.12
  - Polychroic field 4.10
  - Polychromatic beam splitter 3.5
  - Poor illumination B.3
  - Poor image quality B.1, B.2–B.4
  - Port selector 3.3, 8.57, 8.60, 8.64
    - interlock F.2
    - knob F.3
  - Position sensor cable 9.9, 9.10, 9.11
  - Post-autofocus Z offset 4.26
  - Post-autofocus Z offset setting E.38
  - Post-event images field 8.46
  - Power cord 8.2
    - British 8.66
  - Power cords 8.2
  - Power strip bar 3.8
  - Power switches 3.8, 10.1, 10.2
  - Principal prism slider 8.51, 8.52, 8.62
  - PSF measurement 8.28
  - Pulse duration field 4.28

## Q

Quantifiable laser module 3.13  
 Quantitative processing 1.3

## R

Radial frequency C.5  
 Raster 7.25  
 Ratio graph 4.28, 7.13, 7.17  
 Ratio image action 4.24, 4.27  
 Ratio image action options window 4.27  
 Ratio image option 7.15  
 Ratio imaging 7.13  
 Recommended refractive index A.2  
 Recommended Z step A.2  
 Recommended Z step size field 4.6  
 Reference books 3.2, D.4–D.10  
 Reference channel 5.5, 5.6, 5.7  
 Reference channel field 4.26  
 Reference image 5.11–5.13  
     check box 5.12  
 Reference images E.20  
 Reference macro 7.12, 7.13  
 Reference macro window 7.13  
 Refraction, index of See Refractive Index  
 Refractive index 3.13, A.1  
     Nikon C.4  
     Olympus and Zeiss C.4  
 Refresh exposure conditions 4.10  
 Refresh exposure conditions button E.20  
 Registered trademarks. See Applied Precision, Inc.  
 Remove Trail button E.46  
 Repeatable slide holder 4.11, 7.1–7.3, 8.26, 8.27  
 Replace field 7.12  
 Replace point button 4.14  
 Replacing IC/MIC fuses 10.9  
 Requirements  
     altitude 8.4  
     country-specific 8.3  
     electrical 8.1, 8.2  
     environmental 8.1, 8.3  
     facility 8.1  
     humidity 8.4  
     line 8.2  
     operating 8.1  
     power cord 8.2  
     space 8.3  
     temperature 8.4  
 Reset button E.46  
 Resolution ratio A.2  
 Resolve3D  
     %T setting E.8  
     Acquire image E.3  
     Autofocus options E.37

Aux mag setting E.9  
 Bin setting E.9  
 calibrate images E.9  
 Calibration menu E.5  
 clear stage thumbnails E.4  
 clear stage trails E.4  
 command line interface E.4  
 Continuous acquire E.3  
 Design/Run Experiment window E.15  
 enable fast acquisition E.17  
 excitation setting E.8  
 experiment E.3  
 exposure setting E.8  
 exposure time 7.4  
 find exposure E.9  
 Help menu E.6  
 image control fields E.7  
 Image size setting E.9  
 Info setting E.9  
 Lens setting E.9  
 menus E.2  
 Options menu E.4  
 Panels tab E.24  
 Pixel size setting E.9  
 point list E.4  
 scratch file E.3  
 Sectioning tab E.17  
 selecting cameras 9.1–9.3  
 Settings window E.30  
 shortcuts E.14  
 Snapshot E.3  
 toolbar E.6  
     window 3.10, E.1  
 Resolve3D snapshot window 3.19  
 Restore TIRF Depth button 8.44  
 Reviewing large areas 4.30  
 ROI percent 5.8  
 ROI percent slider 4.26  
 Run tab 4.1  
 Running experiments 4.1

## S

Safety 2.1  
     bright light exposure 2.3  
     danger of shock 2.3  
     using proper filters 2.3  
     warning labels 2.2  
 Safety labeling F.6–F.13, F.19–F.32  
 Sample preparation  
     papers 3.2  
 Sample thickness setting E.18  
 Sampling wells 8.38  
 Saturation 7.4, 7.5, B.4  
 Save Image button E.47

- Save list button 4.14
  - Saving image data 3.17
  - Scale settings E.14
  - Scale values E.14
  - Scaletter, Beth 1.2
  - Scratch mode 7.10
  - Search field 7.12
  - Sectioning specimens 4.3
  - Sectioning tab E.17
  - Serpentine 7.25
  - Settings window E.30
    - action buttons E.43
    - Autofocus tab E.37
    - Display tab E.30
    - Misc tab E.42
  - Short focus range 7.29
  - Show stage trails option 3.17
  - Shut down the system 10.1–10.3
  - Shutting down DeltaVision 10.3
  - Significant drift 7.19
  - Slide holder 8.26, 8.27
    - adapter 8.27
  - Slow button 3.7, E.45, E.47
  - Snapshot E.3
  - Snapshot window 3.19
  - softWork
    - for Linux 8.28
  - softWoRx 1.1, 8.28
    - DMS 8.47
    - Explorer 8.47
    - explorer 8.30
    - main menu 3.10
    - suite 8.30
    - Suite for Windows 8.47
  - softWoRx Explorer 8.47
  - softWoRx Suite 8.47
  - softWoRx Workstation 8.26
    - Troubleshooting B.2
  - Solid state illumination 8.9, 8.29
  - Spare camera tray 9.2
  - Specimen refractive index A.2
  - Spherical aberration A.1
  - Spherical aberration, minimizing C.4
  - Spiral mosaic E.12, E.42
  - Stage
    - safety label location F.12
  - Stage controls E.10
  - Stage trails 3.15
  - Stage Z control bar 3.16
  - Standard components 8.1
  - Standard filename extensions D.1
  - Standard filter sets 8.7
  - Standard microscope slide 7.2
  - Stand-by mode F.2
  - Start Coordinates setting E.25
  - Start scan button 7.16
  - Starting the system 10.3
  - Step Decrease/Increase buttons E.47
  - Stitching images 4.30
  - Stop icon 7.34
  - Symmetric flare C.5
- ## T
- T handle hex key 8.28
  - Technical support 8.4
  - Temperature controller 8.31, 8.32
  - Temperature probe 8.35
  - Temperature requirements 8.4
  - Temperature variation 8.4
  - Tension adjustment 3.4
  - Theoretical OTF See Optical transfer function
  - Time course specification 8.46
  - Time point field 4.20
  - Time points column 4.23
  - Time-lapse 1.3, 1.4
    - check box 4.19
    - setting up experiments 4.19
    - tab 4.19
    - using the Actions tab 4.20
  - Time-lapse action options window 4.27
  - Time-lapse image data 7.15
  - TIRF 8.9, 8.29
    - angle adjustments 8.44
    - concepts 8.41–8.42
    - multi-line 8.42
    - multiline 8.43
    - safety considerations F.6
  - TIRF/PK module 8.9, 8.39
  - Tool kit 8.28
  - Toolbar
    - Resolve3D E.6
  - Top of sample 4.6, 5.12
  - Total time field 4.20
  - Tracking cells 5.3
  - Tracking method field 4.26
  - Tracking methods 5.6
  - Trademarks. See Applied Precision, Inc.
  - Trans Shutter button E.48
  - Transfer speed setting E.34
  - Transmitted light 8.18, 8.22, 8.23
  - Transmitted light field stop aperture 8.52, 8.53
  - Transmitted light source button 3.7, E.45
  - Trigger TTL action 4.24, 4.28
  - Troubleshooting
    - controller B.1
    - encoder error B.2
    - image quality 9.12, B.2
    - light transmittance 9.12

- softWoRx Workstation B.2
- workstation B.2
- TTL action options window 4.28
- TTL channel field 4.28
- TTL triggers
  - to external devices 4.29
- Turning off the system 3.19, 3.21

## U

- UltimateFocus 7.23, 8.9
  - action options window 4.25
- UltimateFocus action 4.23
- UltimateFocus module 8.30, 8.46
- Ultraviolet light 2.3
- Undo icon 7.29
- Uniform time intervals 8.46
- Use channel 1 as numerator check box 4.27
- Use conventional time-lapse check box 4.22
- Use item button 7.12
- Use photosensor setting E.35
- User interface conventions 0.iii
- User interlock connector F.3, F.4
- User interlock port F.3

## V

- Vibration isolation table 8.24
- Video display 8.23
- Viewing image previews 7.8
- Visit bottom setting E.11
- Visit middle setting E.11
- Visit point button 4.15
- Visit point list field 4.17
- Visit points list check box 4.17
- Visit Top setting E.11
- Visited points column 4.23
- Visiting points See Point visiting
- Voxels 4.30, C.7

## W

- Wait action 4.23, 4.27
- Wait action options window 4.27
- Warning labels 2.2
- Wavelength then Z 4.21
- When column 4.24
- Workstation 8.25, 8.26, 8.47
- Wrench set 8.28

## X

- X and Y arrow keys E.47
- X step size setting E.13
- X4 laser module 8.9, 8.29, 8.39–8.41
  - safety F.1–F.32
- Xenon arc lamp 8.18, 8.19

- Xenon bulb replacement 10.3–10.9
- Xenon light source
  - and bulb replacement 10.3

## Y

- Y step size setting E.13

## Z

- Z arrow keys E.47
- Z focus 3.4
- Z sectioning 4.3, 4.8
- Z Sectioning check box 7.14
- Z slider E.13
- Z stack 7.18
- Z step size 4.7, 4.8
- Z step size setting E.13
- Z sweep acquisition 5.1, 5.8–5.11
- Z then wavelength 4.22
- Z1/Z2 Mark buttons E.48
- Zoom tool E.13
- Zoom wheel 3.16, 4.13

For local office contact information, visit:

[www.gelifesciences.com/contact](http://www.gelifesciences.com/contact)

GE Healthcare UK Limited  
Amersham Place, Little Chalfont  
Buckinghamshire, HP7 9NA  
UK

[www.gelifesciences.com](http://www.gelifesciences.com)



imagination at work

GE, imagination at work, and GE monogram are trademarks of General Electric Company.

Applied Precision, DeltaVision, DeltaVision OMX, softWoRx, UltimateFocus, and Blaze are trademarks of GE Healthcare companies.

Photometrics is a registered trademark and Evolve is a trademark of Roper Scientific, Inc.

Stradus is a trademark of Vortran Laser Technology, Inc.

All other third party names and trademarks referred to in this document are the property of their respective owners.

Any use of this software is subject to GE Healthcare Standard Software End-User License Agreement for Life Sciences Software Products. A copy of this Standard Software End-User License is available on request.

© 2014 General Electric Company – All rights reserved. First published April 2013.

All goods and services are sold subject to the terms and conditions of sale of the company within GE Healthcare which supplies them. A copy of these terms and conditions is available on request. Contact your local GE Healthcare representative for the most current information.

**Notice to purchaser**

DeltaVision OMX Imaging Systems are for research use only – not for use in diagnostic procedures.

GE Healthcare Bio-Sciences AB  
Björkgatan 30  
751 84 Uppsala  
Sweden

GE Healthcare Europe, GmbH  
Munzinger Strasse 5  
D-79111 Freiburg  
Germany

GE Healthcare Bio-Sciences Corporation  
800 Centennial Avenue, P.O. Box 1327  
Piscataway, NJ 08855-1327

GE Healthcare Japan Corporation  
Sanken Bldg., 3-25-1, Hyakunincho  
Shinjuku-ku, Tokyo 169-0073  
Japan